

MULTI 1 ONE

PRODUCTS HANDBOOK





GLOSSARY

Tipping load, max.	It's the load, lifted just off the ground, that will cause to achieve the tipping limit condition. Machine is straight, with rear weights, on firm, level ground and boom not extended. Weight of attachment included, the tipping load is the value indicated minus the weight of the attachment. Load is distributed evenly on pallet forks, with the load centre of gravity at 500 mm from the vertical part of pallet fork arms.
Lifting capacity straight, max.	It's the maximum load that can be lifted just off the ground when the machine is straight on firm level ground, with rear weights and boom not extended. Weight of attachment included, the net lifting load is the value indicated minus the weight of the attachment. Load is distributed evenly on pallet forks, with the load centre of gravity at 500 mm from the vertical part of pallet fork arms.
Max. lift height	It's the height of the coupling plate pivot point with extended boom.
Breakout force / 50 cm	Rollback force measured at 500 mm from the pivot point, max value.
Pushing force	Calculated (c) pushing force of the machine with 100% efficiency and with smallest wheels available.
Drive speed (max.)	Maximum speed that can be achieved with the largest diameter tires available, on a flat surface and machine without attachments.
NA	Item not available.

Note:

- Never exceed the rated lifting or hydraulic capacity of the machine.
- When using attachments, know their capacity ratings and machine limitations. Machine specifications can be found in the Operator's Manual.
- If not specified, all dimensions have been taken with standard tires.
- All products listed in this catalogue may not be available on all markets and countries. Please consult your local MultiOne dealer for availability.
- Compatibility table between attachments and loader models are advisory. Please consult your local MultiOne dealer to make sure that the attachment is compatible with your MultiOne mini loader.



TABLE OF CONTENTS





LOADERS	4	HYDRAULIC BREAKER.....	88
1 SERIES: 1.1.....	4	DOZER BLADE.....	89
2 SERIES: 2.3 EFI	6	TRENCHER	90
5 SERIES: 5.2 K	10	MINI DIGGER.....	91
5 SERIES: 5.3 K	12	SCREENING BUCKET.....	92
6 SERIES: 6.3 iDS	16	RADIO CONTROLLED BACKHOE	93
7 SERIES: 7.2 K	20	AUGER.....	94
8 SERIES: 8.4S K	24	OPTIONS FOR AUGER.....	95
8 SERIES: 8.5S K	26	GRADER.....	96
11 SERIES: 11.6 K.....	30	CEMENT MIXER.....	97
11 SERIES: 11.9 K.....	32	CONCRETE MIXING BUCKET	98
EZ SERIES: EZ5.....	36	COLD PLANER.....	99
EZ SERIES: EZ5 LONG RANGE	38	PIPE LAYER RIPPER	100
EZ SERIES: EZ7.....	42	ESTATE & PROPERTY MAINTENANCE.....	101
EZ SERIES: EZ8.....	44	SWEEPER WITH COLLECTOR BOX	101
EZ SERIES: EZ8 LONG RANGE	46	LEAF VACUUM.....	102
WHEELS.....	51	WEED BRUSH.....	103
OPTIONS.....	52	DEBRIS AND LEAF BLOWER	104
BUCKETS, MATERIAL HANDLING	60	SOLAR PANEL WASHER	105
GENERAL BUCKET.....	60	ROTARY SWEEPER.....	106
NEW GENERAL BUCKET.....	61	SNOW BLADE	107
LEVELLING BUCKET	62	SNOW PLOW	108
COMBO BUCKET	63	SNOW BLOWER	109
GRAPPLE BUCKET.....	64	SALT AND SAND SPREADER.....	110
DEMOLITION GRAPPLE BUCKET	65	DROP SPREADER	111
NEW LIGHT MATERIAL BUCKET.....	66	TRAILER.....	112
HIGH TIP BUCKET	67	HIGH PRESSURE WASHER	113
PALLET FORK	68	STAKE INSTALLER	114
PALLET FORK HYDRAULIC CLAMP.....	69	AERIAL WORK PLATFORM	115
BIG BAG LIFTER.....	70	STREET WASHER.....	116
JIB CRANE, ONE-PIECE OR TELESCOPIC	71	GROUNDS CARE.....	117
LIFTING TROLLEY	72	FLAIL MOWER WITH SIDE SHIFT	117
PALLET FORK WITH SIDE SHIFT.....	73	FLAIL MOWER	118
JOB SITE TOOLBOX.....	74	HEAVY DUTY FLAIL MOWER	119
FARMING	75	SIDE BOOM WITH FLAIL MOWER DZ2	120
HEAVY DUTY SILAGE FORK.....	75	TORNADO LAWN MOWER	121
MANURE FORK.....	76	LAWN MOWER.....	122
HAY BALE GRAPPLE	77	SPIKE AERATOR.....	123
BALE HANDLER.....	78	CORE AERATOR.....	124
SQUARE BALE CLAMP.....	79	HEDGE CUTTER.....	125
BALE FORK.....	80	SICKLE BAR MOWER	126
HIVE HANDLER.....	81	LANDSCAPE POT CLAMP	127
HORSE ARENA HARROW	82	TELESCOPIC SIDE ARM M1-15.....	128
HORSE STABLE PACKER.....	83	ARTICULATED SIDE ARM M1-30.....	129
FEED DISPENSER.....	84	SPRAYER	130
SCREW FEED PUSHER.....	85	VINEYARD AND ORCHARD	131
RUBBER SCRAPER.....	86	STRING SHOOT REMOVER	131
PUSH BROOM.....	87	DUAL BLADE HEDGE TRIMMER	132
DIGGING & CONSTRUCTION	88	INTER-ROW MOWER	133
		TREE SHAKER WITH COLLECTOR	134

TABLE OF CONTENTS

VINEYARD SPRAYER	135
VINEYARD TOOL CARRIER.....	136
LANDSCAPING.....	137
LEVELLER.....	137
ROLLER.....	138
RIPPER	139
ROTARY TILLER	140
POWER HARROW	141
POWER RAKE.....	142
STONE BURIER	143
POWER PLOW.....	144
POWER AUGER FOR TREE PLANTING.....	145
SWING STUMP GRINDER	146
STUMP GRINDER	147
FORESTRY.....	148
FORESTRY MULCHER	148
BRANCH CUTTER.....	149
TIMBER GRAB	150
WINCH.....	151
TREE SHEAR	152
LOG GRAPPLE.....	153
INDUSTRIAL LOG GRAPPLE.....	154
LOG SPLITTER	155
DUMPER	156
HYDRAULIC BIO SHREDDER.....	157
OTHER ATTACHMENTS	158
ALUMINIUM RAMPS	158
OPTIONS FOR ATTACHMENTS	159
SIDE SHIFT ADAPTER.....	159
TILT ADAPTER	160
ATTACHMENT ROTATOR.....	161
MULTI CONNECTOR ADAPTOR FOR MACHINES	162
ATTACHMENT COUPLING PLATE	162
SKID-STEER ATTACHMENT ADAPTER PLATE.....	162

1 SERIES: 1.1

<http://tiny.cc/multione1-1EN>

 MAX LIFTING CAPACITY 250 kg	 ENGINE POWER 12 hp	 SPEED 8 km/h	 FLOW RATE 19 l/min	 LIFT HEIGHT 1,8 m
---	--	--	--	---



Model	1.1
Engine	Yanmar L100 - 1 cylinder - 435cc
Emission Standards	Stage V and Tier 4 Final
Power (Iso Gross) / Torque	12 HP / 21 Nm @ 3000 rpm
Fuel	Diesel
Transmission	Hydrostatic
Drive speed (max.)	8 km/h (5 mph)
Aux. hydraulics oil flow	19 l/min (5 GPM)
Max. lifting height	1,8 m (70.9 in)
Tipping load, max. ⁽¹⁾	320 kg (705 lbs)
Lifting capacity, max. ⁽²⁾	250 kg (551 lbs)
Breakout force / 50 cm (19.7 in)	250 kg (551 lbs)
Pushing force (c)	500 kgf (500 kp)
Average ground pressure (w/standard tires)	298 kg/m ² (61 lbs/sqft)
Turning radius: inside/outside	0/993 mm (0/39 in)
Standard tires (Tractor profile)	18x9.50-8
Weight	398 kg (880 lbs)
Product Code	C926006

⁽¹⁾ Tipping limit with rear weights and boom lifted just off the ground. Weight of attachment included.⁽²⁾ Maximum load that can be lifted just off the ground. Weight of attachment is included.

Note: Refer to the Operator's manual for the comprehensive load diagram.

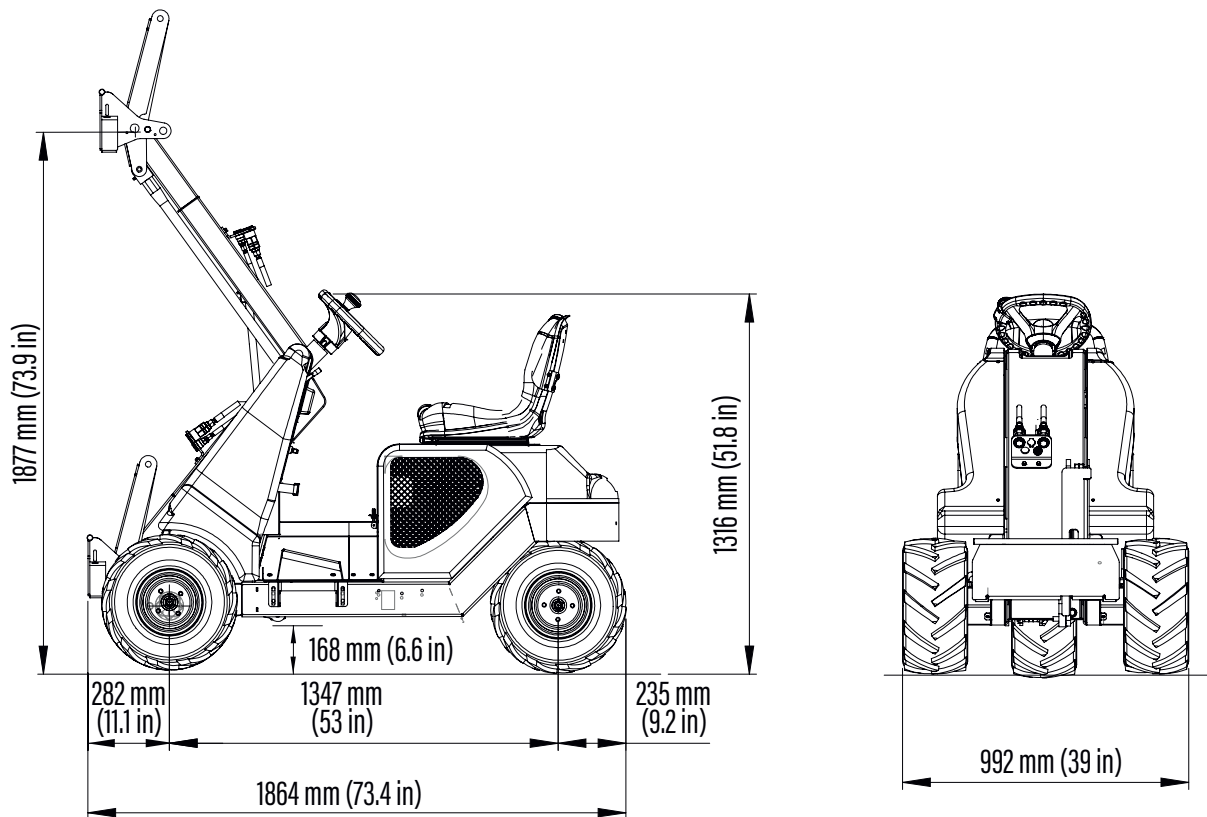

FEATURES

- YANMAR L100 engine, 1 cylinder, diesel engine, 435 cc, air cooled with electric start
- Stage V and Tier 4 Final compliant engine
- 3WD hydrostatic transmission with differential lock
- Variable displacement drive pump
- 3 line hydraulic outlets
- Boom with self-levelling
- 4-functions joystick
- Ergonomic seat with adjustable position
- Mechanical parking brake

Options	CODE
Gps tracker	C883075
Turf tires 18x9.50-8, set of 3	C885023

2 SERIES: 2.3 EFI

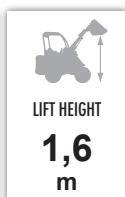
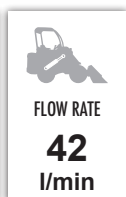
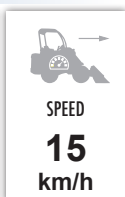
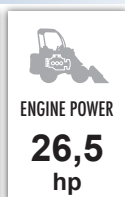
<http://tiny.cc/multione2-EN>

EFI
**ELECTRONIC
FUEL
INJECTION**

Model	2.3 EFI
Engine	Kohler EFI ECV749 - 2 cyl. - 747 cc
Emission Standard	Stage V and EPA/CARB Phase III
Power (Iso Gross) / Torque	26,5 HP / 55,5 Nm @ 2600 rpm
Fuel	Petrol
Transmission	Hydrostatic
Drive speed (max.) ⁽¹⁾	15 km/h (9.3 mph)
Aux. hydraulics oil flow	42 l/min (11.1 GPM)
Max. lifting height	1,6 m (63 in)
Tipping load, max. ⁽²⁾	700 kg (1543 lbs)
Lifting capacity straight, max. ⁽³⁾	560 kg (1235 lbs)
Breakout force / 50 cm (19.7 in)	840 kg (1852 lbs)
Pushing force (c)	770 kgf (770 kp)
Average ground pressure (w/standard tires)	583 kg/m ² (119 lbs/sqft)
Turning radius: inside/outside	700/1698 mm (27.6/66.9 in)
Standard tires (Tractor profile)	20x8.00-10
Weight	710 kg (1570 lbs)
Product Code (Standard)	C951028
2.3 EFI Pack 1 (w/fully enclosed cab with heating system)	C951029

⁽¹⁾ Maximum speed that can be achieved with the largest diameter tires available, on a flat surface and machine without attachments.

⁽²⁾ Tipping limit, when the machine is straight, with rear weights and boom lifted just off the ground. Weight of attachment included.

⁽³⁾ Maximum load that can be lifted just off the ground when the machine is straight and with rear weights. Weight of attachment is included.

Note: Refer to the Operator's manual for the comprehensive load diagram.

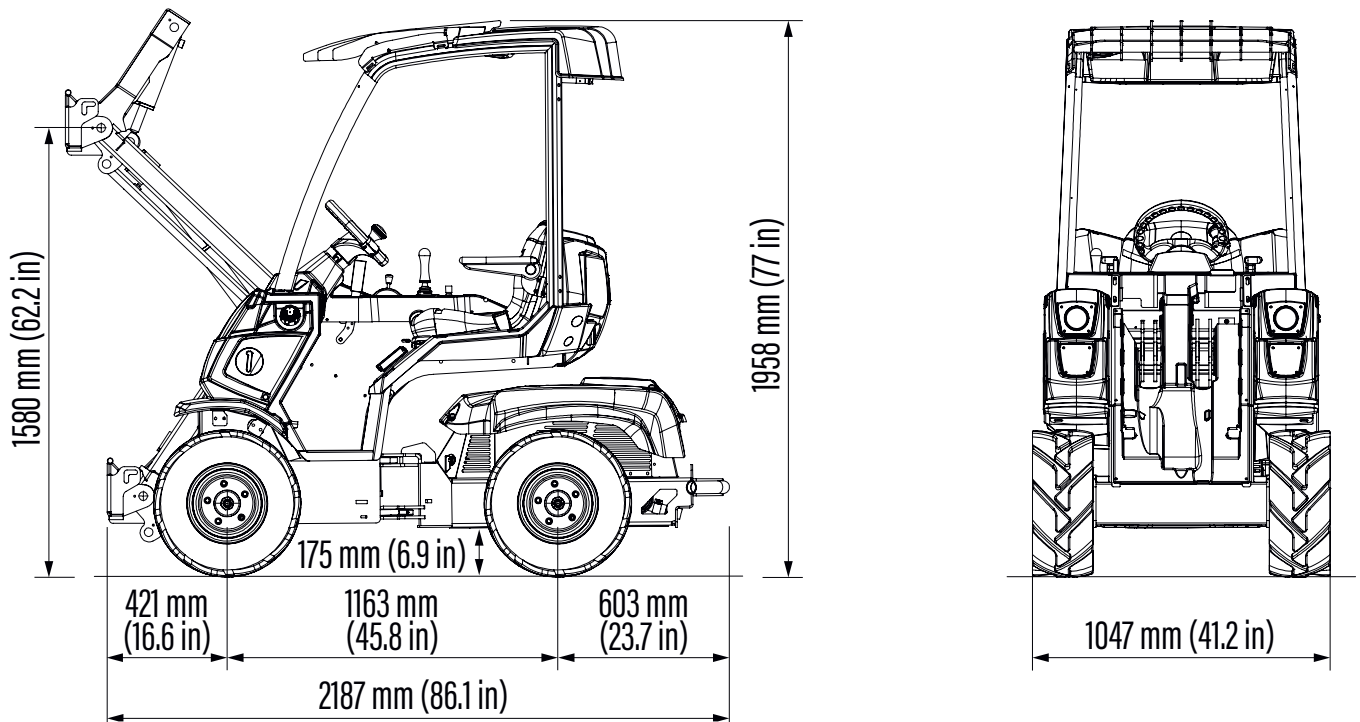

Tires size	Height	Width
20x8.00-10	1958 mm (77 in)	1047 mm (41.2 in)
23x8.50-12	1996 mm (78.6 in)	1060 mm (41.7 in)

FEATURES

- Kohler Command Pro EFI ECV749, 2 cylinder, 747 cc. petrol engine, air cooled, electric start, with electronic fuel injection (EFI)
- Stage V and EPA/CARB Phase III compliant engine
- DBS (Dynamic Block System)
- Hydraulic oil cooler
- Self-levelling H-frame boom
- Hydraulic multiconnector
- 4-functions joystick
- Hour meter, fuel gauge, engine MIL
- 4WD hydrostatic Direct Drive motors, proportional servo control
- Hydraulically pilot operated variable displacement drive pump
- ROPS-FOPS Level I
- 2 front working lights
- Ergonomic fully adjustable suspension heated seat with armrests and seat belt
- Mechanical parking brake
- High efficiency wheel motors

2 SERIES - OPTIONS

Options	Code
3 additional working halogen lights	C883064
3 additional working LED lights	C883018
Backup warning beeper	C883021
Beacon light	C883039
Driver area cover	C880049
Flat face coupling kit	C880221
Fully enclosed cab with heating system	C885224
GPS tracker	C883075
Kohler Bluetooth diagnostic interface kit (compatible with Android or iOS diagnostic applications)	C883201
Left protection bar for operator	C885027
Mirrors	C880081
Polycarbonate back window (smart cabin)	C885239
Polycarbonate right side (smart cabin)	C885238
Polycarbonate windscreen (smart cabin)	C885237
Rear weights 180 kg (90 kg + 90 kg) / 396 lbs (198lbs + 198 lbs)	C880054
Snow chains for wheels 20x8.00-10, set of 2	C880040
Tie down bracket on wheel hub, set of 4	C883068
Torque divider	C883600
Tractor tires 23x8.50-12, set of 4	C884005
Trailer coupling	C885014
Turf profile tires 20x8.00-10, set of 4	C885211
Turf tires 23x8.50-12, set of 4	C884006
Warning & Safety lights for road travel (with mirrors)	C885240
Wheel spacer 10 mm (0,4 in), set of 4 (max. 2 pcs for wheel)	C880090
Wheel spacer 55 mm (2,2 in), set of 4 (max. 1 pcs for wheel)	C885010
ACI Upgrade	C090027

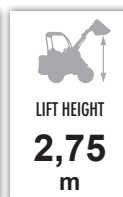
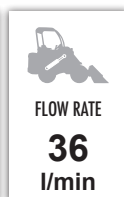
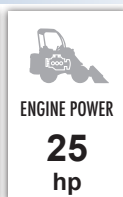

5 SERIES: 5.2 K

<http://tiny.cc/5series-EN>

Model	5.2 K
Engine	Kubota D902 - 3 cyl. - 898 cc.
Emission Standard	Stage V
Power (Iso Gross) / Torque	25 HP / 55 Nm @ 2400 rpm
Fuel	Diesel
Transmission	Hydrostatic
Drive speed (max.) ⁽¹⁾	14 km/h (8.7 mph)
Aux. hydraulics oil flow	36 l/min (9.5 GPM)
Max. lifting height	2,75 m (108 in)
Tipping load, max. ⁽²⁾	1110 kg (2447 lbs)
Lifting capacity straight, max. ⁽³⁾	890 kg (1962 lbs)
Breakout force / 50 cm (19.7 in)	800 kg (1764 lbs)
Pushing force (c)	900 kgf (900 kp)
Average ground pressure (w/standard tires)	905 kg/m ² (185 lbs/sqft)
Turning radius: inside/outside	890/1890 mm (35/74.4 in)
Standard tires (Tractor profile)	23x8.50-12
Weight	1020 kg (2250 lbs)
Product Code	C977017

⁽¹⁾ Maximum speed that can be achieved with the largest diameter tires available, on a flat surface and machine without attachments.

⁽²⁾ Tipping limit, when the machine is straight, with rear weights and boom lifted just off the ground. Weight of attachment included.

⁽³⁾ Maximum load that can be lifted just off the ground when the machine is straight and with rear weights. Weight of attachment is included.

Note: Refer to the Operator's manual for the comprehensive load diagram.

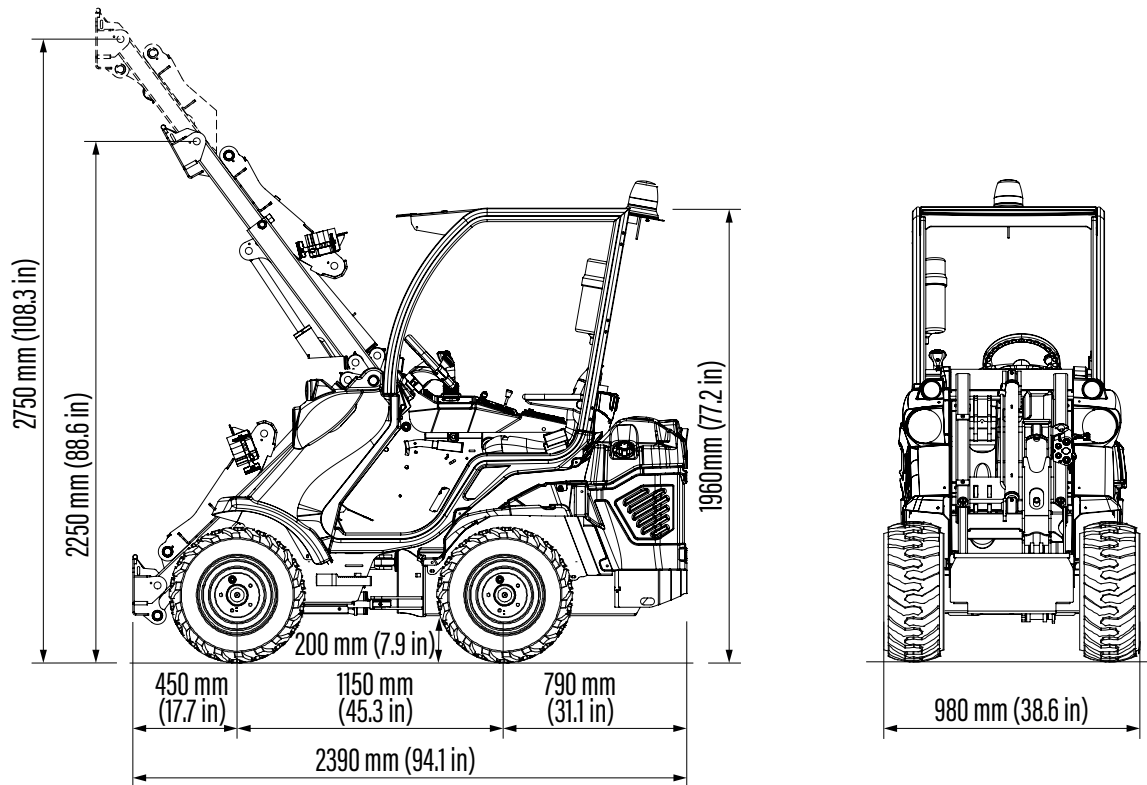

Tires size	Height	Width
23x8.50-12	1960 mm (77.2 in)	980 mm (38.6 in)
23x10.50-12 ET-25	1960 mm (77.2 in)	1090 mm (42.9 in)
27x8.50-15	2010 mm (79.1 in)	1000 mm (39.4 in)
26x12.00-12 ET-50	1998 mm (78.6 in)	1200 mm (47.2 in)

FEATURES

- Kubota D902, 3 cyl. - 898 cc diesel engine, water cooled, electric start, glow plug
- Stage V compliant engine
- Unbreakable Body Panels
- Hydraulic oil cooler
- Hydraulically pilot operated variable displacement drive pump
- Hydraulic multiconnector
- Double-H telescopic boom with self-levelling
- 4-functions joystick
- ROPS-FOPS Level I
- LCD graphic display with programmed service
- 4WD hydrostatic Direct Drive motors, proportional servo control
- 2 front working lights
- Ergonomic fully adjustable suspension heated seat with armrests and seat belt
- Mechanical parking brake
- High efficiency wheel motors
- Dynamic Block System (DBS)

5 SERIES: 5.3 K

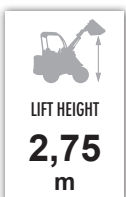
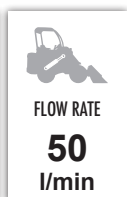
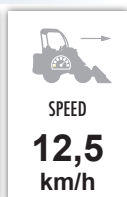
<http://tiny.cc/5series-EN>

ACI
ATTACHMENT
CONTROL
INTERFACE



Model	5.3 K
Engine	Kubota D1305, 3 cyl. - 1261 cc.
Emission Standard	Stage V
Power (Iso Gross) / Torque	25 HP / 85 Nm @ 1700 rpm
Fuel	Diesel
Transmission	Hydrostatic
Drive speed (max.) ⁽¹⁾	12,5 km/h (7.8 mph)
Aux. hydraulics oil flow	50 l/min (13.2 GPM)
Max. lifting height	2,75 m (108 in)
Tipping load, max. ⁽²⁾	1290 kg (2844 lbs)
Lifting capacity straight, max. ⁽³⁾	1030 kg (2270 lbs)
Breakout force / 50 cm (19.7 in)	800 kg (1764 lbs)
Pushing force (c)	900 kgf (900 kp)
Average ground pressure (w/standard tires)	854 kg/m ² (175 lbs/sqft)
Turning radius: inside/outside	800/2000 mm (31.5/78.7 in)
Standard tires (Tractor profile)	23x10.50-12 ET-25
Weight	1070 kg (2360 lbs)
Product Code	C977038

⁽¹⁾ Maximum speed that can be achieved with the largest diameter tires available, on a flat surface and machine without attachments.

⁽²⁾ Tipping limit, when the machine is straight, with rear weights and boom lifted just off the ground. Weight of attachment included.

⁽³⁾ Maximum load that can be lifted just off the ground when the machine is straight and with rear weights. Weight of attachment is included.

Note: Refer to the Operator's manual for the comprehensive load diagram.

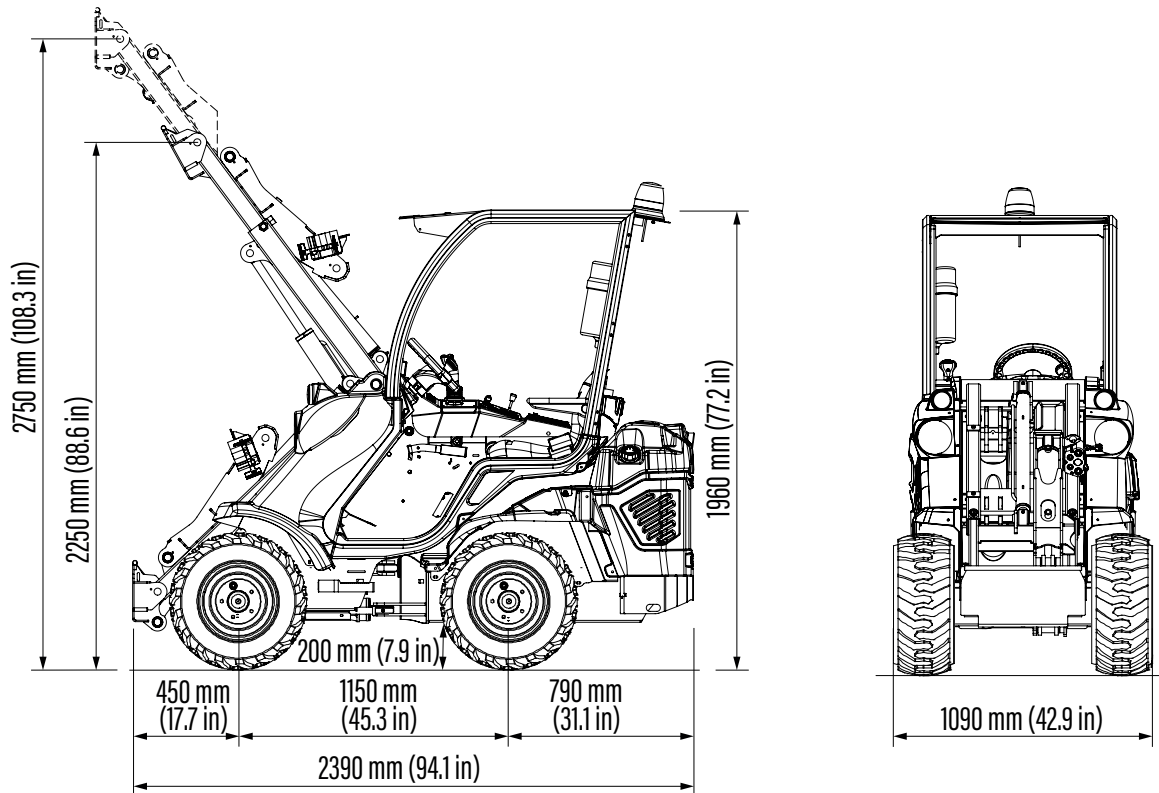

Tires size	Height	Width
23x8.50-12	1960 mm (77.2 in)	980 mm (38.6 in)
23x10.50-12 ET-25	1960 mm (77.2 in)	1090 mm (42.9 in)
27x8.50-15	2010 mm (79.1 in)	1000 mm (39.4 in)
26x12.00-12 ET-50	1998 mm (78.6 in)	1200 mm (47.2 in)

FEATURES

- Kubota D1305, 3 cyl. -1261 cc, diesel engine water cooled, electric start, glow plug
- Stage V compliant engine
- Hi-Flow system
- ACI with Multifunction joystick (22 functions)
- Unbreakable Body Panels
- Self-levelling double-H telescopic boom
- Hydraulically pilot operated variable displacement drive pump
- Dynamic Block System (DBS)
- Hydraulic oil cooler
- Hydraulic multiconnector
- ROPS-FOPS Level I
- LCD graphic display with programmed service
- 4WD hydrostatic Direct Drive motors, proportional servo control
- 2 front working lights
- Ergonomic fully adjustable suspension heated seat with armrests and seat belt
- Mechanical parking brake
- High efficiency wheel motors

5 SERIES - OPTIONS

Options	Code
110 V engine block heater	C885255
220 V engine block heater	C885250
2" Hitch receiver (not compatible with C883047)	C883062
3 additional working halogen lights	C883064
3 additional working LED lights	C883018
Additional front hydraulic outlets (5.3 K only)	C883503
Attachment coupling plate for rear mounting (not compatible with C883047)	C880031
Automatic locking plate	C880016
Backup warning beeper	C883021
Beacon light	C883039
Driver area cover	C880049
Flat face coupling kit	C880221
Floating boom valve	C885223
Fully enclosed cab with sound insulation linen	C883510
GPS tracker	C883075
Heating system	C883073
Left protection bar for operator	C885026
Mirrors	C880081
Multifunction joystick with ACI (5.2 K only)	C883080
Polycarbonate back window (smart cabin)	C883508
Polycarbonate right side (smart cabin)	C883507
Polycarbonate windscreen (smart cabin)	C883506
Rear 12V electric socket	C883022
Rear bull bar (not compatible with C883062, C885014 and C880031)	C883047
Rear hydraulic outlets - double	C883502
Rear hydraulic outlets - single	C883501
Rear side weights 80 kg (40 kg + 40 kg) / 176 lbs (88 lbs + 88 lbs)	C883076
Rear weights 180 kg (90 kg + 90 kg) / 396 lbs (198lbs + 198 lbs)	C880054
Skid tires 27x8.50-15, set of 4	C884011

5 SERIES - OPTIONS

Options	Code
Snow chains for wheels 23x10.50-12, set of 2	C880046
Snow chains for wheels 23x8.50-12, set of 2	C880041
Snow chains for wheels 26x12.00-12, set of 2	C880042
Tie down bracket on wheel hub, set of 4	C883068
Torque divider	C883600
Tractor tires 23x10.50-12 ET-25, set of 4	C884007
Tractor tires 23x8.50-12, set of 4	C884005
Tractor tires 26x12.00-12 ET-50, set of 4	C884009
Trailer coupling (not compatible with C883047)	C885014
Turf tires 23x10.50-12 ET-25, set of 4	C884008
Turf tires 23x8.50-12, set of 4	C884006
Turf tires 26x12.00-12 ET-50, set of 4	C884010
Warning & Safety lights for road travel with mirrors	C883511
Wheel spacer 10 mm (0.4 in), set of 4 (max. 2 pcs for wheel)	C880090
Wheel spacer 55 mm (2.2 in), set of 4 (max. 1 pcs for wheel)	C885010
ACI Upgrade (5.2 K only)	C090027
EU Certificate of Conformity (CoC) for road approval	COC

6 SERIES: 6.3 iDS

<http://tiny.cc/6seriesEN>



MAX LIFTING
CAPACITY
1120
kg



ENGINE POWER
25
hp



SPEED
23
km/h



FLOW RATE
60
l/min



LIFT HEIGHT
2,92
m

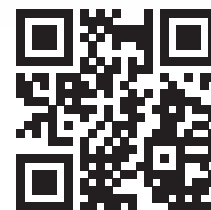

ACI
ATTACHMENT
CONTROL
INTERFACE



NEW

Model	6.3 iDS
Engine	Rehiko / Kohler KSD 1403 NA, 3 cyl. - 1391 cc.
Emission Standard	Stage V and Tier 4 Final
Power (Iso Gross) / Torque	25 HP / 90 Nm @ 1800 rpm
Fuel	Diesel
Transmission	Hydrostatic
Drive speed (max.) ⁽¹⁾	11,5 - 23 km/h (7 - 14 mph)
Aux. hydraulics oil flow	60 l/min (15.8 GPM)
Max. lifting height	2,92 m (115 in)
Tipping load, max. ⁽²⁾	1400 kg (3086 lbs)
Lifting capacity straight, max. ⁽³⁾	1120 kg (2469 lbs)
Breakout force / 50 cm	1400 kg (3086 lbs)
Pushing force (c)	2050 kgf (2050 kp)
Average ground pressure (w/standard tires)	1073 kg/m ² (219 lbs/sqft)
Turning radius: inside/outside	905/2020 mm (35.6/79.5 in)
Standard tires (Tractor profile)	23X8.50-12
Weight	1470 kg (3240 lbs)
Product Code	C961035

⁽¹⁾ Maximum speed that can be achieved with the largest diameter tires available, on a flat surface and machine without attachments.

⁽²⁾ Tipping limit, when the machine is straight, with rear weights and boom lifted just off the ground. Weight of attachment included.

⁽³⁾ Maximum load that can be lifted just off the ground when the machine is straight and with rear weights. Weight of attachment is included.

Note: Refer to the Operator's manual for the comprehensive load diagram.

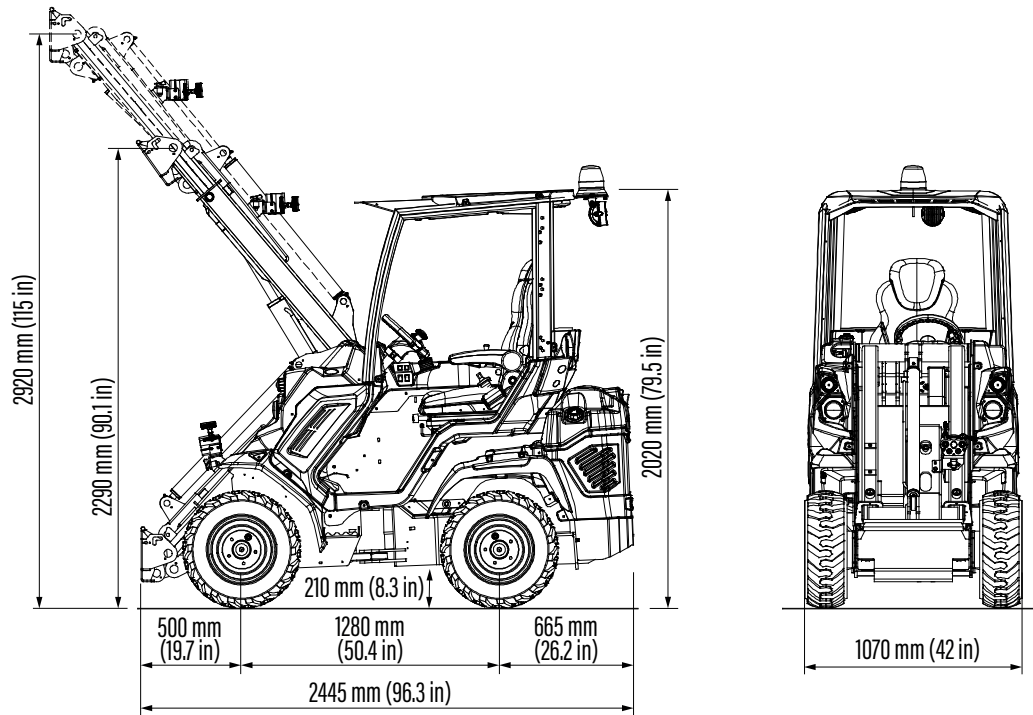

Tires size	Height	Width
23X8.50-12	2020 mm (79.5 in)	1070 mm (42 in)
23X10.50-12 ET-25	2020 mm (79.5 in)	1130 mm (44.5 in)
26X12.00-12 ET-50	2040 mm (80.3 in)	1280 mm (50.4 in)
27X8.50-15	2080 mm (81.9 in)	1070 mm (42 in)
27X10.50-15	2080 mm (81.9 in)	1150 mm (45.3 in)

FEATURES

- Rehlko/Kohler KSD 1403 NA, 3 cyl. -1391 cc, diesel engine water cooled, electronic injection system, electric start, glow plug
- Stage V and Tier 4 Final compliant engine
- Unbreakable Body Panels
- Hi-Flow system
- DBS (Dynamic Block System)
- ACI with Multifunction joystick (22 functions)
- Hydraulically pilot operated variable displacement drive pump
- Self-levelling double-H telescopic boom
- 2 Speed
- ETC - Electronic Throttle Control
- Self-locking multi-disk parking brake
- Hydraulic oil cooler
- Hydraulic multiconnector
- Radial Piston high efficiency and heavy duty wheel motors
- 4WD hydrostatic Direct Drive motors, proportional servo control
- ROPS-FOPS Level I
- LCD graphic display with programmed service
- 2 front working lights
- Ergonomic fully adjustable suspension heated seat with armrests and seat belt

6 SERIES - OPTIONS





Options	Code
110 V engine block heater	C885255
220 V engine block heater	C885250
2" Hitch receiver (not compatible with C883047)	C883062
3 additional working halogen lights	C883064
3 additional working LED lights	C883018
Additional front hydraulic outlets	C883024
Attachment coupling plate for rear mounting (not compatible with C883047)	C880031
Automatic locking plate	C880015
Backup warning beeper	C883021
Beacon light	C883039
Driver area cover	C880049
Flat face coupling kit	C880221
Floating boom valve	C883011
Fully enclosed cab with sound insulation linen	C883001
GPS tracker	C883075
Heating system	C883072
Left protection bar for operator	C883030
Mirrors	C880081
Polycarbonate back window (smart cabin)	C883035
Polycarbonate right side (smart cabin)	C883034
Polycarbonate windscreen (smart cabin)	C883000
Rear 12V electric socket	C883022
Rear bull bar (not compatible with C883062, C885014 and C880031)	C883047
Rear hydraulic outlets - double	C883014
Rear hydraulic outlets - single	C883013
Rear side weights 80 kg (40 kg + 40 kg) / 176 lbs (88 lbs + 88 lbs)	C883078
Rear side weights 160 kg (2x40 kg + 2x40 kg) / 352 lbs (2x88lbs+2x88lbs)	C883079
Rear weights 180 kg (90 kg + 90 kg) / 396 lbs (198lbs + 198 lbs)	C880054
Skid tires 27x10.50-15, set of 4	C884012

6 SERIES - OPTIONS

Options	Code
Skid tires 27x8.50-15, set of 4	C884011
Snow chains for wheels 23x10.50-12, set of 2	C880046
Snow chains for wheels 23x8.50-12, set of 2	C880041
Snow chains for wheels 26x12.00-12, set of 2	C880042
Snow chains for wheels 27x8.50-15, set of 2	C880045
Tie down bracket on wheel hub, set of 4	C883065
Torque divider	C883600
Tractor tires 23x10.50-12 ET-25, set of 4	C884007
Tractor tires 26x12.00-12 ET-50, set of 4	C884009
Trailer coupling (not compatible with C883047)	C885014
Turf tires 23x10.50-12 ET-25, set of 4	C884008
Turf tires 23x8.50-12, set of 4	C884006
Turf tires 26x12.00-12 ET-50, set of 4	C884010
Warning & Safety lights for road travel (with mirrors)	C883009
Wheel spacer 10 mm (0.4 in), set of 4 (max. 1 pcs for wheel)	C880090
Wheel spacer 55 mm (2.2 in), set of 4 (max. 1 pcs for wheel)	C885010

7 SERIES: 7.2 K

<http://tiny.cc/7seriesEN>

 MAX LIFTING CAPACITY 1380 kg	 ENGINE POWER 25 hp	 SPEED 9 km/h	 FLOW RATE 40 l/min	 LIFT HEIGHT 2,9 m
--	--	--	--	---

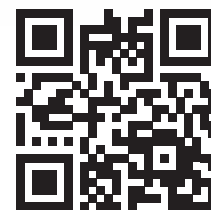

Model	7.2 K
Engine	Kubota D1305 - 3 cylinder - 1261 cc.
Emission Standard	Stage V and Tier 4 Final
Power (Iso Gross) / Torque	25 HP / 85 Nm @ 1700 rpm
Fuel	Diesel
Transmission	Hydrostatic
Drive speed (max.) ⁽¹⁾	9 km/h (5.6 mph)
Aux. hydraulics oil flow	40 l/min (10.5 GPM)
Max. lifting height	2,90 m (114 in)
Tipping load, max. ⁽²⁾	1725 kg (3803 lbs)
Lifting capacity straight, max. ⁽³⁾	1380 kg (3042 lbs)
Breakout force / 50 cm	1700 kg (3748 lbs)
Pushing force (c)	1690 kgf (1690 kp)
Average ground pressure (w/standard tires)	1099 kg/m ² (225 lbs/sqft)
Turning radius: inside/outside	825/2090 mm (32.5/82.3 in)
Standard tires (Tractor profile)	23X10.50-12 ET-25
Weight	1590 kg (3510 lbs)
Product Code	C962025

⁽¹⁾ Maximum speed that can be achieved with the largest diameter tires available, on a flat surface and machine without attachments.

⁽²⁾ Tipping limit, when the machine is straight, with rear weights and boom lifted just off the ground. Weight of attachment included.

⁽³⁾ Maximum load that can be lifted just off the ground when the machine is straight and with rear weights. Weight of attachment is included.

Note: Refer to the Operator's manual for the comprehensive load diagram.

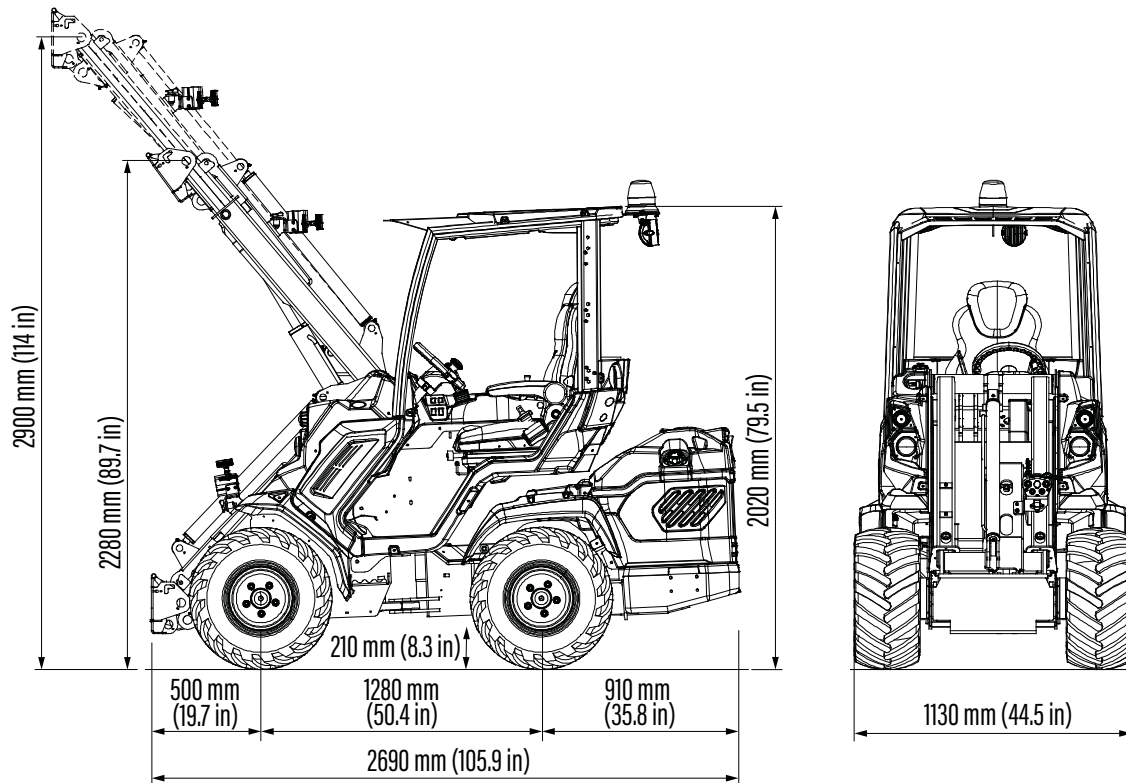

Tires size	Height	Width
23X8.50-12	2020 mm (79.5 in)	1070 mm (42.2 in)
23X10.50-12 ET-25	2020 mm (79.5 in)	1130 mm (44.5 in)
26X12.00-12 ET-50	2040 mm (80.3 in)	1280 mm (50.4 in)
27X8.50-15	2080 mm (81.9 in)	1070 mm (42.1 in)
27X10.50-15	2080 mm (81.9 in)	1150 mm (45.3 in)

FEATURES

- Kubota D1305 (25 HP), big block, 3 cylinder, diesel engine, water cooled, electric start, glow plug
- Stage V and Tier 4 Final compliant engine
- Unbreakable Body Panels
- DBS (Dynamic Block System)
- Self-locking multi-disk parking brake
- Integrated rear weights
- Hydraulic oil cooler
- Hydraulic multiconnector
- Hydraulically pilot operated variable displacement drive pump
- 2 front working lights
- Self-levelling double-H telescopic boom
- 4WD hydrostatic Direct Drive motors, proportional servo control
- 4-functions joystick
- ROPS-FOPS Level I
- LCD graphic display with programmed service
- Ergonomic fully adjustable suspension heated seat with armrests and seat belt
- Radial piston high efficiency and heavy duty wheel motors

7 SERIES - OPTIONS

Options	Code
110 V engine block heater	C885255
220 V engine block heater	C885250
2" Hitch receiver (not compatible with C883036)	C883062
3 additional working halogen lights	C883064
3 additional working LED lights	C883018
Attachment coupling plate for rear mounting	C880031
Automatic locking plate	C880015
Backup warning beeper	C883021
Beacon light	C883039
Driver area cover	C880049
Flat face coupling kit	C880221
Floating boom valve	C883011
Fully enclosed cab with sound insulation linen	C883001
GPS tracker	C883075
Heating system	C883072
Left protection bar for operator	C883030
Mirrors	C880081
Multifunction joystick with ACI	C883080
Polycarbonate back window (smart cabin)	C883035
Polycarbonate right side (smart cabin)	C883034
Polycarbonate windscreen (smart cabin)	C883000
Rear 12V electric socket	C883022
Rear bull bar with side extensions (not compatible with C883062 and C885014)	C883036
Rear hydraulic outlets - double	C883014
Rear hydraulic outlets - single	C883013
Rear side weights 80 kg (40 kg + 40 kg) / 176 lbs (88 lbs + 88 lbs)	C883069
Rear side weights 160 kg (2x40 kg + 2x40 kg) / 352 lbs (2x88lbs+2x88lbs)	C883077
Rear weights 180 kg (90 kg + 90 kg) / 396 lbs (198 lbs + 198 lbs)	C880054
Skid tires 27x10.50-15, set of 4	C884012

7 SERIES - OPTIONS

Options	Code
Skid tires 27x8.50-15, set of 4	C884011
Snow chains for wheels 23x10.50-12, set of 2	C880046
Snow chains for wheels 23x8.50-12, set of 2	C880041
Snow chains for wheels 26x12.00-12, set of 2	C880042
Snow chains for wheels 27x8.50-15, set of 2	C880045
Tie down bracket on wheel hub, set of 4	C883065
Torque divider	C883600
Tractor tires 23x8.50-12, set of 4	C884005
Tractor tires 26x12.00-12 ET-50, set of 4	C884009
Trailer coupling (not compatible with C883036)	C885014
Turf tires 23x10.50-12 ET-25, set of 4	C884008
Turf tires 23x8.50-12, set of 4	C884006
Turf tires 26x12.00-12 ET-50, set of 4	C884010
Warning & Safety lights for road travel (with mirrors)	C883009
Wheel spacer 10 mm (0.4 in), set of 4 (max. 1 pcs for wheel)	C880090
Wheel spacer 55 mm (2.2 in), set of 4 (max. 1 pcs for wheel)	C885010
ACI Upgrade	C090027
EU Certificate of Conformity (CoC) for road approval (7.2 K)	COC

8 SERIES: 8.4S K

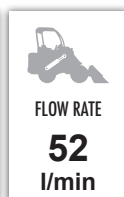
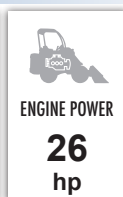
<http://tiny.cc/8seriesEN>

ACI
ATTACHMENT
CONTROL
INTERFACE

CRUISE
CONTROL

Model	8.4S K STAGE V
Engine	Kubota V1505 - 4 cylinder - 1498 cc
Emission Standards	Stage V - TIER 4 Final
Power (Iso Gross) / Torque	26 HP / 93 Nm @ 1700 rpm
Fuel	Diesel
Transmission	Hydrostatic OneDrive
Drive speed (max.) ⁽¹⁾	11 - 22 km/h (6.8 - 13.6 mph)
Aux. hydraulics oil flow	52 l/min (13.7 GPM)
Max. lifting height	2,98 m (117.3 in)
Tipping load, max. ⁽²⁾	1840 kg (4056 lbs)
Lifting capacity straight, max. ⁽³⁾	1470 kg (3240 lbs)
Breakout force / 50 cm	1700 kg (3748 lbs)
Pushing force (c)	2050 kgf (2050 kp)
Average ground pressure (w/std tires)	1025 kg/m ² (210 lbs/sqft)
Turning radius: inside/outside	825/2090 mm (32.5/82.3 in)
Standard tires (Tractor profile)	26X12.00-12 ET-50
Weight	1680 kg (3710 lbs)
Product Code	C963035

⁽¹⁾ Maximum speed that can be achieved with the largest diameter tires available, on a flat surface and machine without attachments.

⁽²⁾ Tipping limit, when the machine is straight, with rear weights and boom lifted just off the ground. Weight of attachment included.

⁽³⁾ Maximum load that can be lifted just off the ground when the machine is straight and with rear weights. Weight of attachment is included.

Note: Refer to the Operator's manual for the comprehensive load diagram.

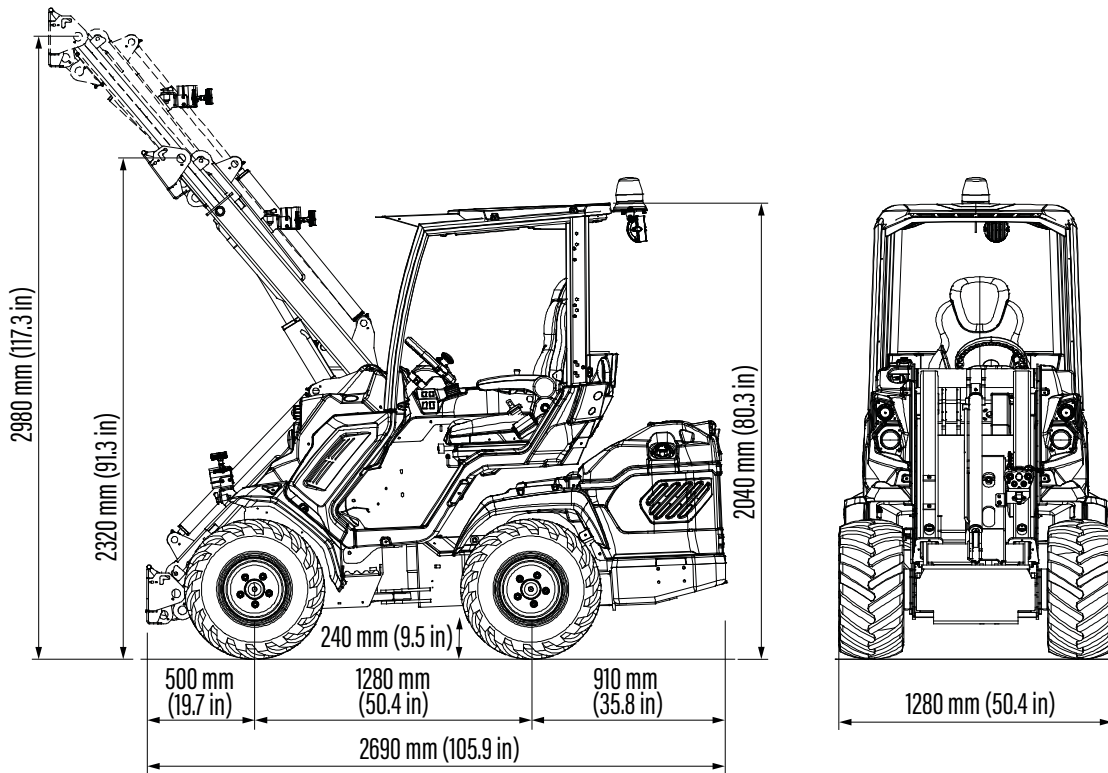

Tires size	Height	Width
23X8.50-12	2020 mm (79.5 in)	1070 mm (42.2 in)
23X10.50-12 ET-25	2020 mm (79.5 in)	1130 mm (44.5 in)
26X12.00-12 ET-50	2040 mm (80.3 in)	1280 mm (50.4 in)
27X8.50-15	2080 mm (81.9 in)	1070 mm (42.1 in)
27X10.50-15	2080 mm (81.9 in)	1150 mm (45.3 in)

FEATURES

- Kubota V1505, 4 cylinder, diesel engine, water cooled, electric start, glow plug
- Stage V and Tier 4 Final compliant engine
- **OneDrive System:** DBS (Dynamic Block System), Cruise Control and Torque Divider activated by Joystick
- ACI with Multifunction joystick (22 functions)
- Unbreakable Body Panels
- 2 Speed
- Hydraulically pilot operated variable displacement drive pump
- Self-locking multi-disk parking brake
- Hi-Flow system
- Integrated rear weights
- Self-levelling double-H telescopic boom
- Radial Piston high efficiency and heavy duty wheel motors
- 4WD hydrostatic Direct Drive motors, proportional servo control
- Hydraulic oil cooler
- Hydraulic multiconnector
- ROPS-FOPS Level I
- LCD graphic display with programmed service
- 2 front working lights
- Ergonomic fully adjustable suspension heated seat with armrests and seat belt

8 SERIES: 8.5S K

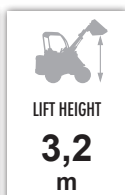
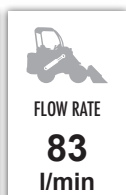
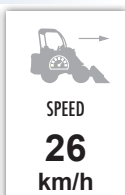
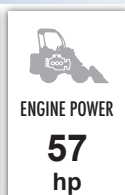
<http://tiny.cc/8seriesEN>**NEW**

ACI
ATTACHMENT
CONTROL
INTERFACE

ONE
DRIVE

CRUISE
CONTROL

Model	8.5S K STAGE V
Engine	Rehiko / Kohler KDI 1903 - 3 cylinder 1861 cc - Turbo common rail
Emission Standards	Stage V
Power (Iso Gross) / Torque	57 HP / 225 Nm @ 1500 rpm
Fuel	Diesel
Transmission	Hydrostatic OneDrive
Drive speed (max.) ⁽¹⁾	13 - 26 km/h (8 - 16 mph)
Aux. hydraulics oil flow	83 l/min (21.9 GPM)
Max. lifting height	3,2 m (126 in)
Tipping load, max. ⁽²⁾	2050 kg (4520 lbs)
Lifting capacity straight, max. ⁽³⁾	1640 kg (3615 lbs)
Breakout force / 50 cm	1700 kg (3748 lbs)
Pushing force (c)	2190 kgf (2190 kp)
Average ground pressure (w/std tires)	890 kg/m ² (182 lbs/sqft)
Turning radius: inside/outside	820/2295 mm (32.2/90.3 in)
Standard tires (Tractor profile)	400/50-15 (31x15.50-15) ET-100
Weight	1790 kg (3946 lbs)
Product Code	C964008

⁽¹⁾ Maximum speed that can be achieved with the largest diameter tires available, on a flat surface and machine without attachments.

⁽²⁾ Tipping limit, when the machine is straight, with rear weights and boom lifted just off the ground. Weight of attachment included.

⁽³⁾ Maximum load that can be lifted just off the ground when the machine is straight and with rear weights. Weight of attachment is included.

Note: Refer to the Operator's manual for the comprehensive load diagram.

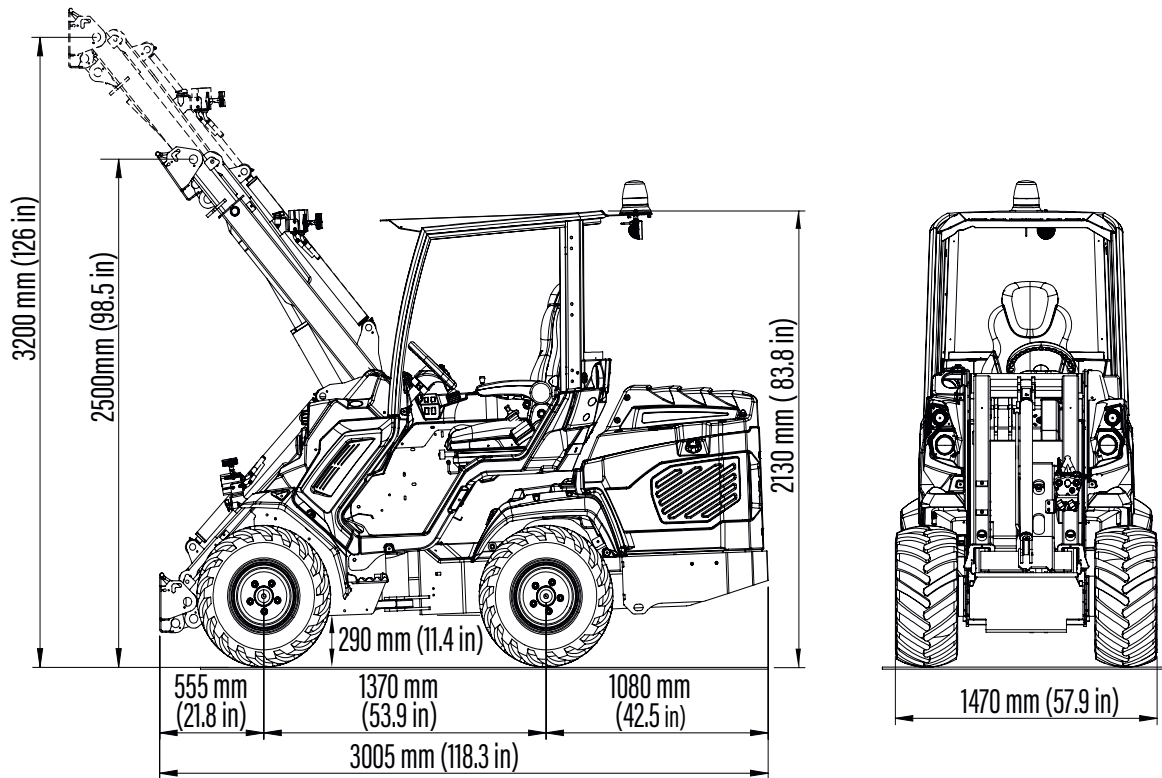

Tires size	Height	Width
400/50-15 (31X15.50-15) ET-100	2130 mm (83.8 in)	1470 mm (57.9 in)

FEATURES

- Rehlko / Kohler KDI1903TCR, 3 cyl., Turbo common rail diesel engine, 1861 cc, water cooled with electric start
- STAGE V
- DPF
- ETC - Electronic Throttle Control
- **OneDrive System:** DBS (Dynamic Block System), Cruise Control and Torque Divider activated by Joystick
- ACI with Multifunction joystick (22 functions)
- Unbreakable Body Panels
- Hydraulically pilot operated variable displacement drive pump
- Hi-Flow system
- 2 Speed
- Self-locking multi-disk parking brake
- Self-levelling double-H telescopic boom
- Radial Piston high efficiency and heavy duty wheel motors
- 4WD hydrostatic Direct Drive motors, proportional servo control
- Hydraulic oil cooler
- Hydraulic multiconnector
- ROPS-FOPS Level I
- LCD graphic display with programmed service
- 2 front working lights
- Ergonomic fully adjustable suspension heated seat with armrests and seat belt

8 SERIES - OPTIONS





Options	Code
110 V engine block heater	C885255
220 V engine block heater	C885250
2" Hitch receiver (not compatible with C883036 and C883066)	C883062
3 additional working halogen lights	C883064
3 additional working LED lights	C883018
A/C system with heating for fully enclosed cab - for 8.5S K models (C883001 required - not aftermarket)	C883801
Additional front hydraulic outlets	C883024
Attachment coupling plate for rear mounting (not compatible with C883036 and C883066)	C880031
Automatic locking plate	C880015
Backup warning beeper	C883021
Beacon light	C883039
Driver area cover	C880049
Flat face coupling kit	C880221
Floating boom valve	C883011
Fully enclosed cab with sound insulation linen	C883001
GPS tracker	C883075
Heating system for 8.4S K	C883072
Heating system for 8.5S K	C883074
Left protection bar for operator	C883030
Mirrors	C880081
Polycarbonate back window (smart cabin)	C883035
Polycarbonate right side (smart cabin)	C883034
Polycarbonate windscreen (smart cabin)	C883000
Rear 12V electric socket (only 8.4Sk)	C883022
Rear 12V electric socket (only 8.5SK)	C883023
Rear bull bar with side extensions (not compatible with C883062-C885014-C880031) for 8.4S K	C883036
Rear bull bar with side extensions (not compatible with C883062-C885014-C880031) for 8.5S K	C883066
Rear hydraulic outlets - double for 8.4S K	C883014
Rear hydraulic outlets - double for 8.5S K	C883805

8 SERIES - OPTIONS

Options	Code
Rear hydraulic outlets - single for 8.4S K	C883013
Rear hydraulic outlets - single for 8.5S K	C883015
Rear side weights 80 kg (40 kg + 40 kg) / 176 lbs (88 lbs + 88 lbs)	C883069
Rear side weights 160 kg (2x40 kg + 2x40 kg) / 352 lbs (2x88lbs+2x88lbs)	C883077
Rear weights 180 kg (90 kg + 90 kg) / 396 lbs (198lbs + 198 lbs)	C880054
Skid tires 27x10.50-15, set of 4 for 8.4S K	C884012
Skid tires 27x8.50-15, set of 4 for 8.4S K	C884011
Snow chains for wheels 23x10.50-12, set of 2	C880046
Snow chains for wheels 23x8.50-12, set of 2	C880041
Snow chains for wheels 26x12.00-12, set of 2	C880042
Snow chains for wheels 27x8.50-15, set of 2	C880045
Tie down bracket on wheel hub, set of 4	C883065
Tractor tires 23x10.50-12 ET-25, set of 4 for 8.4S K	C884007
Tractor tires 23x8.50-12, set of 4 for 8.4S K	C884005
Tractor tires 26x12.00-12 ET-50, set of 4 for 8.4S K	C884009
Trailer coupling (not compatible with C883036 and C883066)	C885014
Turf tires 23x10.50-12 ET-25, set of 4 for 8.4S K	C884008
Turf tires 23x8.50-12, set of 4 for 8.4S K	C884006
Turf tires 26x12.00-12 ET-50, set of 4 for 8.4S K	C884010
Turf tires 400/50-15 (31x15.50-15 ET -100), set of 4 for 8.5S K	C884014
Warning & Safety lights for road travel (with mirrors)	C883009
Wheel spacer 10 mm (0.4 in), set of 4 (max. 1 pcs for wheel) (not with 400/50-15 ET-100)	C880090
Wheel spacer 55 mm (2.2 in), set of 4 (not with 400/50-15 ET-100)	C885010
EU Certificate of Conformity (CoC) for road approva).	COC

11 SERIES: 11.6 K

<http://tiny.cc/11seriesEN>

 MAX LIFTING CAPACITY 2540 kg	 ENGINE POWER 57 hp	 SPEED 30 km/h	 FLOW RATE 84 l/min	 LIFT HEIGHT 3,7 m
--	--	---	--	---



CRUISE
CONTROL



ONE
DRIVE

ACI
ATTACHMENT
CONTROL
INTERFACE

Model	11.6 K STAGE V
Engine	Rehiko / Kohler KDI 1903 - 3 cylinder 1861 cc - Turbo common rail
Emission Standard	Stage V
Power (Iso Gross) / Torque	57 HP / 225 Nm @ 1500 rpm
Fuel	Diesel
Transmission	Hydrostatic OneDrive
Drive speed (max.) - 2 speed ⁽¹⁾	15-30 km/h (9.3-18.6 mph)
Aux. hydraulics oil flow	84 l/min (22.2 GPM)
Max. lifting height	3,7 m (145.6 in)
Tipping load, max. ⁽²⁾	3180 kg (7010 lbs)
Lifting capacity straight, max. ⁽³⁾	2540 kg (5600 lbs)
Breakout force / 50 cm	3000 kg (6614 lbs)
Pushing force (c)	2650 kgf (2650 kp)
Average ground pressure (w/standard tires)	932 kg/m ² (192 lbs/sqft)
Turning radius: inside/outside	1135/2635 mm (44.7/ 103.7 in)
Standard tires (Tractor profile)	380/55-17
Weight	2320 kg (5115 lbs)
Product Code	C968100

⁽¹⁾ Maximum speed that can be achieved with the largest diameter tires available, on a flat surface and machine without attachments.

⁽²⁾ Tipping limit, when the machine is straight, with rear weights and boom lifted just off the ground. Weight of attachment included.

⁽³⁾ Maximum load that can be lifted just off the ground when the machine is straight and with rear weights. Weight of attachment is included.

Note: Refer to the Operator's manual for the comprehensive load diagram.

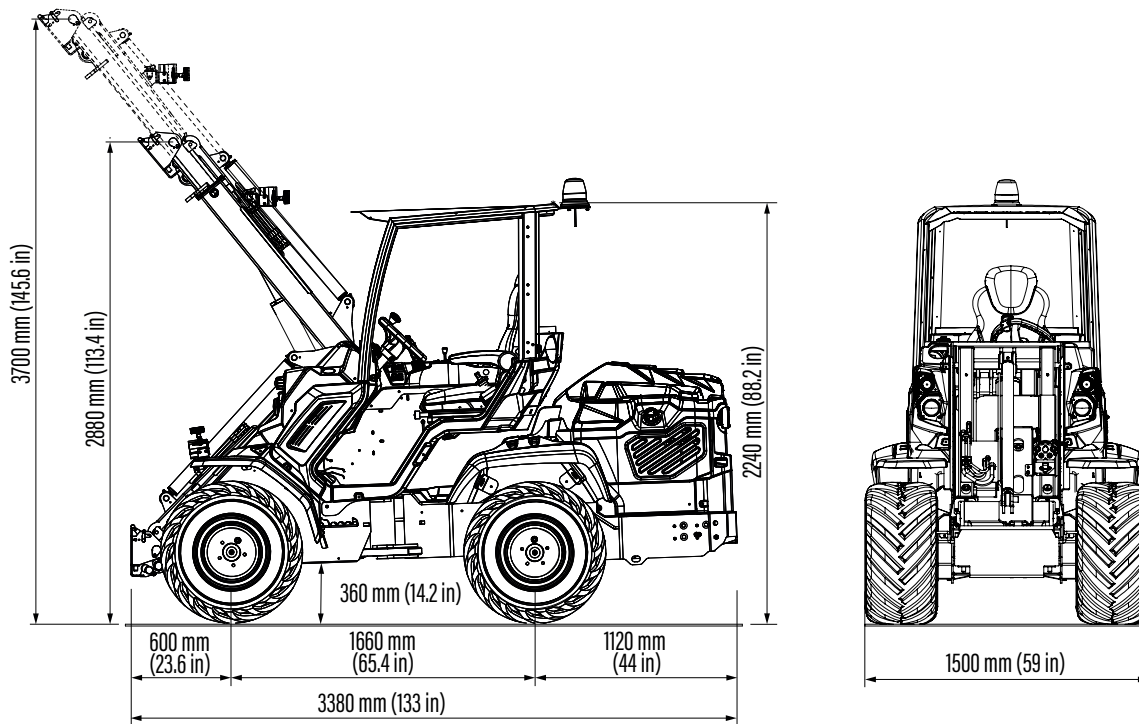





Tires size	Height	Width
380/55-17	2240 mm (88.2 in)	1500 mm (59 in)
400/50-15 (31X15.50-15)	2195 mm (86.4 in)	1500 mm (59 in)

FEATURES

- Rehlko / Kohler KDI1903TCR, 3 cyl., Turbo common rail, 1861 cc, diesel engine, water cooled with electric start
- STAGE V
- DPF
- **OneDrive System:** DBS (Dynamic Block System), Cruise Control and Torque Divider activated by Joystick
- ETC - Electronic Throttle Control
- ACI with Multifunction joystick (22 functions)
- Unbreakable Body Panels
- 2 Speed
- Hydraulically pilot operated variable displacement drive pump
- Hi-Flow system
- Self-locking multi-disk parking brake
- Self-levelling double-H telescopic boom
- Radial Piston high efficiency and heavy duty wheel motors
- 4WD hydrostatic Direct Drive motors, proportional servo control
- Hydraulic oil cooler
- Hydraulic multiconnector
- ROPS-FOPS Level I
- LCD graphic display with programmed service
- 2 front working lights
- Ergonomic fully adjustable suspension heated seat with armrests and seat belt

11 SERIES: 11.9 K

<http://tiny.cc/11seriesEN>

 MAX LIFTING CAPACITY 2620 kg	 ENGINE POWER 75 hp	 SPEED 35 km/h	 FLOW RATE 95 l/min	 LIFT HEIGHT 3,7 m
--	--	---	--	---

CRUISE
CONTROL



ONE
DRIVE

ACI
ATTACHMENT
CONTROL
INTERFACE



Model	11.9 K STAGE V
Engine	Rehiko / Kohler KDI 2504 - 4 cylinder - 2482 cc
Emission Standard	Stage V
Power (Iso Gross) / Torque	75 HP / 300 Nm @ 1500 rpm
Fuel	Diesel
Transmission	Hydrostatic OneDrive
Drive speed (max.) - 2 speed ⁽¹⁾	17 - 35 km/h (10.5 - 21.5 mph)
Aux. hydraulics oil flow	95 l/min (25 GPM)
Max. lifting height	3,7 m (145.6 in)
Tipping load, max. ⁽²⁾	3280 kg (7231 lbs)
Lifting capacity straight, max. ⁽³⁾	2620 kg (5776 lbs)
Breakout force / 50 cm	3150 kg (6945 lbs)
Pushing force (c)	2650 kgf (2650 kp)
Average ground pressure (w/standard tires)	964 kg/m ² (197 lbs/sqft)
Turning radius: inside/outside	1135/2635 mm (44.7/ 103.7 in)
Standard tires (Tractor profile)	380/55-17
Weight	2400 kg (5291 lbs)
Product Code	C968200

⁽¹⁾ Maximum speed that can be achieved with the largest diameter tires available, on a flat surface and machine without attachments.

⁽²⁾ Tipping limit, when the machine is straight, with rear weights and boom lifted just off the ground. Weight of attachment included.

⁽³⁾ Maximum load that can be lifted just off the ground when the machine is straight and with rear weights. Weight of attachment is included.

Note: Refer to the Operator's manual for the comprehensive load diagram.

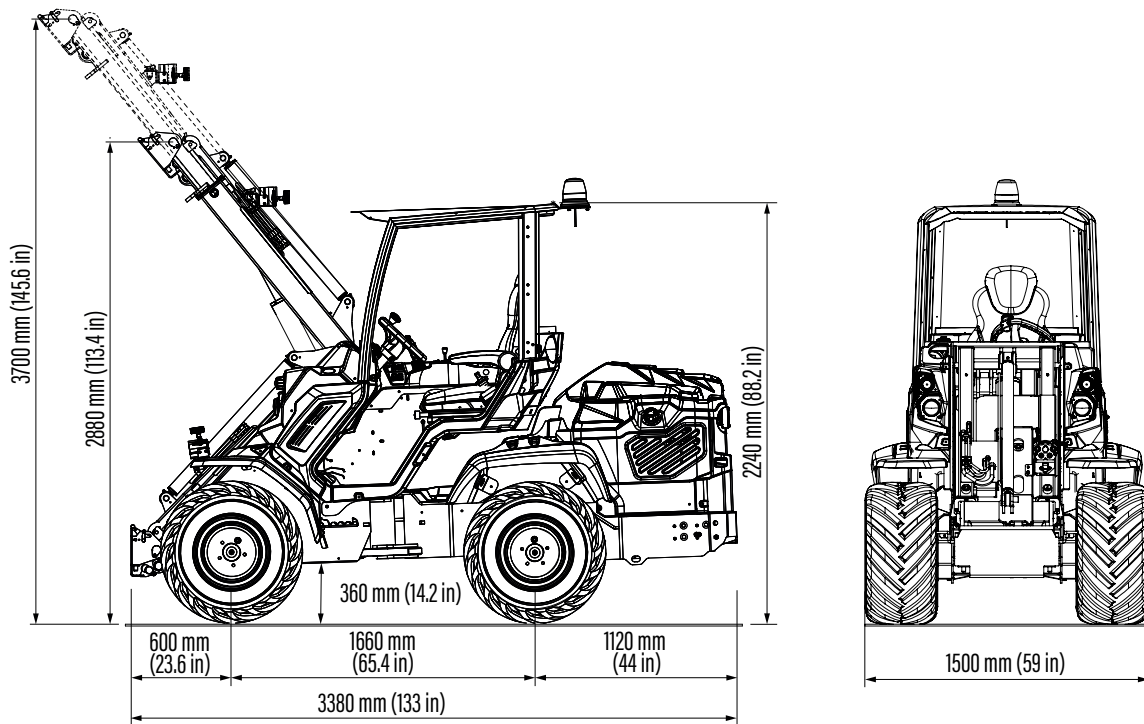

Tires size	Height	Width
380/55-17	2240 mm (88.2 in)	1500 mm (59 in)
400/50-15 (31X15.50-15)	2195 mm (86.4 in)	1500 mm (59 in)

FEATURES

- Rehlko / Kohler KDI2504, 4 cyl., Turbo common rail diesel engine, 2482 cc, water cooled with electric start
- STAGE V
- DPF
- **OneDrive System:** DBS (Dynamic Block System), Cruise Control and Torque Divider activated by Joystick
- ETC - Electronic Throttle Control
- ACI with Multifunction joystick (22 functions)
- Unbreakable Body Panels
- 2 Speed
- Hydraulically pilot operated variable displacement drive pump
- Hi-Flow system
- Self-locking multi-disk parking brake
- Self-levelling double-H telescopic boom
- Radial Piston high efficiency and heavy duty wheel motors
- 4WD hydrostatic Direct Drive motors, proportional servo control
- Hydraulic oil cooler
- Hydraulic multiconnector
- ROPS-FOPS Level I
- LCD graphic display with programmed service
- 2 front working lights
- Ergonomic fully adjustable suspension heated seat with armrests and seat belt

11 SERIES - OPTIONS

Options	Code
110 V engine block heater	C885255
220 V engine block heater	C885250
2" Hitch receiver (not compatible with C883037)	C883063
3 additional working halogen lights	C883064
3 additional working LED lights	C883018
A/C system with heating for fully enclosed cab (C883001 required - not aftermarket)	C883902
Additional front hydraulic outlets	C883082
Attachment coupling plate for rear mounting (not compatible with C883037)	C880031
Automatic locking plate	C880015
Backup warning beeper	C883021
Beacon light	C883039
Driver area cover	C880049
Flat face coupling kit	C880221
Floating boom valve	C883011
Fully enclosed cab with sound insulation linen	C883001
GPS tracker	C883075
Heating system	C883074
Left protection bar for operator	C883030
Mirrors	C880081
Polycarbonate back window (smart cabin)	C883035
Polycarbonate right side (smart cabin)	C883034
Polycarbonate windscreen (smart cabin)	C883000
Rear 12V electric socket	C883023
Rear bull bar with side extensions (not compatible with C883063, C885017 and C880031)	C883037
Rear hydraulic outlets - double	C883016
Rear hydraulic outlets - single	C883015
Rear weights (440 kg / 970 lbs)	C885025
Rear side weights 80 kg (40 kg + 40 kg) / 176 lbs (88 lbs + 88 lbs)	C883069
Rear side weights 160 kg (2x40 kg + 2x40 kg) / 352 lbs (2x88lbs+2x88lbs)	C883077

11 SERIES - OPTIONS

Options	Code
Rear weights 180 kg (90 kg + 90 kg) / 396 lbs (198lbs + 198 lbs)	C880054
Rubber tracks for 11 series (The kit weights 750 kg / 1655 lbs and increases the height of the machine by 1,5 cm / 0,6 in)	C883107
Snow chains for wheels, 400/50-15 (31x15.50-15), set of 2	C880044
Snow chains for wheels, 380/55-17, set of 2	C880047
Tie down bracket on wheel hub, set of 4	C883065
Tractor tires 400/50-15 (31x15.50-15), set of 4	C884016
Trailer coupling (not compatible with C883037)	C885017
Turf tires 400/50-15 (31x15.50-15), set of 4	C884013
Turf tires 380/55-17, set of 4	C884017
Warning & Safety lights for road travel (with mirrors)	C883010
Wheel spacer 10 mm (0.4 in), set of 4 (max. 1 pcs for wheel)	C880090
Wheel spacer 55 mm (2.2 in), set of 4 (max. 1 pcs for wheel)	C885010
EU Certificate of Conformity (CoC) for road approval (only Stage 5 models)	COC

EZ SERIES: EZ5

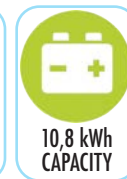
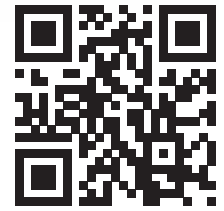
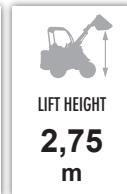
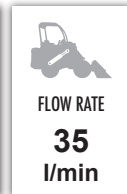
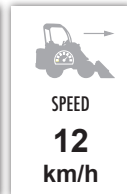
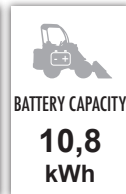
<http://tiny.cc/EZ5seriesEN>

Model	EZ 5
Transmission	Hydrostatic
Drive speed (max.) ⁽¹⁾	12 km/h (7.5 mph)
Aux. hydraulics oil flow	35 l/min (9.3 GPM)
Max. lifting height	2,75 m (108 in)
Tipping load, max. ⁽²⁾	1110 kg (2447 lbs)
Lifting capacity straight, max. ⁽³⁾	890 kg (1962 lbs)
Breakout force / 50 cm	800 kg (1764 lbs)
Pushing force (c)	900 kgf (900 kp)
Average ground pressure (w/standard tires)	814 kg/m ² (167 lbs/sqft)
Turning radius: inside/outside	800/2000 mm (31.5/78.7 in)
Standard tires (Tractor profile)	23x10.50-12 ET-25
Weight	1020 kg (2250 lbs)
Product Code (Standard)	C977060
EZ5 Pack 1 (ACI with Multifunction joystick)	C977061

Electric system and battery	
Battery type	LiFePO4
Battery capacity	10,8 kWh
Operation time ⁽⁴⁾ ECO MODE	3 h
Operation time ⁽⁴⁾ POWER MODE	2 h
Electric motors	2
Charging system	Integrated charger
Charger type	Sealed single-phase
Charger Input Voltage	110 - 230 ± 10% VAC
Charger Input Frequency	50 ÷ 60 Hz
Charger Absorbed Current	Max. 14 A
Charging Current (230 VAC)	Max. 60 A
Charging Current (120 VAC)	Max. 30 A
Charger plug type	CEE 2P+T
Charger Protection	Output short-circuit, Inverse polarity

⁽¹⁾ Maximum speed that can be achieved with the largest diameter tires available, on a flat surface and machine without attachments.

⁽²⁾ Tipping limit, when the machine is straight, with rear weights and boom lifted just off the ground. Weight of attachment included.

⁽³⁾ Maximum load that can be lifted just off the ground when the machine is straight and with rear weights. Weight of attachment is included.

⁽⁴⁾ The operation time of machine varies highly depending on the type of work it is performing. No hydraulic attachments used.

Note: Refer to the Operator's manual for the comprehensive load diagram.

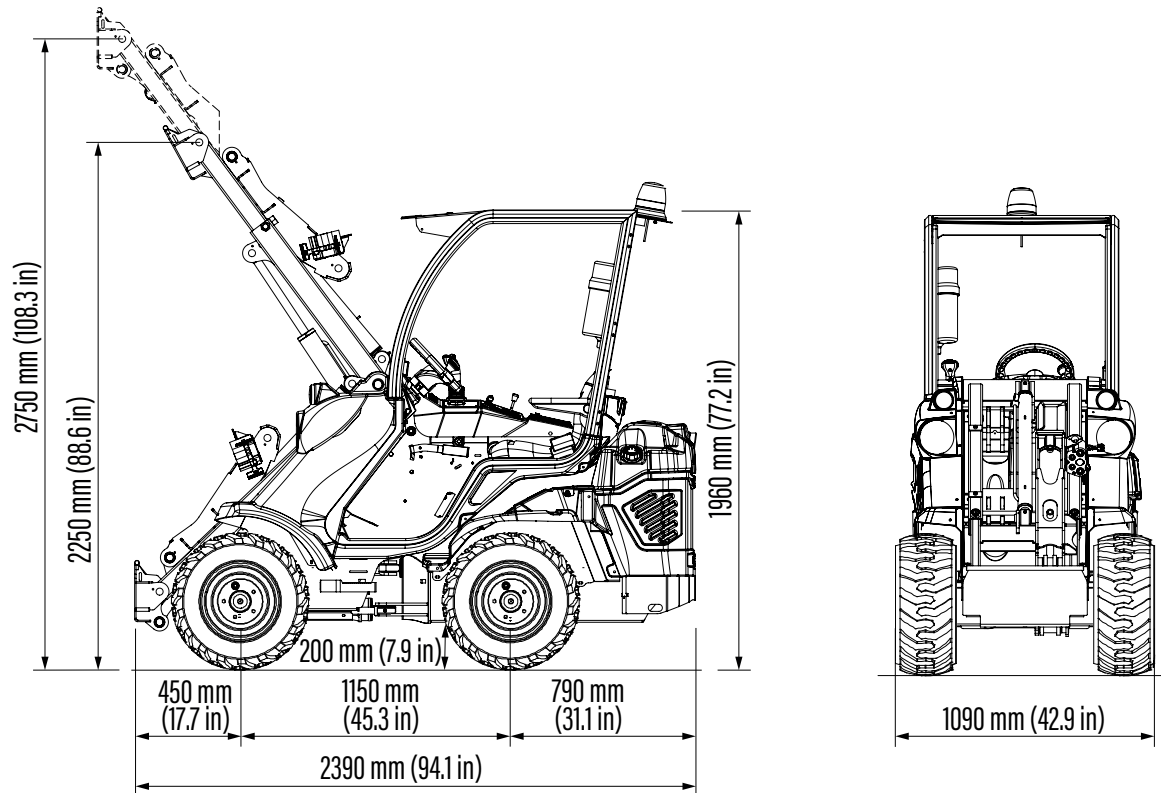

Tires size	Height	Width
23x8.50-12	1960 mm (77.2 in)	980 mm (38.6 in)
23x10.50-12 ET-25	1960 mm (77.2 in)	1090 mm (42.9 in)
27x8.50-15	2010 mm (79.1 in)	1000 mm (39.4 in)
26x12.00-12 ET-50	1998 mm (78.6 in)	1200 mm (47.2 in)

FEATURES

- Twin Motors Single Ended Circuits
- LI-ION Battery
- Integrated Smart Battery Charger
- Zero Emission
- Low Noise
- Braking Energy Recovery System
- Unbreakable Body Panels
- 4WD hydrostatic Direct Drive motors
- DBS (Dynamic Block System)
- Self-levelling double-H telescopic boom
- ACI with Multifunction joystick (22 functions) on Pack 1
- Self-locking parking brake
- LCD graphic display with programmed service
- 2 front led working lights
- Ergonomic full adjustable suspension seat with armrests and seat belt
- High efficiency wheel motors
- Hydraulic multiconnector
- ROPS-FOPS Level I

EZ SERIES: EZ5 LONG RANGE

<http://tiny.cc/EZseries-EN>
NEW
LONG RANGE

MAX LIFTING CAPACITY
890
 kg

BATTERY CAPACITY
14,6
 kWh

SPEED
12
 km/h

FLOW RATE
35
 l/min

LIFT HEIGHT
2,75
 m

LiION
 BATTERY

Model	EZ 5 Long Range
Transmission	Hydrostatic
Drive speed (max.) ⁽¹⁾	12 km/h (7.5 mph)
Aux. hydraulics oil flow	35 l/min (9.3 GPM)
Max. lifting height	2,75 m (108 in)
Tipping load, max. ⁽²⁾	1110 kg (2447 lbs)
Lifting capacity straight, max. ⁽³⁾	890 kg (1962 lbs)
Breakout force / 50 cm	800 kg (1764 lbs)
Pushing force (c)	900 kgf (900 kp)
Average ground pressure (w/standard tires)	814 kg/m ² (167 lbs/sqft)
Turning radius: inside/outside	800/2000 mm (31.5/78.7 in)
Standard tires (Tractor profile)	23x10.50-12 ET-25
Weight	1020 kg (2250 lbs)
Product Code (Standard)	C977062
EZ5 Long Range Pack 1 (ACI with Multifunction joystick)	C977063

Electric system and battery

Battery type	LiFePO4
Battery capacity	14,6 kWh
Operation time ⁽⁴⁾ ECO MODE	4 h
Operation time ⁽⁴⁾ POWER MODE	3 h
Electric motors	2
Charging system	Integrated charger
Charger type	Sealed single-phase
Charger Input Voltage	110 - 230 ± 10% VAC
Charger Input Frequency	50 ÷ 60 Hz
Charger Absorbed Current	Max. 14 A
Charging Current (230 VAC)	Max. 60 A
Charging Current (120 VAC)	Max. 30 A
Charger plug type	CEE 2P+T
Charger Protection	Output short-circuit, Inverse polarity

⁽¹⁾ Maximum speed that can be achieved with the largest diameter tires available, on a flat surface and machine without attachments.

⁽²⁾ Tipping limit, when the machine is straight, with rear weights and boom lifted just off the ground. Weight of attachment included.

⁽³⁾ Maximum load that can be lifted just off the ground when the machine is straight and with rear weights. Weight of attachment is included.

⁽⁴⁾ The operation time of machine varies highly depending on the type of work it is performing. No hydraulic attachments used.

Note: Refer to the Operator's manual for the comprehensive load diagram.

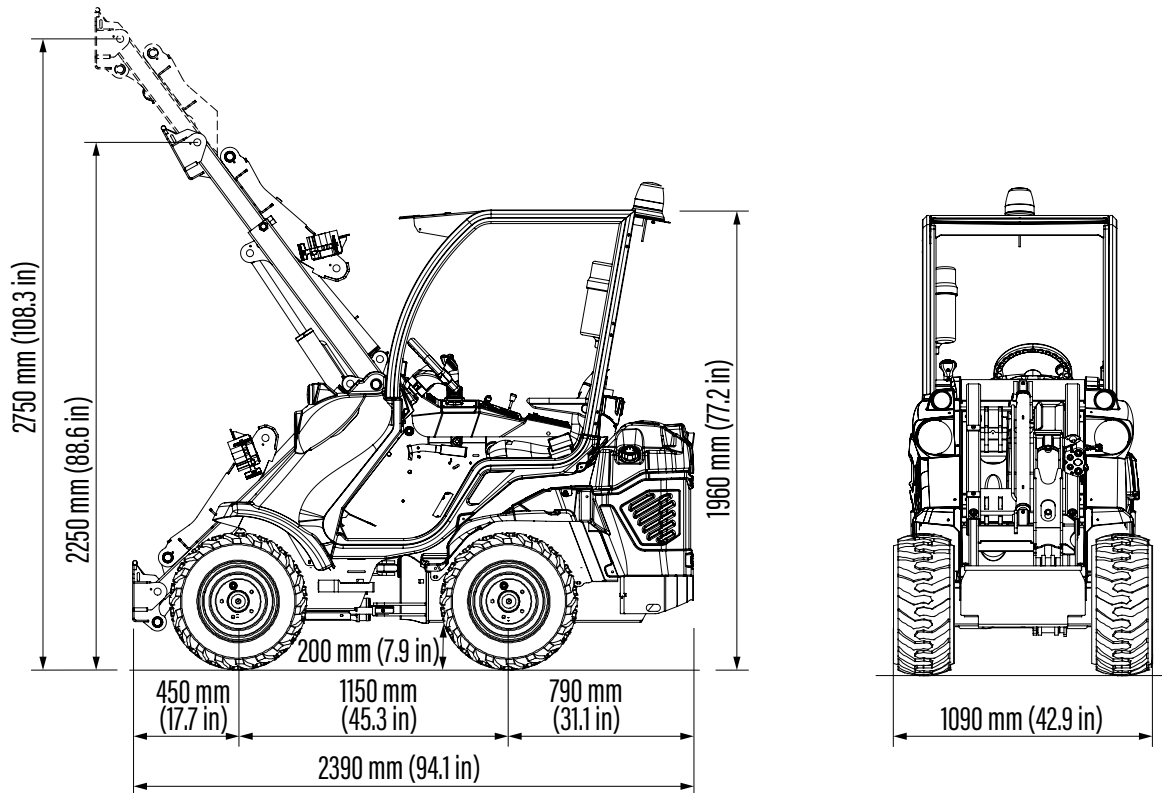

Tires size	Height	Width
23x8.50-12	1960 mm (77.2 in)	980 mm (38.6 in)
23x10.50-12 ET-25	1960 mm (77.2 in)	1090 mm (42.9 in)
27x8.50-15	2010 mm (79.1 in)	1000 mm (39.4 in)
26x12.00-12 ET-50	1998 mm (78.6 in)	1200 mm (47.2 in)

FEATURES

- Twin Motors Single Ended Circuits
- LI-ION Battery
- Integrated Smart Battery Charger
- Zero Emission
- Low Noise
- Braking Energy Recovery System
- Unbreakable Body Panels
- 4WD hydrostatic Direct Drive motors
- DBS (Dynamic Block System)
- Self-levelling double-H telescopic boom
- ACI with Multifunction joystick (22 functions) on Pack 1
- Self-locking parking brake
- LCD graphic display with programmed service
- 2 front led working lights
- Ergonomic full adjustable suspension seat with armrests and seat belt
- High efficiency wheel motors
- Hydraulic multiconnector
- ROPS-FOPS Level I

EZ 5 - OPTIONS





Options	Code
2" Hitch receiver (not compatible with C883047)	C883062
Automatic coupling plate	C880016
Attachment coupling plate for rear mounting (not compatible with C883047)	C880031
Beacon light	C883039
Driver area cover	C880049
Fast charging station 95A	C883809
Fast charging station 160A	C883808
Flat face coupling kit	C880221
Floating boom valve	C885223
GPS tracker	C883075
Left protection bar for operator	C885026
Mirrors	C880081
Polycarbonate back window (smart cabin)	C883508
Polycarbonate right side (smart cabin)	C883507
Polycarbonate windscreen (smart cabin)	C883506
Rear bull bar (not compatible with C883062, C885014 and C880031)	C883047
Rear side weights 80 kg (40 kg + 40 kg) / 176 lbs (88 lbs + 88 lbs)	C883076
Rear weights 180 kg (90 kg + 90 kg) / 396 lbs (198 lbs + 198 lbs)	C880054
Skid tires 27x8.50-15, set of 4	C884011
Snow chains for wheels 23x10.50-12, set of 2	C880046
Snow chains for wheels 23x8.50-12, set of 2	C880041
Snow chains for wheels 26x12.00-12, set of 2	C880042
Tie down bracket on wheel hub, set of 4	C883068
Torque divider	C883600
Tractor tires 23x10.50-12 ET-25, set of 4	C884007

EZ 5 - OPTIONS

Options	Code
Tractor tires 23x8.50-12, set of 4	C884005
Tractor tires 26x12.00-12 ET-50, set of 4	C884009
Trailer coupling (not compatible with C883047)	C885014
Turf tires 23x10.50-12 ET-25, set of 4	C884008
Turf tires 23x8.50-12, set of 4	C884006
Turf tires 26x12.00-12 ET-50, set of 4	C884010
Warning & Safety lights for road travel (with mirrors)	C883513
Wheel spacer 10 mm (0.4 in), set of 4 (max. 2 pcs for wheel)	C880090
Wheel spacer 55 mm (2.2 in), set of 4 (max. 1 pcs for wheel)	C885010
ACI upgrade	C090027

EZ SERIES: EZ7

<http://tiny.cc/EZseries-EN>

 MAX LIFTING CAPACITY 1650 kg	 BATTERY CAPACITY 16,5 kWh	 SPEED 12 km/h	 FLOW RATE 35 l/min	 LIFT HEIGHT 2,98 m
--	---	---	--	--

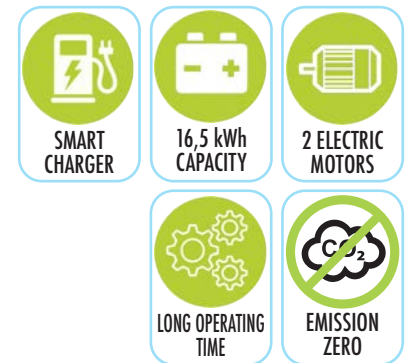
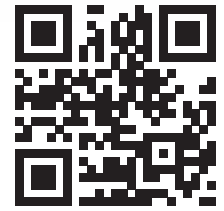

Model	EZ 7
Transmission	Hydrostatic
Drive speed (max.) ⁽¹⁾	12 km/h (7.5 mph)
Aux. hydraulics oil flow	35 l/min (9.3 GPM)
Max. lifting height	2,98 m (117.3 in)
Tipping load, max. ⁽²⁾	2070 kg (4563 lbs)
Lifting capacity straight, max. ⁽³⁾	1650 kg (3637 lbs)
Breakout force / 50 cm	1700 kg (3748 lbs)
Pushing force (c)	2050 kgf (2050 kp)
Average ground pressure (w/standard tires)	1135 kg/m ² (232 lbs/sqft)
Turning radius: inside/outside	825/2090 mm (32.5/82.3 in)
Standard tires (Tractor profile)	26X12.00-12 ET-50
Weight	1860 kg (4110 lbs)
Product Code	C962021
EZ7 Pack 1 (ACI with Multifunction joystick)	C962022

Electric system and battery	
Battery type	Lead Acid
Battery capacity	16,5 kWh
Operation time ⁽⁴⁾ ECO MODE	3 h
Operation time ⁽⁴⁾ POWER MODE	2 h
Electric motors	2
Charging system	Integrated charger
Charger type	Sealed single-phase
Charger Input Voltage	110 - 230 ± 10% VAC
Charger Input Frequency	50 ÷ 60 Hz
Charger Absorbed Current	Max. 14 A
Charging Current (230 VAC)	Max. 60 A
Charging Current (120 VAC)	Max. 30 A
Charger plug type	CEE 2P+T
Charger Protection	Output short-circuit, Inverse polarity

⁽¹⁾ Maximum speed that can be achieved with the largest diameter tires available, on a flat surface and machine without attachments.

⁽²⁾ Tipping limit, when the machine is straight, with rear weights and boom lifted just off the ground. Weight of attachment included.

⁽³⁾ Maximum load that can be lifted just off the ground when the machine is straight and with rear weights. Weight of attachment is included.

⁽⁴⁾ The operation time of machine varies highly depending on the type of work it is performing. No hydraulic attachments used.

Note: Refer to the Operator's manual for the comprehensive load diagram.

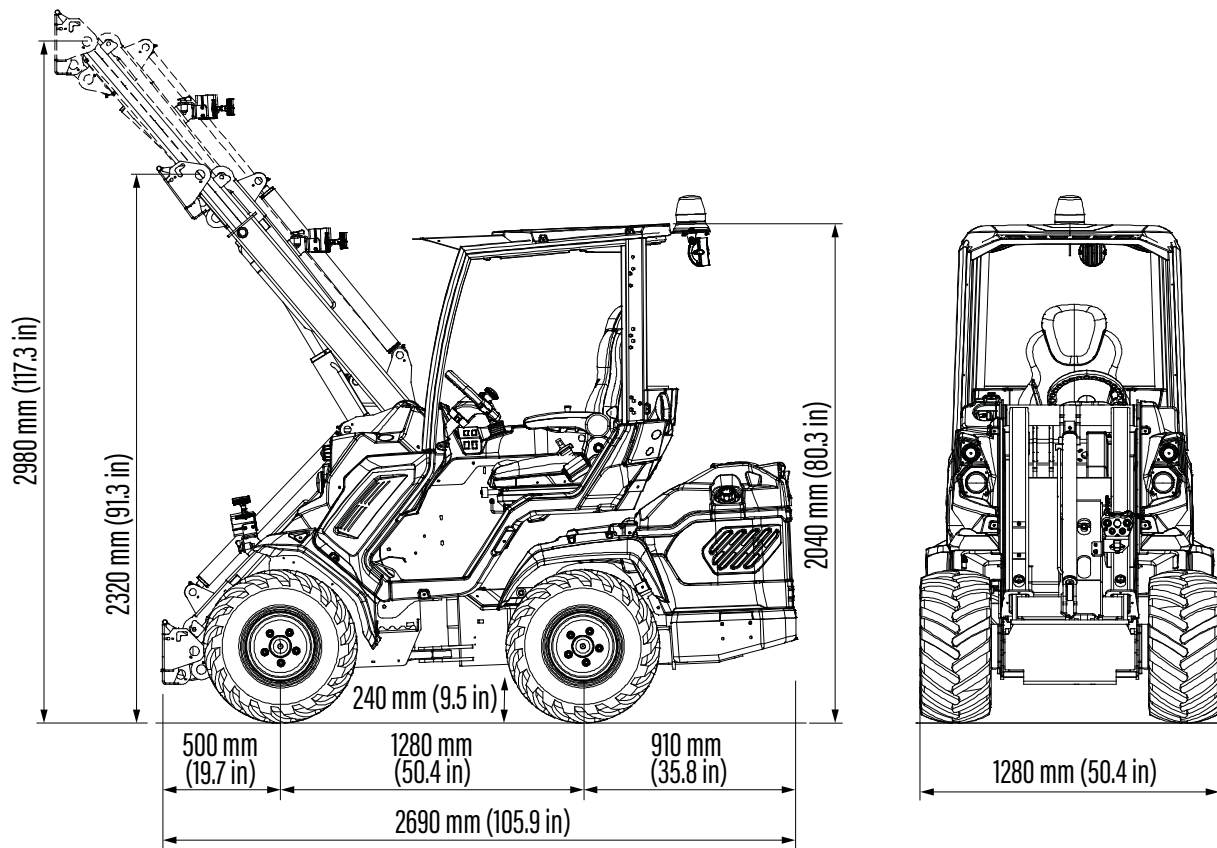

Tires size	Height	Width
23X8.50-12	2020 mm (79.5 in)	1070 mm (42.2 in)
23X10.50-12 ET-25	2020 mm (79.5 in)	1130 mm (44.5 in)
26X12.00-12 ET-50	2040 mm (80.3 in)	1280 mm (50.4 in)
27X8.50-15	2080 mm (81.9 in)	1070 mm (42.1 in)
27X10.50-15	2080 mm (81.9 in)	1150 mm (45.3 in)

FEATURES

- Twin Motors Single Ended Circuits
- Lead Acid Battery
- Integrated Smart Battery Charger
- Zero Emission
- Low Noise
- Braking Energy Recovery System
- Unbreakable Body Panels
- 4WD hydrostatic Direct Drive motors
- DBS (Dynamic Block System)
- Self-levelling double-H telescopic boom
- ACI with Multifunction joystick (22 functions) on Pack 1
- Self-locking multi-disk parking brake
- LCD graphic display with programmed service
- 2 front led working lights
- Ergonomic full adjustable suspension seat with armrests and seat belt
- Radial piston high efficiency and heavy duty wheel motors
- Hydraulic multiconnector
- ROPS-FOPS Level I

EZ SERIES: EZ8

<http://tiny.cc/EZseries-EN>



MAX LIFTING CAPACITY
1420
kg



BATTERY CAPACITY
21,5
kWh



SPEED
12
km/h



FLOW RATE
35
l/min



LIFT HEIGHT
2,98
m

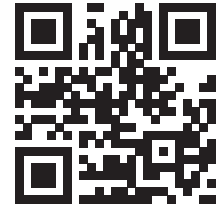

LiION
BATTERY

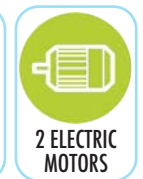
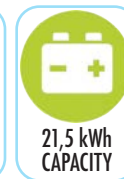

Model	EZ 8
Transmission	Hydrostatic
Drive speed (max.) ⁽¹⁾	12 km/h (7.5 mph)
Aux. hydraulics oil flow	35 l/min (9.3 GPM)
Max. lifting height	2,98 m (117.3 in)
Tipping load, max. ⁽²⁾	1780 kg (3924 lbs)
Lifting capacity straight, max. ⁽³⁾	1420 kg (3130 lbs)
Breakout force / 50 cm	1700 kg (3748 lbs)
Pushing force (c)	2050 kgf (2050 kp)
Average ground pressure (w/standard tires)	958 kg/m ² (196 lbs/sqft)
Turning radius: inside/outside	825/2090 mm (32.5/82.3 in)
Standard tires (Tractor profile)	26X12.00-12 ET-50
Weight	1570 kg (3470 lbs)
Product Code	C963021
EZ8 Pack 1 (ACI with Multifunction joystick)	C963022

Electric system and battery

Battery type	LiFePO4
Battery capacity	21,5 kWh
Operation time ⁽⁴⁾ ECO MODE	4,5 h
Operation time ⁽⁴⁾ POWER MODE	3 h
Electric motors	2
Charging system	Integrated charger
Charger type	Sealed single-phase
Charger Input Voltage	110 - 230 ± 10% VAC
Charger Input Frequency	50 ÷ 60 Hz
Charger Absorbed Current	Max. 14 A
Charging Current (230 VAC)	Max. 60 A
Charging Current (120 VAC)	Max. 30 A
Charger plug type	CEE 2P+T
Charger Protection	Output short-circuit, Inverse polarity

⁽¹⁾ Maximum speed that can be achieved with the largest diameter tires available, on a flat surface and machine without attachments.

⁽²⁾ Tipping limit, when the machine is straight, with rear weights and boom lifted just off the ground. Weight of attachment included.

⁽³⁾ Maximum load that can be lifted just off the ground when the machine is straight and with rear weights. Weight of attachment is included.

⁽⁴⁾ The operation time of machine varies highly depending on the type of work it is performing. No hydraulic attachments used.

Note: Refer to the Operator's manual for the comprehensive load diagram.

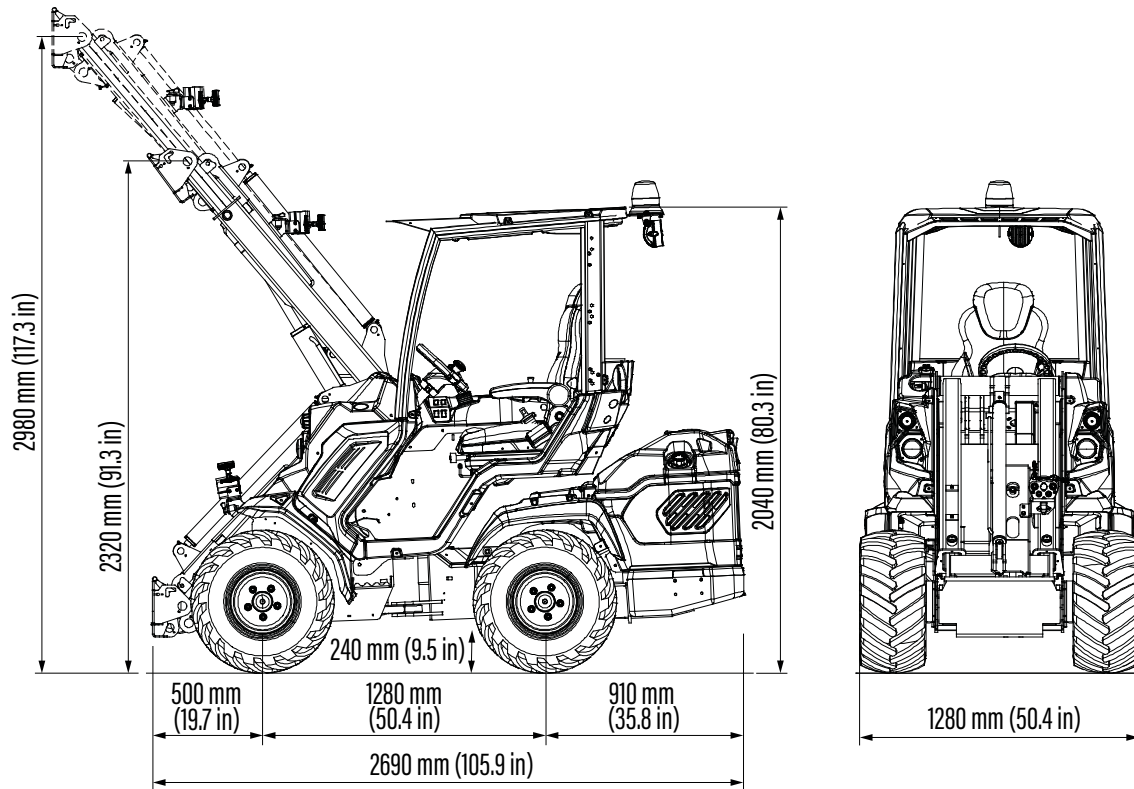





Tires size	Height	Width
23X8.50-12	2020 mm (79.5 in)	1070 mm (42.2 in)
23X10.50-12 ET-25	2020 mm (79.5 in)	1130 mm (44.5 in)
26X12.00-12 ET-50	2040 mm (80.3 in)	1280 mm (50.4 in)
27X8.50-15	2080 mm (81.9 in)	1070 mm (42.1 in)
27X10.50-15	2080 mm (81.9 in)	1150 mm (45.3 in)

FEATURES

- Twin Motors Single Ended Circuits
- LI-ION Battery
- Integrated Smart Battery Charger
- External fast charging station available
- Zero Emission
- Low Noise
- Braking Energy Recovery System
- Unbreakable Body Panels
- 4WD hydrostatic Direct Drive motors
- DBS (Dynamic Block System)
- Self-levelling double-H telescopic boom
- ACI with Multifunction joystick (22 functions) on Pack 1
- Self-locking multi-disk parking brake
- LCD graphic display with programmed service
- 2 front led working lights
- Ergonomic full adjustable suspension seat with armrests and seat belt
- Radial piston high efficiency and heavy duty wheel motors
- Hydraulic multiconnector
- ROPS-FOPS Level I

EZ SERIES: EZ8 LONG RANGE

<http://tiny.cc/EZ8seriesEN>**NEW****LONG RANGE**

 MAX LIFTING CAPACITY 1420 kg	 BATTERY CAPACITY 29,2 kWh	 SPEED 12 km/h	 FLOW RATE 35 l/min	 LIFT HEIGHT 2,98 m
--	---	---	--	--

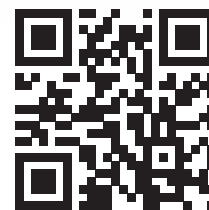
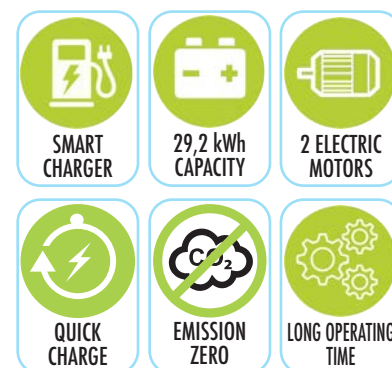
**LiION**
BATTERY

Model	EZ 8 Long Range
Transmission	Hydrostatic
Drive speed (max.) ⁽¹⁾	12 km/h (7.5 mph)
Aux. hydraulics oil flow	35 l/min (9.3 GPM)
Max. lifting height	2,98 m (117.3 in)
Tipping load, max. ⁽²⁾	1780 kg (3924 lbs)
Lifting capacity straight, max. ⁽³⁾	1420 kg (3130 lbs)
Breakout force / 50 cm	1700 kg (3748 lbs)
Pushing force (c)	2050 kgf (2050 kp)
Average ground pressure (w/standard tires)	958 kg/m ² (196 lbs/sqft)
Turning radius: inside/outside	825/2090 mm (32.5/82.3 in)
Standard tires (Tractor profile)	26X12.00-12 ET-50
Weight	1570 kg (3470 lbs)
Product Code	C963023
EZ8 Long Range Pack 1 (ACI with Multifunction joystick)	C963024

Electric system and battery

Battery type	LiFePO4
Battery capacity	29,2 kWh
Operation time ⁽⁴⁾ ECO MODE	6 h
Operation time ⁽⁴⁾ POWER MODE	4,5 h
Electric motors	2
Charging system	Integrated charger
Charger type	Sealed single-phase
Charger Input Voltage	110 - 230 ± 10% VAC
Charger Input Frequency	50 ÷ 60 Hz
Charger Absorbed Current	Max. 14 A
Charging Current (230 VAC)	Max. 60 A
Charging Current (120 VAC)	Max. 30 A
Charger plug type	CEE 2P+T
Charger Protection	Output short-circuit, Inverse polarity

⁽¹⁾ Maximum speed that can be achieved with the largest diameter tires available, on a flat surface and machine without attachments.

⁽²⁾ Tipping limit, when the machine is straight, with rear weights and boom lifted just off the ground. Weight of attachment included.

⁽³⁾ Maximum load that can be lifted just off the ground when the machine is straight and with rear weights. Weight of attachment is included.

⁽⁴⁾ The operation time of machine varies highly depending on the type of work it is performing. No hydraulic attachments used.

Note: Refer to the Operator's manual for the comprehensive load diagram.

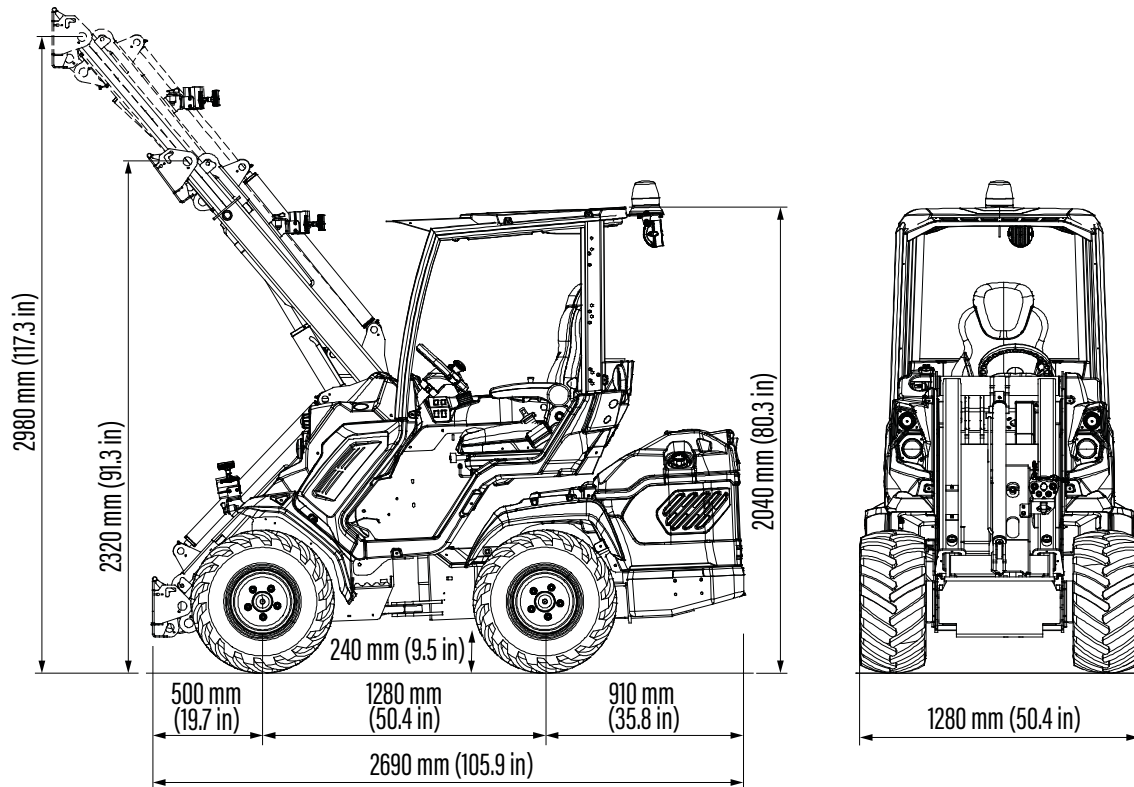

Tires size	Height	Width
23X8.50-12	2020 mm (79.5 in)	1070 mm (42.2 in)
23X10.50-12 ET-25	2020 mm (79.5 in)	1130 mm (44.5 in)
26X12.00-12 ET-50	2040 mm (80.3 in)	1280 mm (50.4 in)
27X8.50-15	2080 mm (81.9 in)	1070 mm (42.1 in)
27X10.50-15	2080 mm (81.9 in)	1150 mm (45.3 in)

FEATURES

- Twin Motors Single Ended Circuits
- LI-ION Battery
- Integrated Smart Battery Charger
- External fast charging station available
- Zero Emission
- Low Noise
- Braking Energy Recovery System
- 4WD hydrostatic Direct Drive motors
- Unbreakable Body Panels
- DBS (Dynamic Block System)
- Self-levelling double-H telescopic boom
- ACI with Multifunction joystick (22 functions) on Pack 1
- Self-locking multi-disk parking brake
- LCD graphic display with programmed service
- 2 front led working lights
- Ergonomic full adjustable suspension seat with armrests and seat belt
- Radial piston high efficiency and heavy duty wheel motors
- Hydraulic multiconnector
- ROPS-FOPS Level I

EZ 5 / EZ 8 - FAST CHARGING STATION



QUICK CHARGE



HIGH EFFICIENCY
SAVE ENERGY



BATTERY CARE



FLEXIBILITY



Models	95A	160A
Input Voltage	400 V ± 15 % - 50/60 Hz	
Nom. Phase Current	9 A	13 A
AC Plug	CEE 16A 400V 3P+T	
Battery Cable (mm ² /in ²)	25 / 0.04	35 / 0.06
Output Voltage	48V	
Output Current	95 A	160 A
Weight	50 kg (110 lbs)	
Product Code	C883809	C883808

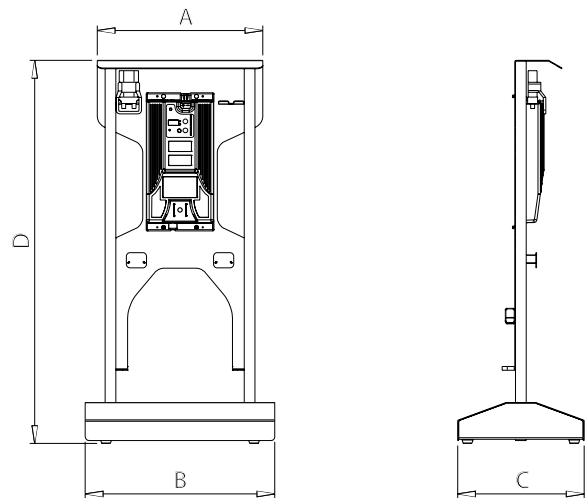

Dimensions				
	A	B	C	D
cm	65,5	75	50	151,5
in	25.5	29.5	19.5	60

FEATURES

- Suitable for EZ 5 and EZ 8
- Quick charge. 1 hour charging:
 - EZ 5 - 60% charge (with 95A Fast Charging Station)
 - EZ 8 - 50% charge (with 160A Fast Charging Station)
- CAN bus communication for lithium will ensure efficient and fast charging
- Peak Efficiency: 93%
- LCD display
- Forced air-cooling
- MultiOne coupling plate

EZ 7 / EZ8 - OPTIONS

Options	Code
2" Hitch receiver (not compatible with C883036)	C883062
Automatic coupling plate	C880015
Attachment coupling plate for rear mounting (not compatible with C883036)	C880031
Beacon light	C883039
Driver area cover	C880049
Fast charging station 160A (EZ8 only)	C883808
Fast charging station 95A (EZ8 only)	C883809
Flat face coupling kit	C880221
Floating boom valve	C883011
GPS tracker	C883075
Left protection bar for operator	C883030
Mirrors	C880081
Multifunction joystick with ACI	C883080
Polycarbonate back window (smart cabin)	C883035
Polycarbonate right side (smart cabin)	C883034
Polycarbonate windscreen (smart cabin)	C883000
Rear bull bar with side extensions (not compatible with C883062, C885014 and C880031)	C883036
Rear side weights 80 kg (40 kg + 40 kg) / 176 lbs (88 lbs + 88 lbs)	C883069
Rear side weights 160 kg (2x40 kg + 2x40 kg) / 352 lbs (2x88lbs+2x88lbs)	C883077
Rear weights 180 kg (90 kg + 90 kg) / 396 lbs (198lbs + 198 lbs)	C880054
Skid tires 27x10.50-15, set of 4	C884012
Skid tires 27x8.50-15, set of 4	C884011
Snow chains for wheels 23x10.50-12, set of 2	C880046
Snow chains for wheels 23x8.50-12, set of 2	C880041
Snow chains for wheels 26x12.00-12, set of 2	C880042
Snow chains for wheels 27x8.50-15, set of 2	C880045
Tie down bracket on wheel hub, set of 4	C883065
Torque divider	C883600
Tractor tires 23x10.50-12 ET-25, set of 4	C884007

EZ 7 / EZ8 - OPTIONS

Options	Code
Tractor tires 23x8.50-12, set of 4	C884005
Trailer coupling (not compatible with C883036)	C885014
Turf tires 23x10.50-12 ET-25, set of 4	C884008
Turf tires 23x8.50-12, set of 4	C884006
Turf tires 26x12.00-12 ET-50, set of 4	C884010
Warning & Safety lights for road travel (with mirrors)	C883814
Wheel spacer 10 mm (0.4 in), set of 4 (max. 1 pcs for wheel)	C880090
Wheel spacer 55 mm (2.2 in), set of 4 (max. 1 pcs for wheel)	C885010
ACI Upgrade	C090027

WHEELS



TRACTOR



SKID



TURF

Code	Size	Profile	Compatibility													
			1.1	2.3 EFI	5.2 K	5.3 K	6.3 IDS	7.2 K	EZ 5	EZ 7 - EZ 8	8.45 K	8.5 K	11.6 K - 11.9 K			
Wheel (Rim + Tire)																
C040034	18x9.50-8	Tractor	S													
C040035	18x9.50-8	Turf	C													
C040060	20x8.00-10	Tractor		S												
C040061	20x8.00-10	Turf		C												
C040049	23x8.50-12	Turf		C	C	C	C	C	C	C	C	C				
C040050	23x8.50-12	Tractor		C	S	C	S	C	C	C	C	C				
C040075	23x10.50-12 ET-25	Tractor			C	S	C	S	S	C	C					
C040076	23x10.50-12 ET-25	Turf			C	C	C	C	C	C	C	C				
C040056	26x12.00-12 ET-50	Tractor			C	C	C	C	C	C	S	S				
C040057	26x12.00-12 ET-50	Turf			C	C	C	C	C	C	C	C				
C040070	27x8.50-15	Skid			C	C	C	C	C	C	C	C				
C040072	27x10.50-15	Skid					C	C		C	C					
C040085	400/50-15 (31x15.50-15)	Turf														C
C040002	400/50-15 (31x15.50-15)	Tractor														C
C040036	400 / 50-15 ET-100 (31x15.50-15 ET-100)	Tractor													S	
C040087	400 / 50-15 ET-100 (31x15.50-15 ET-100)	Turf													C	
C040079	380/55-17	Tractor														S
C040095	380/55-17	Turf														C

S = standard ; C = compatible

OPTIONS

■ Standard
 ■ Optional
 ■ Not available



TELESCOPIC BOOM

Telescopic boom with double H frame for extra strength. It allows reaching considerable load heights, ensuring an excellent visibility of the load at any time.

1 Series	2 Series	5 Series	6 Series	7 Series	8 Series	11 Series	EZ Series



SELF-LEVELLING

This is an ideal device for lifting heavy loads safely. It is installed on the machine boom and keeps the load level, without the need to continuously correct the position with the joystick.

1 Series	2 Series	5 Series	6 Series	7 Series	8 Series	11 Series	EZ Series

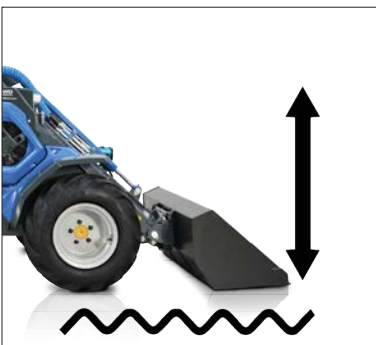

FLOATING BOOM VALVE

It allows to follow the contours of the land perfectly. Ideal for applications in agriculture and in the care of the green areas. Note: Self-levelling is disabled when the boom floating is turned on.

1 Series	2 Series	5 Series	6 Series	7 Series	8 Series	11 Series	EZ Series



FULLY ENCLOSED CAB WITH SOUND INSULATION LINEN

With weatherproof blue tinted glass, is the optimal solution for driver protection from cold, wet, wind and winter. The large door enables ease of access, whilst the side glass is hinged to open for ventilation. It's standard equipped with wiper. Heating system is suggested (come standard on 2 series cab).

1 Series	2 Series	5 Series	6 Series	7 Series	8 Series	11 Series	EZ Series



"SMART" CABIN

The most competitive solution for the operator who wants to improve working conditions thanks to a light cabin which limits the discomfort created by weathering.

1 Series	2 Series	5 Series	6 Series	7 Series	8 Series	11 Series	EZ Series

OPTIONS

■ Standard
 ■ Optional
 ■ Not available



HEATING

Heating with adjustable air flow and temperature.



HEATED SEAT

Ergonomic heated seat with armrests and seat belt. Ideal for cold climates, it significantly increases the comfort of the machine.

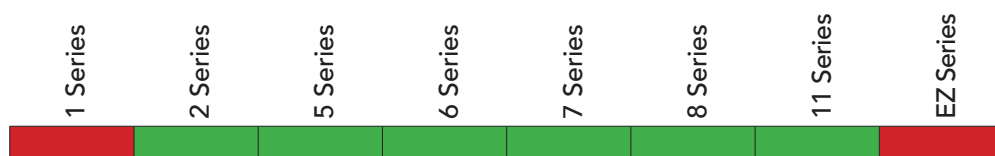

UNBREAKABLE BODY PANELS

The resistance and flexibility of the compound used let the panel absorb shocks, deform, and go back to its original shape.

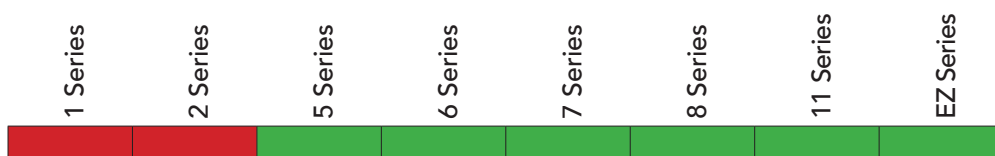

AIR CONDITIONING SYSTEM WITH HEATING FOR CAB

Air conditioning system from the roof of the cabin, with adjustable fan speed and electronic temperature control. Wide air outlets create a very comfortable ventilation system inside the cabin.



2 - 5

LEFT PROTECTION BAR FOR OPERATOR

It is placed on the left side of the machine to protect the operator from falling out of the vehicle. It can be locked and unlocked very quickly thanks to a special mechanism.



6 - 7 - 8 - 11 - EZ



OPTIONS

Standard Optional Not available



WARNING AND SAFETY LIGHTS FOR ROAD TRAVEL (W/ MIRRORS)

Front and rear lights, brake lights, turning lights, beacon, mirrors. In certain countries this equipment enables road traffic registration – requirements vary in different countries, please consult your local MultiOne distributor.

1 Series	2 Series	5 Series	6 Series	7 Series	8 Series	11 Series	EZ Series
Not available	Optional	Optional	Optional	Optional	Optional	Optional	Optional

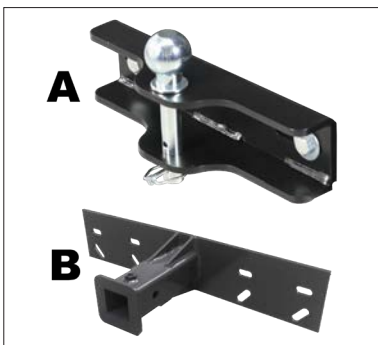

TRAILER COUPLING / 2" HITCH RECEIVER

Two type of trailer coupling: A) rear tow hook with double connection: with tow ball (car type) and tow pin (agricultural type). B) 2" Hitch receiver. Not compatible with 2.3 EFI. Can be used also with rear weights.

1 Series	2 Series	5 Series	6 Series	7 Series	8 Series	11 Series	EZ Series
Not available	Optional	Optional	Optional	Optional	Optional	Optional	Optional



REAR WEIGHTS 220 KG + 220 KG (485 LBS + 485 LBS)

Rear weights are used to increase the lifting capacity of the machine. They are to be mounted on the rear side of the machine.

1 Series	2 Series	5 Series	6 Series	7 Series	8 Series	11 Series	EZ Series
Not available	Not available	Not available	Not available	Not available	Not available	Optional	Not available



REAR WEIGHTS 90 KG + 90 KG (198 LBS + 198 LBS)

Rear weights are used to increase the lifting capacity of the machine. They are to be mounted on the rear of the machine.

1 Series	2 Series	5 Series	6 Series	7 Series	8 Series	11 Series	EZ Series
Not available	Optional	Optional	Optional	Optional	Optional	Optional	Optional



REAR SIDE WEIGHTS 40 KG + 40 KG (88 LBS + 88 LBS)

Rear side weights are used to increase the lifting capacity of the machine. It's possible to mount them also with other rear weights mounted. Two kit (80 kg per side, 160 kg total) can be mounted.

1 Series	2 Series	5 Series	6 Series	7 Series	8 Series	11 Series	EZ Series
Not available	Not available	Optional	Optional	Optional	Optional	Optional	Optional

OPTIONS

■ Standard
 ■ Optional
 ■ Not available



DYNAMIC BLOCK SYSTEM

The DBS diverts oil flow between the left & right side hydraulic wheel motors: the hydraulic oil flows in parallel between the hydraulic wheel motors on each side operating similar to a differential lock.

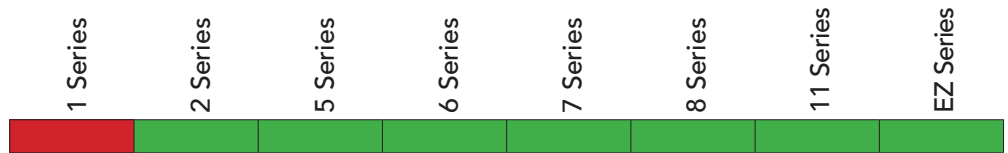

TORQUE DIVIDER

It evenly distributes hydraulic oil between the front right and front left side hydraulic motors, improving traction on slippery and uneven surfaces.



HYDRAULIC MULTICONNECTOR

It is a innovative coupling system for front attachments that allow the connection of the hydraulic lines in a few seconds without stress.

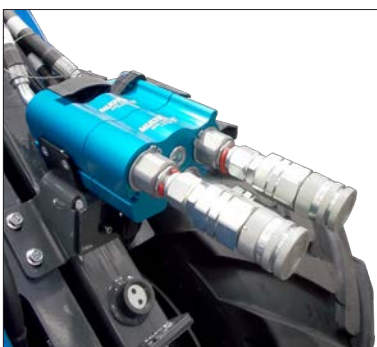

FLAT FACE COUPLING KIT

Adaptor to be put on the multiconnector, in order to connect standard flat face connections.



REAR HYDRAULIC OUTLETS

They are used to mount on the rear side attachments that need hydraulic supply. The rear outlets are controlled by the control panel.



OPTIONS

■ Standard
 ■ Optional
 ■ Not available

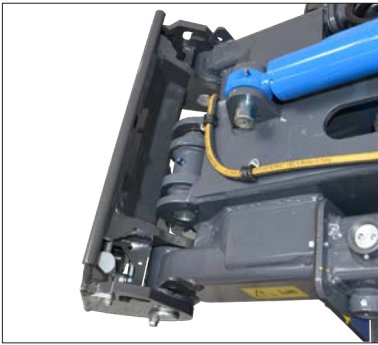

AUTOMATIC LOCKING/UNLOCKING PLATE

On the automatic attachment plate the locking pins move hydraulically and are operated from cockpit. This way the driver can stay on the seat when coupling and disconnecting non-hydraulic attachments.

1 Series	2 Series	5 Series	6 Series	7 Series	8 Series	11 Series	EZ Series



ATTACHMENT COUPLING PLATE FOR REAR MOUNTING

It is used to assemble attachments on the rear of the machine.

1 Series	2 Series	5 Series	6 Series	7 Series	8 Series	11 Series	EZ Series



REAR 12V ELECTRIC SOCKET

12 Volt rear electric socket to connect the attachments.

1 Series	2 Series	5 Series	6 Series	7 Series	8 Series	11 Series	EZ Series



ENGINE BLOCK HEATER

It is an ideal device for cold temperatures. The system keeps the engine at an optimal temperature for easy starting with very cold climates. 220V or 110V available.

1 Series	2 Series	5 Series	6 Series	7 Series	8 Series	11 Series	EZ Series



WHEEL SPACER KIT

Wheel spacers are used to make the machine wider and increase its stability.

1 Series	2 Series	5 Series	6 Series	7 Series	8 Series	11 Series	EZ Series

OPTIONS

■ Standard
 ■ Optional
 ■ Not available



DRIVER AREA COVER

Covers the machine interior, protects against rain, snow, etc.

1 Series	2 Series	5 Series	6 Series	7 Series	8 Series	11 Series	EZ Series

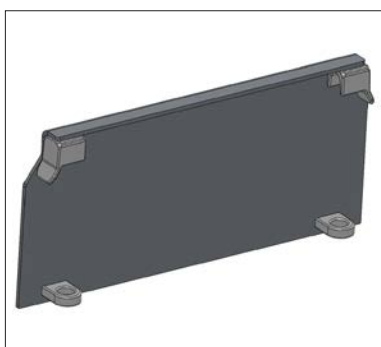

ATTACHMENT COUPLING PLATE

Plate to be welded on the customer's attachment to make it suitable for MultiOne mini loader. To be checked (at customer charge): - applicable laws and safety requirements - machine and circuits interface.

CODE: C880233 (6 mm)

CODE: C880236 (12 mm)

1 Series	2 Series	5 Series	6 Series	7 Series	8 Series	11 Series	EZ Series

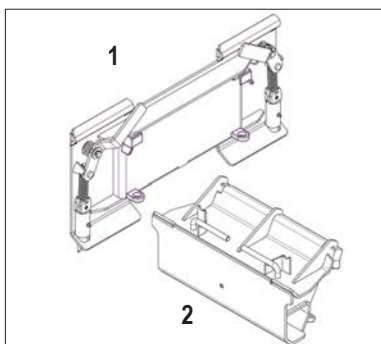

SKID-STEER ATTACHMENT ADAPTER PLATE

Coupling adapter suitable to mount skid steer attachments on MultiOne mini loader.

1 - CODE: C890023 - MT skid steer attachment adapter plate

2 - CODE: C880230 - Mini skid steer attachment adapter plate

1 Series	2 Series	5 Series	6 Series	7 Series	8 Series	11 Series	EZ Series



BACKUP WARNING BEEPER

It help to keep everyone safer during MultiOne machine operation.

1 Series	2 Series	5 Series	6 Series	7 Series	8 Series	11 Series	EZ Series



BEACON LIGHT

Orange beacon light mounted on the top of the cab's roof.

1 Series	2 Series	5 Series	6 Series	7 Series	8 Series	11 Series	EZ Series

OPTIONS

■ Standard
 ■ Optional
 ■ Not available



MULTIFUNCTION JOYSTICK

The multi-function electronic joystick allows an easy and precise control of the boom and attachments.

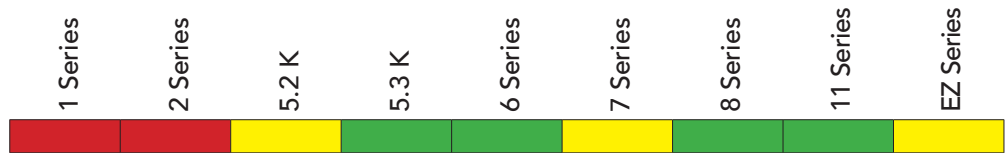

ACI (ATTACHMENTS CONTROL INTERFACE)

ACI system allows the driver to control the attachments movements without the need for separate control boxes, cables or additional wiring. The connection to the attachments is made by a 7-poles socket.



RUBBER TRACKS

Track drive grant maximum stability & traction, with minimal ground damage and low ground bearing pressure. The large contact area under the tracks reduces pressure, minimises ground damage and avoids sinking into soft soil & creating ruts. (Kit weight 750 kg/1655 lbs)



HI FLOW

It's a additional pump that increases the outlets oil flow.



ONE DRIVE

OneDrive is a brand new transmission system with a performance output over 30% higher than standard circuit.



OPTIONS

■ Standard
 ■ Optional
 ■ Not available

CRUISE CONTROL

CRUISE CONTROL

OneDrive hydrostatic transmission allows to set and easily change speed for outstanding control. The machine speed is rock-solid.

1 Series	2 Series	5 Series	6 Series	7 Series	8 Series	11 Series	EZ Series



REAR BULL BAR

It protects the rear side of the machine in case of shocks. With side extensions from 7 series on. Not compatible with rear weights, trailer coupling and rear coupling plate.

1 Series	2 Series	5 Series	6 Series	7 Series	8 Series	11 Series	EZ Series



SNOW CHAINS

MultiOne snow chains improve traction on snow or ice (Set of 2).

1 Series	2 Series	5 Series	6 Series	7 Series	8 Series	11 Series	EZ Series



TIE DOWN BRACKET ON WHEEL HUB

The tie down brackets mounted on wheel hub makes easier to tie down the machine on a trailer.

1 Series	2 Series	5 Series	6 Series	7 Series	8 Series	11 Series	EZ Series



ADDITIONAL WORKING LIGHTS

Auxiliary working lights for more visibility. Two front and one rear. Available led or halogen version.

1 Series	2 Series	5 Series	6 Series	7 Series	8 Series	11 Series	EZ Series

GENERAL BUCKET

<http://tiny.cc/generalbucket>



FEATURES & BENEFITS

- All-round bucket, suitable for almost every shovelling job
- Efficient design and excellent visibility to the edge of the bucket
- Heavy Duty construction with slide wear bars on the bottom
- High breakout force
- Strong cutting edge made of high tensile, abrasion resistant wear steel, designed for bolt-on teeth



The MultiOne bucket design enables good visibility to the cutting edge, making loading, grading, and dumping more efficient. Length of the bucket has been optimized in order to give best possible breakout force. Heavy duty steel construction includes reinforcement plates inside, slide wear bars on the bottom of the bucket, and the cutting edge is designed for bolt-on teeth.

Model	Volume*	Width	Length	Height	Weight	Teeth	Code
80	85 l (3 ft ³)	80 cm (31.5 in)	63 cm (24.8 in)	47 cm (18.5 in)	40 kg (88 lbs)	4	C890001

(* verify the lifting capacity of the machine)

Accessories

	Weight	Code
Tooth	1,7 kg (3.7 lbs)	C890007

Compatibility	1.1	2.3	4.2	5.2	5.3	6.3	7.2	8.4	8.5	11.6	11.9	EZ5	EZ7 EZ8
Model													
80													

Very compatible

Compatible

Not compatible



NEW GENERAL BUCKET

<http://tiny.cc/newgeneralbucket>

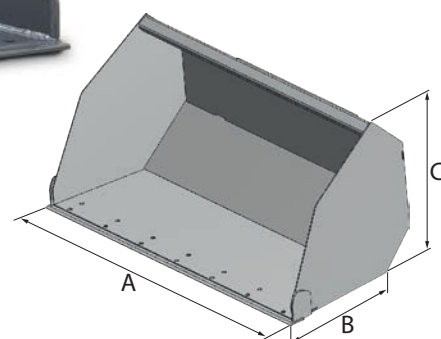
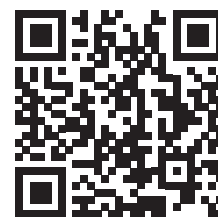

FEATURES & BENEFITS

- New efficient design increases volume and visibility
- Bolt-on Teeth and Cutting edge available
- Heavy duty (HD) models available for hard works

The new design of the MultiOne bucket increases the volume and enables good visibility. The inside of the bucket is completely plain and the sides open forward in slight angle which guarantees easy and complete filling and emptying of all kinds of materials. There are narrow holes at the upper end of the bucket which improve visibility and prevent stones from falling towards the operator. The special design allows to stack the buckets one inside the other saving storage space (until 6 on a pallet). Available with cutting edge and teeth.

Model	Volume*	Width (A)	Length (B)	Height (C)	Weight	Teeth	Code
100	205 l (7.2 ft ³)	100 cm (39.4 in)	58 cm (22.8 in)	59 cm (23.2 in)	66 kg (146 lbs)	5	C890031
115	238 l (8.4 ft ³)	115 cm (45.3 in)	58 cm (22.8 in)	59 cm (23.2 in)	74 kg (163 lbs)	6	C890032
130	272 l (9.6 ft ³)	130 cm (51.2 in)	58 cm (22.8 in)	59 cm (23.2 in)	82 kg (181 lbs)	7	C890033
130HD	272 l (9.6 ft ³)	130 cm (51.2 in)	58 cm (22.8 in)	59 cm (23.2 in)	130 kg (287 lbs)	7	C890034
150HD	316 l (11.2 ft ³)	150 cm (59 in)	58 cm (22.8 in)	59 cm (23.2 in)	146 kg (322 lbs)	8	C890035
180HD	383 l (13.5 ft ³)	180 cm (71 in)	58 cm (22.8 in)	59 cm (23.2 in)	170 kg (375 lbs)	10	C890036

(*) verify the lifting capacity of the machine

Accessories						Weight	Code
Tooth						1,7 kg (3.7 lbs)	C890007

	100	115	130 /130HD	150HD	180HD
Bolt-on cutting edge					
Code	C890037	C890038	C890039	C890040	C890041

Compatibility	1.1	2.3	4.2	5.2	5.3	6.3	7.2	8.4	8.5	11.6	11.9	EZ5	EZ7 EZ8
Model													
100	Green	Green	Green	Green	Green	Green	Green	Green	Green	Green	Green	Green	Green
115	Yellow	Green	Green	Green	Green	Green	Green	Green	Green	Green	Green	Green	Green
130 / 130HD	Red	Yellow	Green	Green	Green	Green	Green	Green	Green	Green	Green	Green	Green
150HD	Red	Green	Green	Green	Green	Green	Green	Green	Green	Green	Green	Green	Green
180HD	Red	Green	Green	Green	Green	Green	Green	Green	Green	Green	Green	Green	Green

Very compatible (Green) Compatible (Yellow) Not compatible (Red)



LEVELLING BUCKET

<http://tiny.cc/levellingbucket>



FEATURES & BENEFITS

- Excellent visibility to the edge of the bucket
- Sharp back edge enables exact levelling when driving backward
- Heavy Duty construction
- Strong cutting edge made of high tensile, abrasion resistant wear steel

The MultiOne levelling bucket has a sharp back edge which makes levelling easy when driving backward. Low rise design and a long bottom gives excellent visibility to the front edge of the bucket. This also makes levelling easier. The levelling bucket is strong and completely plain inside, which makes the filling and emptying easy. It is an ideal tool to levelling gravel and soils for landscaping and gardening projects.

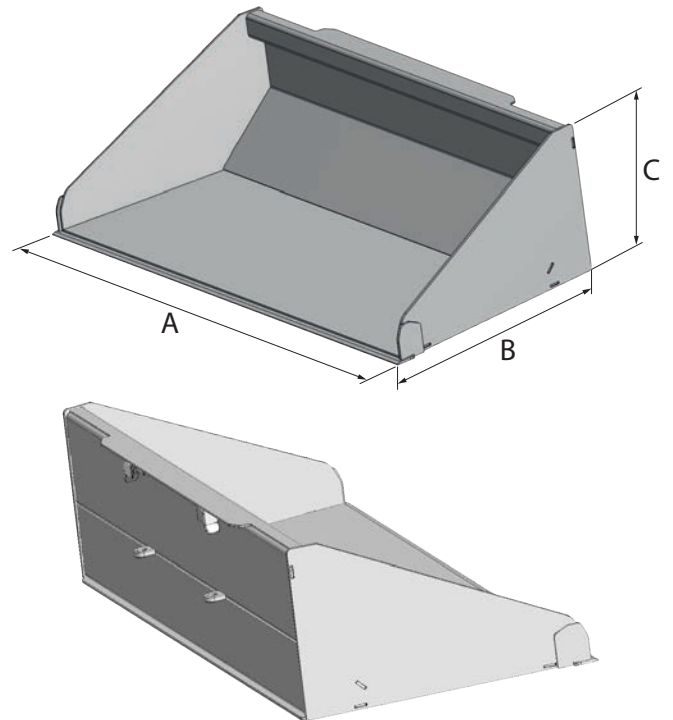

Model	Volume*	Width (A)	Length (B)	Height (C)	Weight	Code
140	244 l (8.6 ft ³)	141 cm (55.5 in)	79 cm (31.1 in)	46 cm (18.1 in)	150 kg (331 lbs)	C890042
160	282 l (10 ft ³)	161 cm (63.4 in)	79 cm (31.1 in)	46 cm (18.1 in)	170 kg (375 lbs)	C890043

(* verify the lifting capacity of the machine)

Compatibility	1.1	2.3	4.2	5.2	5.3	6.3	7.2	8.4	8.5	11.6	11.9	EZ5	EZ7 EZ8
Model													
140													
160													

Very compatible
 Compatible
 Not compatible



COMBO BUCKET

<http://tiny.cc/combobucket>



FEATURES & BENEFITS

- Heavy duty construction
- Two cylinders with hydraulic locking valve for load holding
- Increased dumping height
- Multiple functions: digging, dozing, grading, grappling, and dumping
- Cutting edge designed for bolt on teeth

This multi-purpose bucket can be used for demolition, landscaping, and general construction works. When used as a grapple, the dual cylinders, equipped with load holding valves, provide a secure clamping force to pick stones, tree stumps etc... The bucket can be opened for fine grading. Another benefit of the opening bottom is that the bucket can be emptied at a higher level by opening the bottom instead of tipping the bucket edge down. Heavy duty steel construction includes a cutting edge that is designed for bolt-on teeth.



Model	Volume*	Width	Length	Height	Opening Angle	Weight	Teeth	Code
110	260 l (9.2 ft ³)	110 cm (43.3 in)	81 cm (32 in)	65 cm (25.6 in)	75°	149 kg (329 lbs)	6	C890075
130	310 l (11 ft ³)	130 cm (51.2 in)	81 cm (32 in)	65 cm (25.6 in)	75°	182 kg (401 lbs)	8	C890076
160	410 l (14.5 ft ³)	160 cm (63 in)	81 cm (32 in)	65 cm (25.6 in)	75°	206 kg (454 lbs)	9	C890078

(* verify the lifting capacity of the machine)

Accessories		Weight	Code
Tooth		1,7 kg (3.7 lbs)	C890007

Compatibility	1.1	2.3	4.2	5.2	5.3	6.3	7.2	8.4	8.5	11.6	11.9	EZ5	EZ7 EZ8
Model													
110													
130													
160													

Very compatible
 Compatible
 Not compatible



GRAPPLE BUCKET

<http://tiny.cc/grapplebucket>

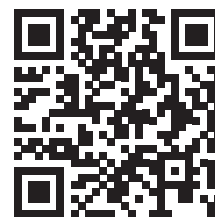

FEATURES & BENEFITS

- Versatile bucket for handling of loose materials
- Heavy duty construction
- Easily controlled hydraulic grapple

Grapple bucket combines a normal bucket and a grapple and is therefore suitable for a multitude of jobs.

This bucket is ideally designed to dig and grab difficult material. Heavy duty steel bucket design, combined with the center mounted hydraulic cylinder and efficiently designed grapple teeth, enable this bucket to do multiple jobs, from loading and grading loose soils and materials, to grabbing and loading awkward materials. It can be used for transporting and loading of branches, wood chips, compost, straw, manure, construction waste etc. It can also be used as a normal bucket with the grapple in the upright position.



Model	Width	Length	Height	Opening Angle	Weight	Code
110	110 cm (43.3 in)	67 cm (26.4 in)	47 cm (18.5 in)	84°	119 kg (262 lbs)	C890065
130	130 cm (51.2 in)	67 cm (26.4 in)	47 cm (18.5 in)	84°	134 kg (295 lbs)	C890066

Compatibility	1.1	2.3	4.2	5.2	5.3	6.3	7.2	8.4	8.5	11.6	11.9	EZ5	EZ7 EZ8
Model													
110													
130													

Very compatible
 Compatible
 Not compatible



DEMOLITION GRAPPLE BUCKET

<http://tiny.cc/grapplebucket>

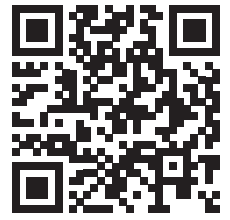

FEATURES & BENEFITS

- Move hard to handle materials easily
- Two hydraulic grapples easy to operate
- Handles bulky, uneven loads securely

This bucket is designed to handle bulky, irregularly shaped objects found in demolition, industries, construction, and recycling. Ideal for trunks, large rocks, bushes, industrial and demolition scraps, and recycling debris. The two grapples are driven by two powerful hydraulic cylinders, which allow them to adapt optimally to the load to be lifted while maintaining a solid and secure grip.

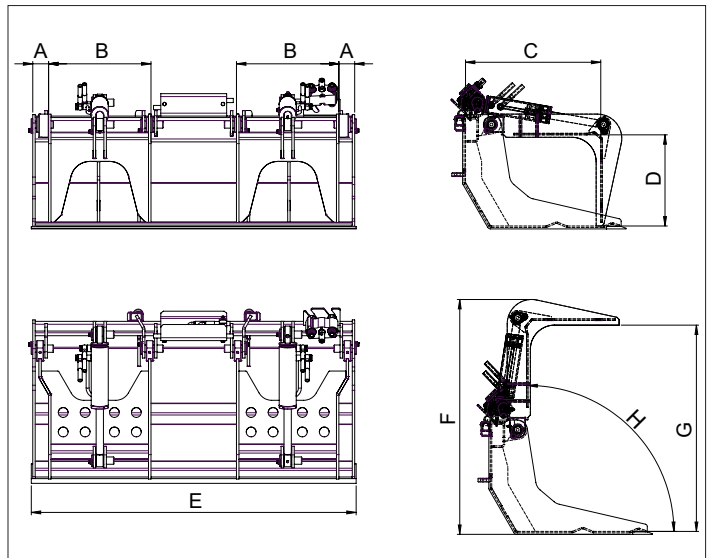

	Dimensions (cm/in)							
	A	B	C	D	E	F	G	H
Mod. 130	6,5/2.6	42/16.5	55,5/21.8	37/14.7	133/52.5	96/38	85/33	90°
Mod. 150	6,5/2.6	42/16.5	55,5/21.8	37/14.7	153/60	96/38	85/33	90°

Model	Width	Weight	Code
130	130 cm (51.2 in)	200 kg (441 lbs)	C890067
150	150 cm (59 in)	220 kg (485 lbs)	C890068

Compatibility	1.1	2.3	4.2	5.2	5.3	6.3	7.2	8.4	8.5	11.6	11.9	EZ5	EZ7 EZ8
Model													
130													
150													

Very compatible
 Compatible
 Not compatible



NEW LIGHT MATERIAL BUCKET

<http://tiny.cc/newlightmaterialbucket>



FEATURES & BENEFITS

- New efficient design increases volume and visibility
- Design to improve transport optimization
- Great resistance

The new design of the MultiOne bucket increases the volume and enables good visibility. The inside of the bucket is completely plain and the sides open forward in slight angle which guarantees easy and complete filling and emptying of all kinds of materials. The special design allows to stack the buckets one inside the other saving storage space (until 6 on a pallet).

The bottom of a light material bucket is considerably longer and the sides are higher than on a general bucket, which speeds up the work a lot. High back of the bucket prevents material from falling over the rear edge and guarantees high volume.



Model	Volume*	Width	Length	Height	Weight	Code
100	390 l (13.8 ft ³)	101 cm (39.7 in)	92 cm (36.2 in)	77,5 cm (30.5 in)	94 kg (207 lbs)	C890370
115	455 l (16 ft ³)	116 cm (45.6 in)	92 cm (36.2 in)	77,5 cm (30.5 in)	108 kg (238 lbs)	C890371
130	520 l (18.4 ft ³)	131 cm (51.5 in)	92 cm (36.2 in)	77,5 cm (30.5 in)	117 kg (256 lbs)	C890372
150	605 l (21.4 ft ³)	151 cm (59.4 in)	92 cm (36.2 in)	77,5 cm (30.5 in)	134 kg (295 lbs)	C890373
180	735 l (25.9 ft ³)	181 cm (71.2 in)	92 cm (36.2 in)	77,5 cm (30.5 in)	156 kg (344 lbs)	C890374

(*) verify the lifting capacity of the machine

Compatibility	1.1	2.3	4.2	5.2	5.3	6.3	7.2	8.4	8.5	11.6	11.9	EZ5	EZ7 EZ8
Model													
100													
115													
130													
150													
180													

Very compatible
 Compatible
 Not compatible



HIGH TIP BUCKET

<http://tiny.cc/hightipbucket>

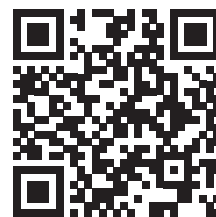

FEATURES & BENEFITS

- Hydraulic operated
- Increased dump height (+ 60 cm / 24 in)
- Excellent volume

High tip bucket is the right choice when you need to reach higher and longer. The bucket is equipped with two hydraulic cylinders that push and tip the bucket over its front edge, which gives considerably more tipping height than with a normal bucket. Increase the dump height of the machine by almost 60 cm (24 in) using the high tip bucket. This increased reach enables loading high-side trucks without the need of a ramp. The bucket is an ideal tool for snow removal, loading of wood chips and for loading works on recycling plants etc. The bucket is available with a flat cutting edge.



Model	Volume*	Width	Length	Height	Weight	Code
100	210 l (8.1 ft ³)	100 cm (39.4 in)	86 cm (33.8 in)	61 cm (24 in)	154 kg (339 lbs)	C890090
130	280 l (9.9 ft ³)	130 cm (51.2 in)	86 cm (33.8 in)	61 cm (24 in)	174 kg (384 lbs)	C890092
150	320 l (11.3 ft ³)	150 cm (59 in)	86 cm (33.8 in)	61 cm (24 in)	188 kg (414 lbs)	C890093
180	380 l (13.4 ft ³)	180 cm (71 in)	86 cm (33.8 in)	61 cm (24 in)	208 kg (460 lbs)	C890094

(*) verify the lifting capacity of the machine

Compatibility	1.1	2.3	4.2	5.2	5.3	6.3	7.2	8.4	8.5	11.6	11.9	EZ5	EZ7 EZ8
Model													
100	Very compatible	Very compatible	Very compatible	Very compatible	Very compatible	Very compatible	Very compatible	Very compatible	Very compatible	Very compatible	Very compatible	Very compatible	Very compatible
130	Very compatible	Very compatible	Very compatible	Very compatible	Very compatible	Very compatible	Very compatible	Very compatible	Very compatible	Very compatible	Very compatible	Very compatible	Very compatible
150	Very compatible	Compatible	Very compatible	Very compatible	Very compatible	Very compatible	Very compatible	Very compatible	Very compatible	Very compatible	Very compatible	Very compatible	Very compatible
180	Very compatible	Compatible	Very compatible	Very compatible	Very compatible	Very compatible	Very compatible	Very compatible	Very compatible	Very compatible	Very compatible	Very compatible	Very compatible

(*) C890025 adapter required



PALLET FORK

<http://tiny.cc/palletfork>

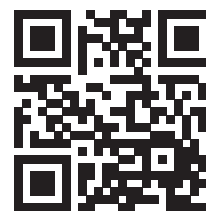

FEATURES & BENEFITS

- **Must-have attachment**
- **Heavy duty construction**
- **Easily adjustable forks width**
- **Useful attachment on construction sites, farms, as well as on the company's yards doing material handling jobs**

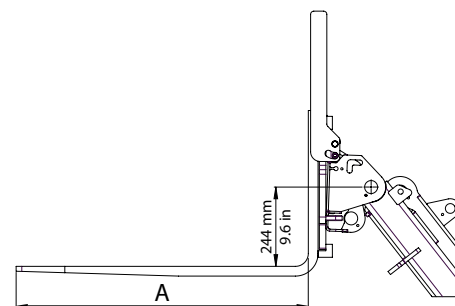

The pallet fork enables safe and quick handling of multiple sized pallets. The forks are forged from high strength steel, and are available in several lengths based on model size. The fork frame is designed to allow the width of the forks to be easily adjusted by as much as 1 m / 39 in (70 cm / 27.6 in on C895120). Optional bolt on back stop provides additional safety. MultiOne is an excellent machine for load handling thanks to the precise steering and drive control. Compared with a conventional forklift truck MultiOne is superior when working outdoors and on uneven terrains, on all seasons.

Model	Forks Length (A)	Lifting Capacity ³	Width	Weight	Code
80 (frame + forks)	80 cm (31.5 in)	250 kg (551 lbs)	70 cm (27,6 in)	38 kg (84 lbs)	C895120
Frame HD (without forks) ¹	/	up to 2000 kg (4408 lbs)	100 cm (39,4 in)	43 kg (95 lbs)	C890335
90 (forks pair) ²	90 cm (35.4 in)	1000 kg (2204 lbs)	/	54 kg (119 lbs)	C890331
110 (forks pair) ²	110 cm (43.3 in)	1200 kg (2646 lbs)	/	68 kg (150 lbs)	C890332
120 (forks pair) ²	120 cm (47.3 in)	2000 kg (4408 lbs)	/	104 kg (230 lbs)	C890333

(¹) C890331 or C890332 or C890333 required - (²) C890335 required - (³) verify the lifting capacity of the machine

Optional (may be required by law)			
Back stop		8 kg (17 lbs)	C890312

Compatibility	1.1	2.3	4.2	5.2	5.3	6.3	7.2	8.4	8.5	11.6	11.9	EZ5	EZ7 EZ8
Model													
80	Green	Yellow	Red	Red	Red	Red	Red	Red	Red	Red	Red	Red	Red
90	Red	Green	Green	Green	Green	Green	Green	Yellow	Yellow	Yellow	Yellow	Green	Green
110	Red	Red	Green	Green	Green	Green	Green	Yellow	Yellow	Yellow	Yellow	Green	Green
120	Red	Red	Green	Green	Green	Green	Green	Green	Green	Green	Green	Green	Green

Very compatible (Green) Compatible (Yellow) Not compatible (Red)



PALLET FORK HYDRAULIC CLAMP

<http://tiny.cc/hydraulicclamp>



FEATURES & BENEFITS

- A unique option for the pallet fork system
- Secures awkward loads to the forks
- Basic attachment for fencing and forest work
- Grabbing and transporting of stones and similar objects also possible

The hydraulic clamp attaches to the pallet fork frame, changing the pallet fork to a versatile grapple system. The hydraulically operated grapple secures awkward loads like logs, poles, large tubes, and more.

The grab is equipped with a powerful hydraulic cylinder. The hydraulic clamp assembly requires either a pallet fork (C890335 frame + forks - not included with the hydraulic clamp).

The back stop (C890312) can't be installed with the hydraulic clamp.



Model	Min. diameter to grab	Max. diameter to grab	Opening Angle	Weight	Code
Pallet Fork Hydraulic Clamp	40 cm (15.7 in)	90 cm (35.4 in)	90°	46 kg (102 lbs)	C890585

Compatibility	1.1	2.3	4.2	5.2	5.3	6.3	7.2	8.4	8.5	11.6	11.9	EZ5	EZ7 EZ8



BIG BAG LIFTER

<http://tiny.cc/bigbaglifter>



FEATURES & BENEFITS

- Simple and efficient
- Rounded anti-swing side bars

This attachment enables safe and efficient handling of the oversized product bags containing fertilizer, corn, wood pellets, briquettes, and other granular products.

The anti-swing side bars increase operating safety without damaging the bags.

The heavy-duty construction has been widely tested, proving to be strong, reliable and durable.



Model	Lifting Capacity*	Max Width	Lift Hook Height	Weight	Code
Big Bag Lifter	1200 kg (2645 lbs)	100 cm (39.4 in)	133 cm (52.4 in)	49 kg (108 lbs)	C890713

(* verify the lifting capacity of the machine)

Compatibility	1.1	2.3	4.2	5.2	5.3	6.3	7.2	8.4	8.5	11.6	11.9	EZ5	EZ7 EZ8
	Very compatible			Compatible				Not compatible					



JIB CRANE, ONE-PIECE OR TELESCOPIC

<http://tiny.cc/jibcrane>

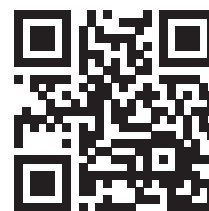

FEATURES & BENEFITS

- Useful for great outreach and high-lift
- Safety hook included
- Compact for good visibility
- Versatile lifting attachment for various load handling jobs

The MultiOne Jib Crane provides additional reach for lifting operations. The jib crane is available in either a one piece design or a hydraulically adjustable telescopic design. Each of these designs includes a heavy duty safety hook.

The one-piece jib crane is equipped with two connecting points, one at the tip of the boom and one 500 mm lower.

The telescopic jib crane allows for keeping the load close to the machine during handling and then extending it for placement. The steplessly extending and retracting boom allows lifting to places that would otherwise be very hard to reach. Compact design with telescoping cylinder inside the boom and durable wear pads on the outer boom, makes work safe and easy.

The maximum lifting load varies according to the machine on which it is installed.



Model	Length	Structural capacity*	Weight	Code
One-piece	250 cm (98.4 in)	200 kg (440 lbs)	41 kg (90.4 lbs)	C890710
Telescopic	110+60 cm (43.3+23.6 in)	500 kg (1100 lbs)	85 kg (187.4 lbs)	C890712

(* verify the lifting capacity of the machine)

Compatibility	1.1	2.3	4.2	5.2	5.3	6.3	7.2	8.4	8.5	11.6	11.9	EZ5	EZ7 EZ8
Model													
One-piece													
Telescopic													

Very compatible
 Compatible
 Not compatible



LIFTING TROLLEY

<http://tiny.cc/liftingtrolley>



FEATURES & BENEFITS

- Designed to safely lift and handle heavier loads
- Made from heavy duty steel for reliability
- Excellent fork visibility
- Forks width adjustable

The MultiOne lifting trolley increases the lifting capacity of smaller models of MultiOne machines.

The lifting trolley is ideal for lifting and handling heavy pallets, oversized material bags, and other heavy materials. This unit can also be used to load and unload trucks and trailers.

The lifting trolley is equipped with foam filled rough terrain tires to allow all terrain materials transport. The fork width is manually adjustable to adapt to different pallet sizes.

Note: the floating boom valve on the machine is suggested.



Model	Forks Length	Lifting Capacity*	Max Lifting Height	Height	Width	Weight	Code
Lifting Trolley	90 cm (35.4 in)	1000 kg (2204 lbs)	170 cm (67 in)	212 cm (83.5 in)	130 cm (51.2 in)	216 kg (476 lbs)	C890481

(*) verify the lifting capacity of the machine

Compatibility	1.1	2.3	4.2	5.2	5.3	6.3	7.2	8.4	8.5	11.6	11.9	EZ5	EZ7 EZ8
	Very compatible				Compatible				Not compatible				



PALLET FORK WITH SIDE SHIFT

<http://tiny.cc/palletforkwithsideshift>

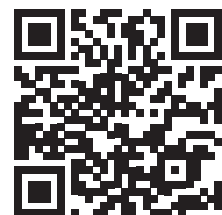

FEATURES & BENEFITS

- Safely controlled side shift from the driver's position
- Designed to work in tight areas or along narrow aisles
- Different sizes of forks available
- Back stop as standard

Hydraulically side shifting the forks enables easier and safer handling and loading of a wide variety of pallet sizes.

The forks can be moved to the left or to the right, making it possible to shift the load to the side of the machine - closer to a wall for example. This function can be operated from the driver's seat. The fork width is manually adjustable to adapt to different pallet sizes.

Pallet fork is equipped as standard with a back stop which enables handling of larger loads and protects the driver from falling objects. Different sizes of forks are available.

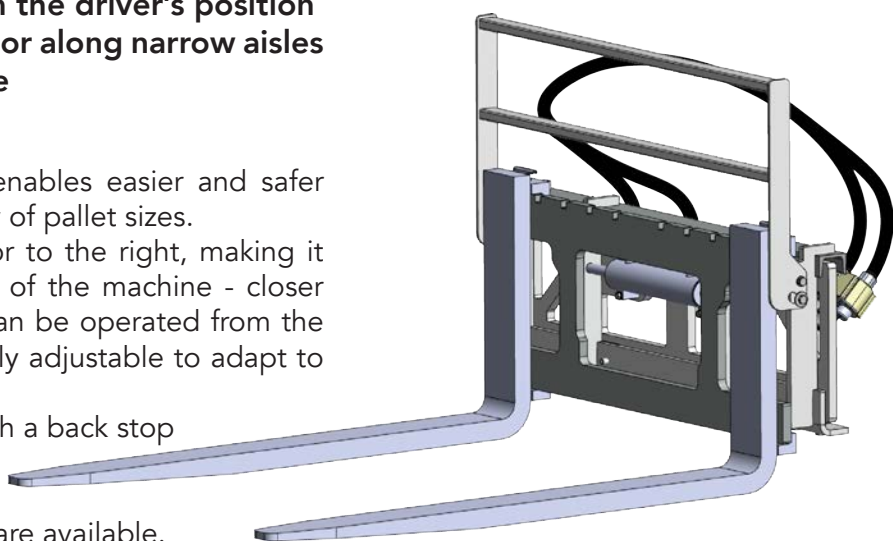

Model	Forks Length	Lifting Capacity ³	Side Shift	Weight	Code
Frame (without forks) ¹	/	/	8,5 cm (3.4 in) to the left 8,5 cm (3.4 in) to the right	96 kg (212 lbs)	C890316
90 (forks pair) ²	90 cm (35.4 in)	1000 kg (2204 lbs)		54 kg (119 lbs)	C890331
110 (forks pair) ²	110 cm (43.3 in)	1200 kg (2646 lbs)		68 kg (150 lbs)	C890332
120 (forks pair) ²	120 cm (47.3 in)	2000 kg (4408 lbs)		104 kg (230 lbs)	C890333

(¹) C890331 or C890332 or C890333 required - (²) C890316 required - (³) verify the lifting capacity of the machine

Compatibility	1.1	2.3	4.2	5.2	5.3	6.3	7.2	8.4	8.5	11.6	11.9	EZ5	EZ7 EZ8
Model													
90	Very compatible	Compatible	Compatible	Compatible	Compatible	Compatible	Compatible	Compatible	Compatible	Compatible	Compatible	Compatible	Compatible
110	Very compatible	Very compatible	Compatible	Compatible	Compatible	Compatible	Compatible	Compatible	Compatible	Compatible	Compatible	Compatible	Compatible
120	Very compatible	Very compatible	Compatible	Compatible	Compatible	Compatible	Compatible	Compatible	Compatible	Compatible	Compatible	Compatible	Compatible

Very compatible Compatible Not compatible



JOB SITE TOOLBOX

<http://tiny.cc/jobsitetoolbox>

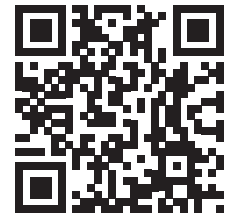

FEATURES & BENEFITS

- Spacious, lockable box for handheld tools
- Easy to lift and transport with MultiOne loader

This robust and versatile toolbox mounts on the attachment coupling plate can be transported with MultiOne loader to the worksite.

The lid is equipped with gas springs and can be locked with a padlock. The box is also equipped with lifting brackets for forklift.

The box keeps handheld tools in good order and is easy to lift into the back of a van or into a safe place for the night.

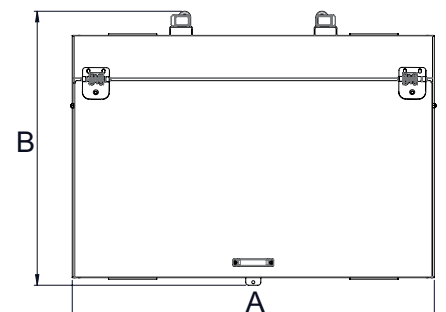
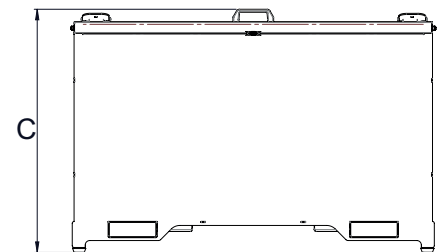

Model	Volume	Width (A)	Length (B)	Height (C)	Weight	Code
Job site Toolbox	618 l (21.8 ft ³)	120 cm (47.2 in)	91 cm (35.8 in)	81 cm (31.9 in)	90 kg (198 lbs)	C890920

Compatibility	1.1	2.3	4.2	5.2	5.3	6.3	7.2	8.4	8.5	11.6	11.9	EZ5	EZ7 EZ8
	Very compatible						Compatible			Not compatible			



HEAVY DUTY SILAGE FORK

<http://tiny.cc/silagefork>



FEATURES & BENEFITS

- Heavy duty frame (except mod. 80)
- Versatile and efficient
- Replaceable teeth
- Compact model, which is well suited for silage distributing in small and confined places

The multi-purposed silage fork, in combination with the frame top hydraulic clamp, makes moving loose or baled silage safe and easy. The extra strength framework allows heavy loads, like round bales, to be safely and effectively moved. The lower fork teeth are easily removed and replaced when worn (except mod. 80).



Model	Width	Teeth length	Nr. of teeth	Max load capacity*	Weight	Code
80**	80 cm (31.5 in)	48 cm (18.9 in)	5	300 kg (660 lbs)	67 kg (148 lbs)	C895061
95	95 cm (37.4 in)	60 cm (23.6 in)	6	600 kg (1322 lbs)	88 kg (194 lbs)	C890355
120	120 cm (47.3 in)	60 cm (23.6 in)	8	800 kg (1763 lbs)	110 kg (242 lbs)	C890356
150	150 cm (59 in)	60 cm (23.6 in)	9	900 kg (1984 lbs)	130 kg (287 lbs)	C890357

(*) verify the lifting capacity of the machine (**) equipped by flat face single lines connections

Compatibility	1.1	2.3	4.2	5.2	5.3	6.3	7.2	8.4	8.5	11.6	11.9	EZ5	EZ7 EZ8
Model													
80	Very compatible	Very compatible	Compatible	Compatible	Compatible	Compatible	Compatible	Compatible	Compatible	Compatible	Compatible	Compatible	Compatible
95	Very compatible	Very compatible	Very compatible	Very compatible	Very compatible	Very compatible	Very compatible	Very compatible	Very compatible	Very compatible	Very compatible	Very compatible	Very compatible
120	Very compatible	Very compatible	Very compatible	Very compatible	Very compatible	Very compatible	Very compatible	Very compatible	Very compatible	Very compatible	Very compatible	Very compatible	Very compatible
150	Very compatible	Very compatible	Very compatible	Very compatible	Very compatible	Very compatible	Very compatible	Very compatible	Very compatible	Very compatible	Very compatible	Very compatible	Very compatible

Very compatible Compatible Not compatible



MANURE FORK

<http://tiny.cc/manurefork>



FEATURES & BENEFITS

- Simple design
- Strong, replaceable teeth
- Designed for excellent visibility from the operator's seat

The manure fork is designed to easily handle loose materials like hay, straw, manure or animal bedding. The simple design promotes easy handling of manure. The strong teeth, made of high tensile forged steel, penetrate also into compacted manure and can carry a heavy load.

Once worn, the fork teeth are quickly and easily replaceable. Two models with different teeth lengths are available.

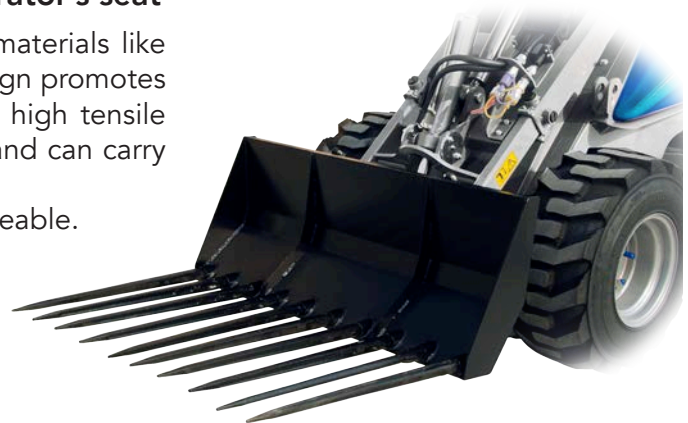

Model	Width	Teeth length	Nr. of teeth	Max load capacity*	Weight	Code
110	110 cm (43.3 in)	110 cm (43.3 in)	10	800 kg (1763 lbs)	85 kg (187.4 lbs)	C890381

(*) verify the lifting capacity of the machine

Compatibility	1.1	2.3	4.2	5.2	5.3	6.3	7.2	8.4	8.5	11.6	11.9	EZ5	EZ7 EZ8

Very compatible
 Compatible
 Not compatible



HAY BALE GRAPPLE

<http://tiny.cc/balegrabber>

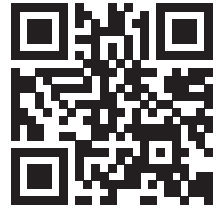

FEATURES & BENEFITS

- Gently but firmly grabs round bales without damaging surface wrap
- Automatically centers the load
- Versatile

This grapple is designed to safely and securely lift and move round hay bales up to 160 cm (5.25 ft) in diameter. The two hydraulically operated clamps provide a great grip over a wide surface area without damaging the bale wrap, and automatically center the load for safe and stable travel and handling. MultiOne machines with their telescopic boom can stack bales even at high heights.



Model	Max bale weight*	Min. Diameter for bale	Max. Diameter for bale	Weight	Code
Hay Bale Grapple	1000 kg (2204 lbs)	97 cm (38.2 in)	160 cm (63 in)	130 kg (287 lbs)	C890410

(* verify the lifting capacity of the machine)

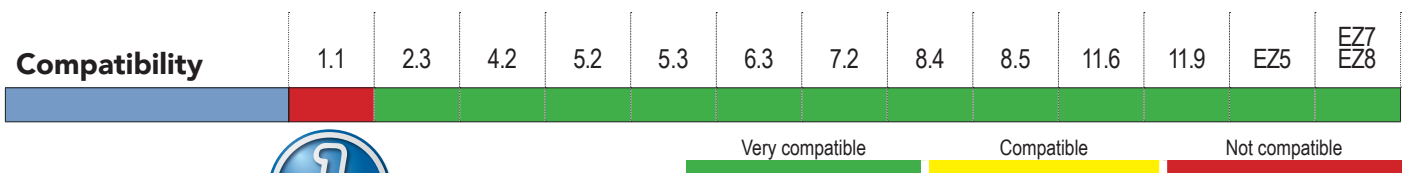

BALE HANDLER

<http://tiny.cc/balehandler>

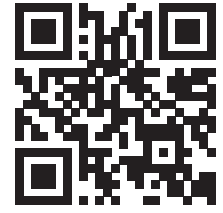

FEATURES & BENEFITS

- Fast and easy way to load and transport bales
- Work perfectly with silage, hay and straw round bales, wrapped bales or unwrapped round bales.
- Adjustable fork wide
- Equipped with rear load support frame

Multione Round Bale Handler is an economical way to handle wrapped bales, without damaging the plastic wrapping. Distance between the forks can be adjusted manually. Bale handler is a good choice if the bales can always be handled sideways and don't need to be grabbed.

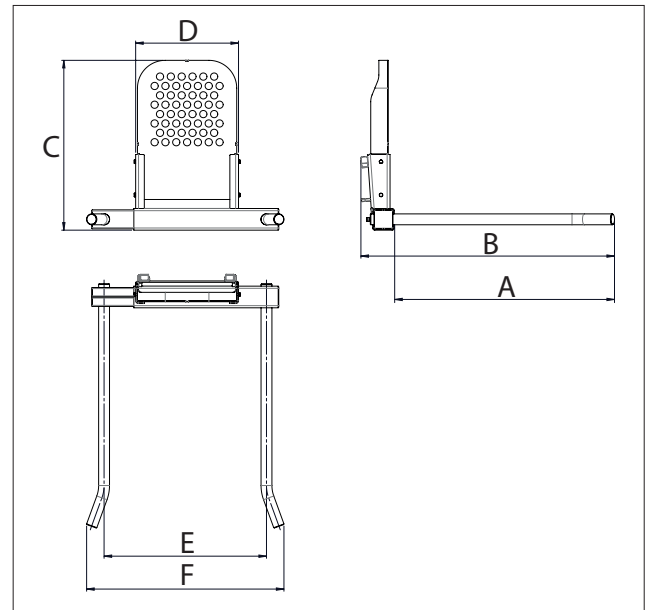

Dimensions						
	A	B	C	D	E (min/max)	F (min/max)
cm	120	140	94	57	90/120	109/139
in	47.2	55.3	37	22.5	35.4/47.2	43/54.8

Model	Forks Length	Max load capacity*	Forks Width min/max	Weight	Code
Bale Handler	120 cm / 47.2 in	1000 kg (2204 lbs)	90 / 120 cm (35 / 47 in)	82 kg (180 lbs)	C890406

(* verify the lifting capacity of the machine)

Compatibility	1.1	2.3	4.2	5.2	5.3	6.3	7.2	8.4	8.5	11.6	11.9	EZ5	EZ7 EZ8
Round Bale Handler													
	Very compatible							Compatible			Not compatible		



SQUARE BALE CLAMP

<http://tiny.cc/squarebales>

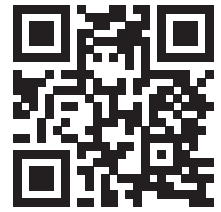

FEATURES & BENEFITS

- Suitable for bales from 75 cm (2.5 ft) to 230 cm (7.6 ft)
- 2 cylinders
- Transport wrapped square bales without damaging the plastic

This clamp was designed to transport and stack round and square bales without damaging the plastic wrapping or net. Made from heavy duty steel, this clamp quickly and easily handles all types of bales, including silage, hay, and straw. The large clamp arms makes pick-up and storage of all bales sizes quick and easy. MultiOne machines with their telescopic boom can stack bales even at high heights.

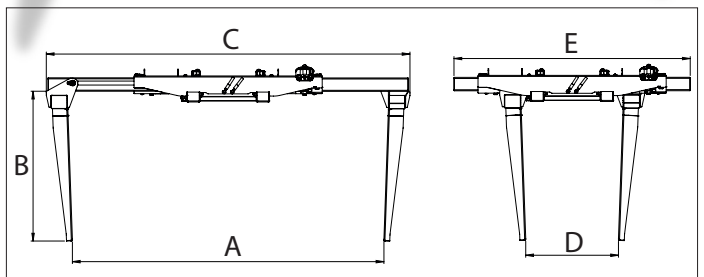

Dimensions					
	A	B	C	D	E
cm	232	112	271	69	176
in	91.2	43.9	106.5	27.2	69.2

Model	Max bale weight*	Min bale length	Max bale length	Weight	Code
Square Bale Clamp	1000 kg (2204 lbs)	75 cm (29.5 in)	230 cm (90.5 in)	270 kg (595 lbs)	C890415

(* verify the lifting capacity of the machine)

Compatibility	1.1	2.3	4.2	5.2	5.3	6.3	7.2	8.4	8.5	11.6	11.9	EZ5	EZ7 EZ8
	Very compatible				Compatible				Not compatible				



BALE FORK

<http://tiny.cc/roundbalefork>



FEATURES & BENEFITS

- Easy and economical way to lift and transport bales
- Two models: 2 or 3 teeth
- Strong, replaceable teeth

Designed to carry any kind of bales, round or square. The load balancing spikes are bolted into the fork body, making them easily replaceable. It is the ideal attachment for gathering hay bales in the field and loading them on trailers. Moreover, the small dimensions make all operations inside stables and barns simple. Strong and simple construction ensures a long lifespan.

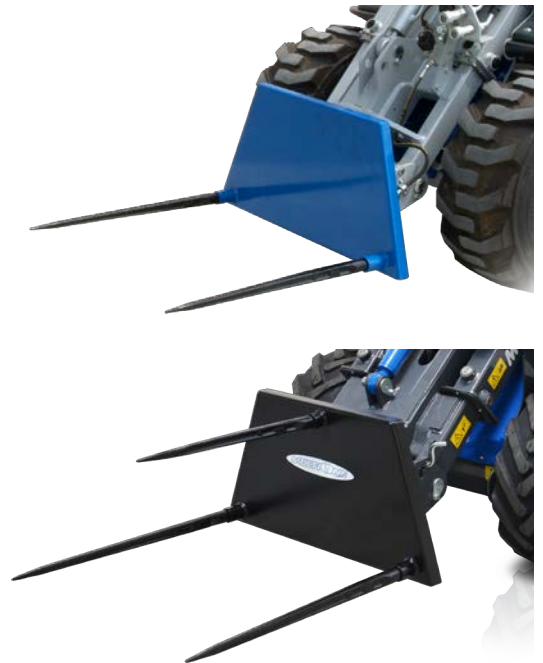

Model	Width	Teeth length	Max load capacity*	Weight	Code
Bale Fork (2 Teeth)	85 cm (33.5 in)	2 x 80 cm (31.5 in)	600 kg (1322 lbs)	40 kg (88.2 lbs)	C890400
Bale Fork (3 Teeth)	85 cm (33.5 in)	2 x 110 cm (43.3 in) + 1 x 80 cm (31.5 in)	600 kg (1322 lbs)	45 kg (99.2 lbs)	C890401

(* verify the lifting capacity of the machine)

Compatibility	1.1	2.3	4.2	5.2	5.3	6.3	7.2	8.4	8.5	11.6	11.9	EZ5	EZ7 EZ8
Model													
Bale Fork (2 Teeth)													
Bale Fork (3 Teeth)													

Very compatible
 Compatible
 Not compatible



HIVE HANDLER

<http://tiny.cc/hiveslifter>

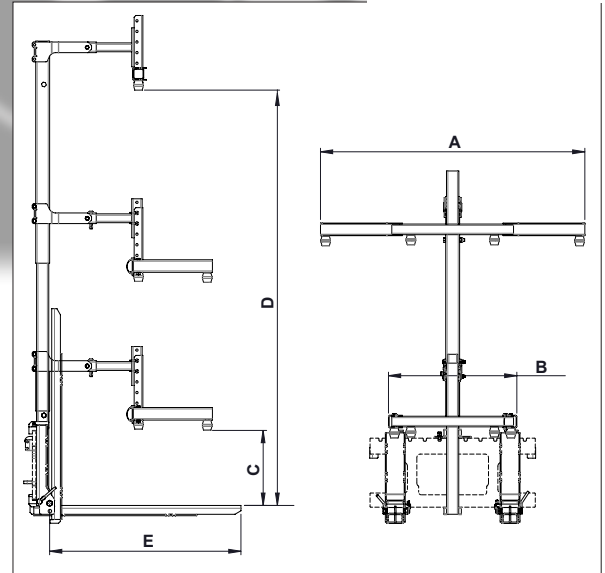

Dimensions (cm / in)				
A	B	C	D	E
152 / 60	74 / 29	43 / 17	235 / 92	115 / 45

FEATURES & BENEFITS

- Fast and easy way to load and transport beehive boxes but also cardboard boxes and similar objects
- Hydraulic load lock
- Foldable forks with adjustable width

MultiOne hive handler is intended basically for loading and transporting of beehive boxes, but it can handle other objects like cardboard boxes as well. The mover can carry many beehives at a time. It consists of a frame, a pallet fork that is mounted on the lower end of the frame, and a hydraulic grapple at the upper end of the frame which presses the boxes against the pallet fork.

The beehive mover can be mounted on MultiOne loaders, and if the beehives need to be transported longer distances by truck it is easy to take the MultiOne on the truck as well and unload and move the beehives at the destination.

Thanks to the compact dimensions and the maneuverability of the MultiOne machines, it will be possible to move the hives even in the most inaccessible and steep places where other machines could not reach. It will also be possible to pass along the narrow rows of orchards to collect fruit crates.

Both the lower forks are adjustable in width and liftable to facilitate transport.

Note: C890335 required. Not compatible with back stop.

Model	Forks Length	Load Height (min/max)	Max load capacity*	Weight	Code
Hive Handler	115 cm (45 in)	43/235 cm (17/92 in)	800 kg (1764 lbs)	155 kg (342 lbs)	C890340

(* verify the lifting capacity of the machine)

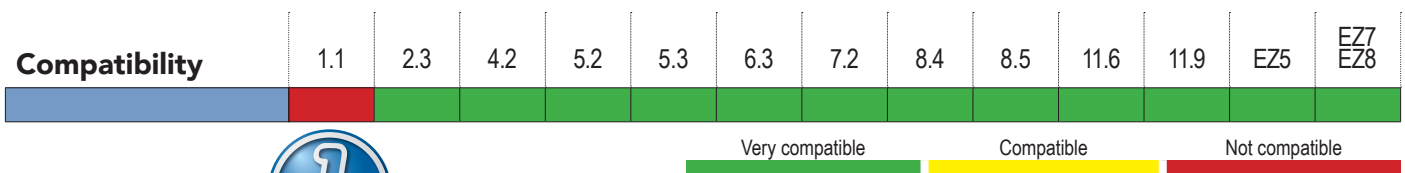

HORSE ARENA HARROW

<http://tiny.cc/horsearenaharrow>

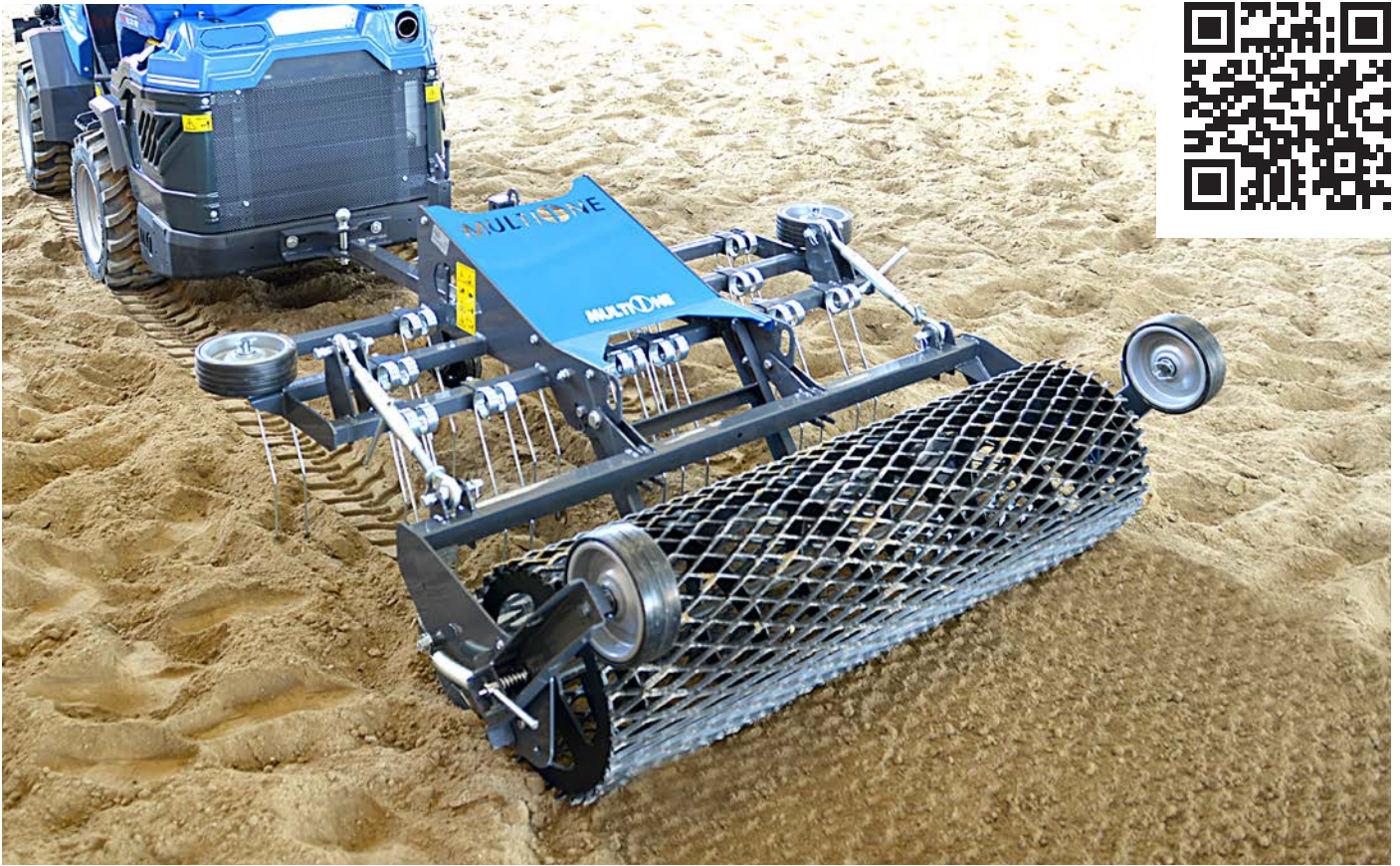

FEATURES & BENEFITS

- Multi-function surface processing
- A professional harrow that makes it easy to keep the horse arena in top condition
- Can be adjusted for several kinds of riding surfaces
- Once the adjustments have been done the harrow is very easy to use

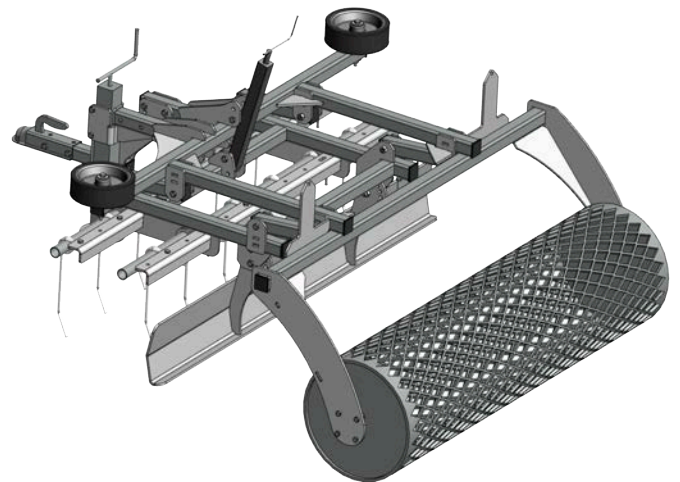

The horse arena harrow is designed to smooth and level sandy or mixed media horse riding surfaces. The harrow features multiple processes, beginning with the two sets of spring tines to break up the surface, a leveler to smooth and level the surface, and the compacting and spreader auger roller assembly that finishes the surface. The harrow also has side wheels that enable working along walls with no damage. Easily made adjustments enable weight and balance adjustments between the spring tines and roller/spreader assembly. Height adjustments to enhance processing difficult soils are made quickly and easily.

Note: the machine must be equipped with the trailer coupling.

Model	Width	Working Depth	Weight	Code
160	160 cm (63 in)	0 - 9 cm (0 - 3.5 in)	290 kg (640 lbs)	C891238
Weights 80 kg (2x40 kg)			80 kg (176 lbs)	C883069
Weights 160 kg (4x40 kg)	/	/	160 kg (352 lbs)	C883077

Compatibility	1.1	2.3	4.2	5.2	5.3	6.3	7.2	8.4	8.5	11.6	11.9	EZ5	EZ7 EZ8
		Very compatible						Compatible			Not compatible		



HORSE STABLE PACKER

<http://tiny.cc/horsetablepacker>

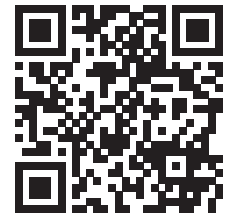

FEATURES & BENEFITS

- Adjustable working width
- Offset left and right

The Horse Stable Packer is a large set of grip tongs for mucking out stalls quickly in a single operation. The adjustable width of the clamp and the wide side shift allow to operate in tight spaces. It is equipped with plastic edges that once worn out can be reversed or replaced.



Model	Working Width	Max Load*	Offset (right / left)	Weight	Code
Horse stable packer	290 - 300 cm (114 - 118 in)	500 kg (1100 lbs)	100 cm (39 in)	236 kg (520 lbs)	C890359

(* verify the lifting capacity of the machine)

Compatibility	1.1	2.3	4.2	5.2	5.3	6.3	7.2	8.4	8.5	11.6	11.9	EZ5	EZ7 EZ8
	Very compatible				Compatible				Not compatible				



FEED DISPENSER

<http://tiny.cc/feeaddispenser>



FEATURES & BENEFITS

- Easy distribution of flour, crushed grain etc.
- Self-loading: loading from ground level like with a normal bucket

MultiOne's animal feed dispenser bucket makes feeding the animals quick and easy. The front edge of the feed dispenser bucket can be used to easily fill up the bucket feeder. Feed is dispensed from the right side discharge chute, using the hydraulically powered auger located at the bottom of the feeder. The feed dispenser is designed to handle any sized grain and mix, making animal feeding a quick and simple process.



Model	Capacity*	Width	Discharge Side	Weight	Code
350	350 l (12.4 ft ³)	130 cm (51.2 in)	Right	140 kg (309 lbs)	C890420
520	520 l (18.4 ft ³)	180 cm (70.9 in)	Right	210 kg (463 lbs)	C890421

(* verify the lifting capacity of the machine)

Compatibility	1.1	2.3	4.2	5.2	5.3	6.3	7.2	8.4	8.5	11.6	11.9	EZ5	EZ7 EZ8
Model													
350													
520													

Very compatible
 Compatible
 Not compatible



SCREW FEED PUSHER

<http://tiny.cc/feedpusher>



FEATURES & BENEFITS

- Fast and easy way of moving feed to the animals
- Discharge on the right side
- High efficiency, also on larger farms
- Rear rubber scraper blade

Efficient way of moving uneaten feed back in front of the cattle. When moving, the screw mixes the feed and the fresh feed remains on top.

With the screw feed pusher drive speed can be higher. The rubber scraper blade at the rear of the attachment cleans the floor very efficiently. Once worn out, the rubber blade can be disassembled and reassembled backwards or replaced.

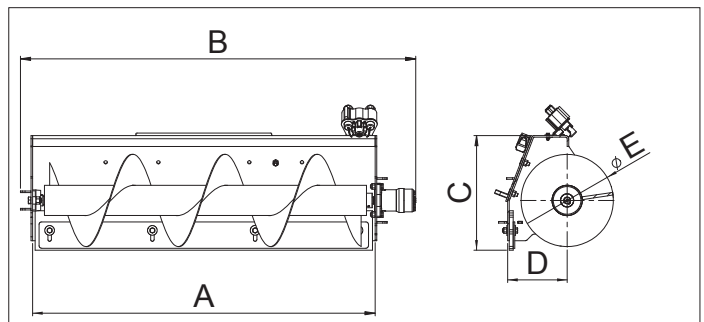

		Dimensions				
		A	B	C	D	E
cm		130	150	44	23	35
in		51.2	59	17.1	8.9	13.8

Model	Working Width	Height	Weight	Code
Screw Feed Pusher	130 cm (51.2 in)	44 cm (17.3 in)	115 kg (254 lbs)	C890250

Compatibility	1.1	2.3	4.2	5.2	5.3	6.3	7.2	8.4	8.5	11.6	11.9	EZ5	EZ7 EZ8

Very compatible
 Compatible
 Not compatible



RUBBER SCRAPER

<http://tiny.cc/rubberscraper>

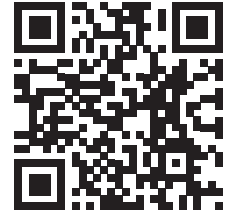

FEATURES & BENEFITS

- Heavy duty rubber blade
- Simple and efficient
- Each ends of the scraper blade can be adjusted forwards

The MultiOne rubber scraper is ideal for cleaning smooth surfaces in farm buildings and yards, improving hygiene and footing. It is also a easy and economical way to push uneaten silage back to the cattle on the feeding table.

The side ends can be tilted 30° forward to facilitate the movement of the material. Once worn out, the rubber blade can be disassembled and reassembled backwards or replaced.



Model	Width	Rubber Height	Weight	Code
150	150 cm (59 in)	35 cm (13.8 in)	73 kg (161 lbs)	C890361
200	200 cm (78.7 in)	35 cm (13.8 in)	86 kg (190 lbs)	C890358

Compatibility	1.1	2.3	4.2	5.2	5.3	6.3	7.2	8.4	8.5	11.6	11.9	EZ5	EZ7 EZ8
Model													
150	Very compatible	Compatible	Compatible	Compatible	Compatible	Compatible	Compatible	Compatible	Compatible	Compatible	Compatible	Compatible	Compatible
200	Not compatible	Compatible	Compatible	Compatible	Compatible	Compatible	Compatible	Compatible	Compatible	Compatible	Compatible	Compatible	Compatible

Very compatible Compatible Not compatible



PUSH BROOM

<http://tiny.cc/pushbroom>



FEATURES & BENEFITS

- Simple design creates minimal dust
- Few moving parts means low maintenance
- Works perfectly for horse stables, farms, other brushing applications

The Push broom from MultiOne provides an economical solution to clear dirt on stables and farms, but it can be used to remove fallen leaves and other outdoor materials over a smaller area, like sidewalks or parking. This push broom uses a simple design that creates minimal dust while preventing flying stones or other debris. The brush is constructed from heavy-gauge polypropylene, providing long-lasting performance. There are two adjustable wheels that keep the height of the brush constant from the ground. The push broom is equipped with supports which can be extended when the broom is not in use, so that the push broom rests on the supports and the brush doesn't get damaged during storage. There are two slits where insert the pallet forks.

Note: the floating boom valve on the machine is suggested.



Model	Max Width	Brush Width	Length	Brush Height	Weight	Code
Push Broom	184 cm (72.5 in)	160 cm (63 in)	72 cm (28.3 in)	25 cm (9.8 in)	205 kg (452 lbs)	C890255

Compatibility	1.1	2.3	4.2	5.2	5.3	6.3	7.2	8.4	8.5	11.6	11.9	EZ5	EZ7 EZ8

HYDRAULIC BREAKER

<http://tiny.cc/hydraulicbreaker>



FEATURES & BENEFITS

- Top quality sound isolated MultiOne breakers are quiet and powerful
- High power-to-weight ratio
- Compact dimensions

The narrow breaker profile enables the breaker to reach into places that other breakers can't. With a minimum of seals and moving parts, the MultiOne hydraulic breaker provides unsurpassed durability and simplified maintenance. It is equipped with a vibration damping system that also attenuates noise emission. MultiOne loader with breaker is a very efficient tool in demolition and refurbishing operations: do the demolition with Multione and breaker, take the debris away with Multione and bucket – very fast and effective. Another benefit of this combination is its compact dimensions: you can go almost anywhere with this unit.

Note: the floating boom valve on the machine is suggested.

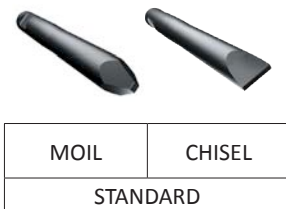

Model	Impact energy	Impact rate	Ø Tool	Weight	Code
SB70	280 J	1750 bpm	40 mm (1,5 in)	70 kg (154 lbs)	C890166
SB100	400 J	2300 bpm	45 mm (1,8 in)	100 kg (220 lbs)	C890167
SB200	750 J	1900 bpm	55 mm (2,1 in)	190 kg (418 lbs)	C890168

Compatibility	1.1	2.3	4.2	5.2	5.3	6.3	7.2	8.4	8.5	11.6	11.9	EZ5	EZ7 EZ8
Model													
SB70													
SB100													
SB200													

Very compatible
 Compatible
 Not compatible



DOZER BLADE

<http://tiny.cc/dozerblade>



FEATURES & BENEFITS

- Rugged design delivers maximum uptime
- Dozer blade can be angled 30 degrees left and right

The MultiOne dozer blade can be angled from the driver's seat, either on the right or on the left, thanks to a sturdy hydraulic cylinder. It is equipped with two adjustable back shoes to set the working depth. It can be used for a wide variety of jobs, from scraping hard soils, to grading and stacking loose soils, quick and easy. An ideal tool for projects from rough construction through fine landscaping. Thanks to the excellent traction and the high pushing force of the MultiOne machines, it can also be used for heavy-duty earthmoving jobs.

It must not be used for snow removal along roads and parking lots (in this cases must be used the snow plow or snow blade).



Model	Width	Slewing angle	Height	Weight	Code
140	140 cm (55.1 in)	±30°	53 cm (20.8 in)	90 kg (198 lbs)	C890470
180	180 cm (71 in)	±30°	53 cm (20.8 in)	105 kg (232 lbs)	C890477

Compatibility	1.1	2.3	4.2	5.2	5.3	6.3	7.2	8.4	8.5	11.6	11.9	EZ5	EZ7 EZ8
Model													
140													
180													

Very compatible
 Compatible
 Not compatible



TRENCHER

<http://tiny.cc/trencher>



FEATURES & BENEFITS

- Minimal damage to the ground on trenching area
- Digs from 14 to 20 cm (5.5 to 7.9 in) wide trench and moves all ground to the right side of the trench
- Very fast and clean way to dig trenches for cables, drains, piping etc.

With MultiOne trencher you can easily dig narrow trenches without damaging the ground on the digging area. The trencher does a clean trench which can easily be filled with a bucket or a dozer blade. Planetary drive with hydraulic motor guarantees powerful and trouble free operation. Max digging depths are 60, 90 and 120 cm (23.6, 35.4 and 47.2 in) respectively, depending on model. Digging width is either 14, 16, 18 or 20 cm (5.5, 6.3, 7.1 or 7.9 in), every chain tools kit can be set for different widths. Hard ground version chains have tungsten reinforcements to ensure long lasting performance in hard and rocky soil, otherwise the standard version is the best choice for vegetative ground.

- Trencher is ideal for smaller cable or pipe laying.
- Digging speed with a trencher is 2-3 times quicker compared to a backhoe.
- Combination of an articulated MultiOne and trencher leaves almost no marks of digging operations after the work is done. This makes it a perfect solution for gardens and other lawn areas.

It features an adjustable depth control foot which ensures the operator digs at a set depth at all times and efficient spoil removal for effective compaction back into the trench.

Model	Max Digging Depth	Max Digging Width	Weight	Code
Trencher 60 w/o chain tools ¹	60 cm (23.6 in)	14 to 20 cm (5.5 to 7.9 in)	205,5 kg (453 lbs)	C890206
Trencher 90 w/o chain tools ¹	90 cm (35.4 in)	14 to 20 cm (5.5 to 7.9 in)	235 kg (518 lbs)	C890207
Trencher 120 w/o chain tools ¹	120 cm (47.2 in)	14 to 20 cm (5.5 to 7.9 in)	248 kg (547 lbs)	C890208
Tools	Trencher 60	Trencher 90	Trencher 120	
Tools kit for soft ground ²	C891002	C891003	C891004	
Tools kit for hard ground ²	C891005	C891006	C891007	

(¹) Tools kit required. (²) Trencher required.

Compatibility	1.1	2.3	4.2	5.2	5.3	6.3	7.2	8.4	8.5	11.6	11.9	EZ5	EZ7 EZ8
Model													
60 - soft ground	Red	Green	Green	Green	Green	Green	Green	Green	Green	Green	Green	Red	Red
90 - soft ground	Red	Red	Red	Yellow	Yellow	Yellow	Yellow	Yellow	Yellow	Yellow	Yellow	Red	Red
120 - soft ground	Red	Red	Red	Yellow	Yellow	Yellow	Yellow	Yellow	Yellow	Yellow	Yellow	Red	Red
60 - hard ground	Red	Yellow	Yellow	Green	Green	Green	Green	Green	Green	Green	Green	Red	Red
90 - hard ground	Red	Yellow	Yellow	Yellow	Yellow	Yellow	Yellow	Yellow	Yellow	Yellow	Yellow	Red	Red
120 - hard ground	Red	Yellow	Yellow	Yellow	Yellow	Yellow	Yellow	Yellow	Yellow	Yellow	Yellow	Red	Red

Very compatible (Green) Compatible (Yellow) Not compatible (Red)



MINI DIGGER

<http://tiny.cc/minidigger>

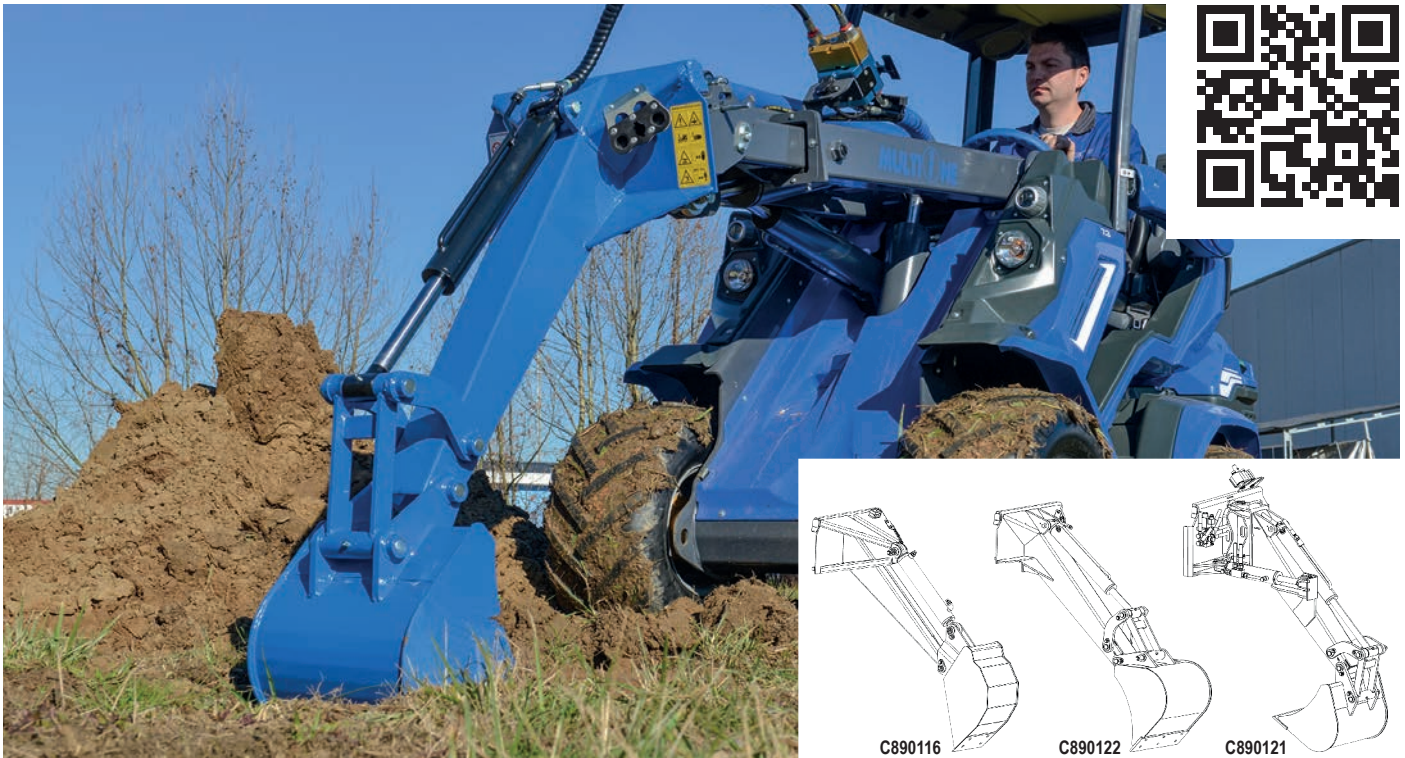

FEATURES & BENEFITS

- Efficient and economical solution for smaller digging jobs
- 90° rotation model available
- Very fast to mount on Multione
- Simple and light to transport from job site to another
- High unloading height
- Material can easily be transported further away

MultiOne mini digger is an efficient solution for small digging operations where maximum digging depth of 1200 mm or 1500 mm is enough and digging is not an everyday work. It mounts directly on the quick attach plate of the loader and is operated with the auxiliary hydraulics control lever, or with the buttons of the joystick.

Dumping to the side is happens by turning the steering wheel of the MultiOne.

It's also available a model with 90° (45° to left and 45° to right) hydraulic rotation for easy work. Three models of buckets are available (only for C890121 and C890122 models) and digging teeth can be installed for the hardest terrains. 2 teeth for Bucket 25 cm, 3 teeth for Bucket 40 cm and 5 teeth for Bucket 70 cm.

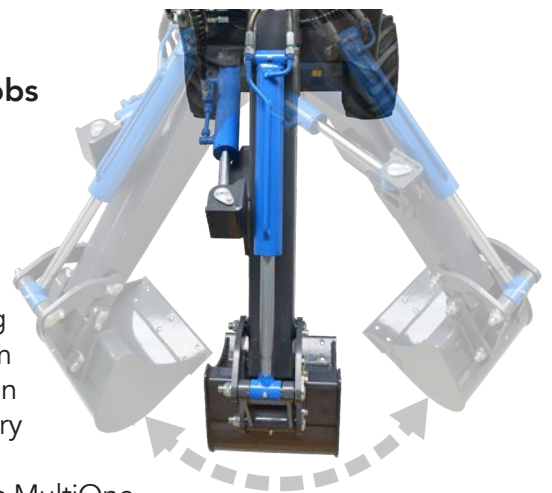

Model	Length	Volume	Weight	Code
Mini-digger 130 with bucket 25 cm (9.8 in)	130 cm (51.2 in)	15,5 l (0.55 ft ³)	70 kg (154 lbs)	C890116
Mini-digger 150 w/o bucket (bucket required)	150 cm (59 in)	/	52 kg (115 lbs)	C890122
Mini-digger 165 with rotation w/o bucket (bucket required)	165 cm (65 in)	/	102 kg (225 lbs)	C890121
Options				
Bucket 25 cm (9.8 in) only for C890121 and C890122		15,5 l (0.55 ft ³)	25 kg (55 lbs)	C890123
Bucket 40 cm (15.7 in) only for C890121 and C890122		26 l (0.92 ft ³)	28 kg (62 lbs)	C890129
Bucket 70 cm (27.5 in) only for C890121 and C890122		47 l (1.66 ft ³)	47 kg (104 lbs)	C890124
Bolt-on tooth kit (each)		/	1,7 kg (3.7 lbs)	C890007

Compatibility	1.1	2.3	4.2	5.2	5.3	6.3	7.2	8.4	8.5	11.6	11.9	EZ5	EZ7 EZ8
Model													
130													
150 / 165 with rotation													

Very compatible
 Compatible
 Not compatible



SCREENING BUCKET

<http://tiny.cc/screeningbucket>



FEATURES & BENEFITS

- Heavy duty construction
- Easy and fast processing
- Separates stone/soil/vegetation
- Screens without crushing or shredding
- Suitable for different types of soil
- Separate project materials on-site, saving time and money

The MultiOne screening bucket separates different sized materials thanks to its unique construction. The purpose of the screening bucket is to separate larger and smaller particles from the soil and not crush the larger material into smaller particles.

The bucket design allows to load and unload the material quickly and easily.

Topsoil making for landscaping, nurseries and wholesale is the principal use while some construction contractors utilize the bucket for screening.

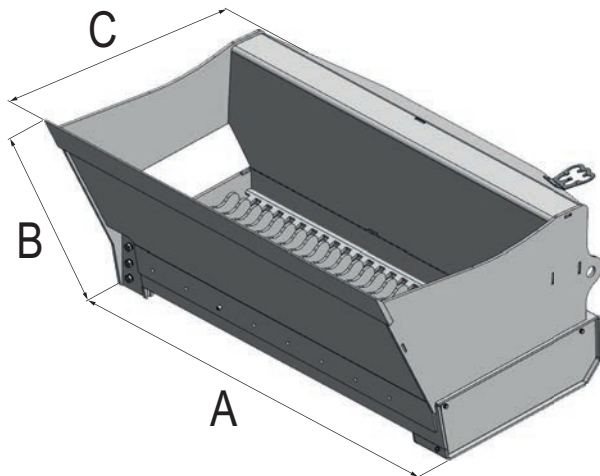

Dimensions (cm/in)		
A	B	C
118 / 46.3	62 / 24.4	102 / 40.3

Model	Max Load*	Volume	Width (A)	Screened materials (LxHxW)	Weight	Code
Screening bucket	280 kg (617 lbs)	250 l (8.8 ft ³)	120 cm (47.2 in)	20 - 20 - 35 mm (0.8 - 0.8 - 1.4 in)	320 kg (705 lbs)	C890030

(* verify the lifting capacity of the machine)

Compatibility	1.1	2.3	4.2	5.2	5.3	6.3	7.2	8.4	8.5	11.6	11.9	EZ5	EZ7 EZ8



RADIO CONTROLLED BACKHOE

<http://tiny.cc/rcbackhoe>



FEATURES & BENEFITS

- Full Visibility
- Proportional controls
- Fast and easy to use

The MultiOne Backhoe it's a best seller attachment: sturdy, reliable with a huge pushing force and almost 180° rotation. MultiOne believes in the continuous improvement: from now on it's available the radio controlled version of MultiOne Backhoe! The proportional controls assure smooth and accurate movements. Thanks to the radio control the operator's seat and hydraulic control are no longer necessary: you can control the backhoe directly from the machine seat or occupy the best position to see the digging area.

It's the best choice to operate on tight spaces and wherever the digging precision it's required. Three models of buckets are available and digging teeth can be installed: 2 teeth for Bucket 25 cm, 3 teeth for Bucket 40 cm and 5 teeth for Bucket 70 cm.

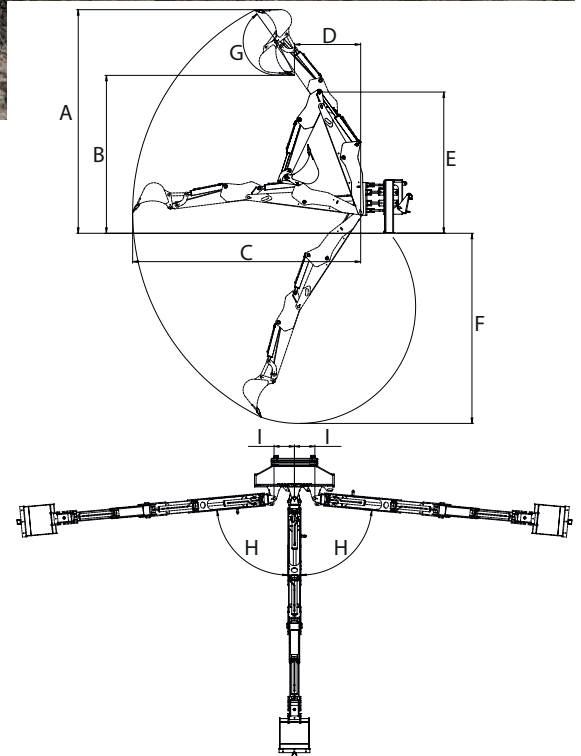

Mod.	A	B	C	D	E	F	G	H	I	
215	270 cm (106.4 in)	177 cm (69.5 in)	271 cm (106.6 in)	73 cm (28.7 in)	175 cm (68.8 in)	221 cm (87 in)	172°	85°	27 cm (10.5 in)	
260	314 cm (123.6 in)	222 cm (87.4 in)	320 cm (126 in)	93 cm (36.6 in)	198 cm (78.1 in)	267 cm (105 in)	172°	85°	27 cm (10.5 in)	
Model				Digging Depth		Volume		Weight		Code
Backhoe 215 w/o bucket (bucket required)				215 cm (84.6 in)		/		482 kg (1063 lbs)		C890125
Backhoe 260 w/o bucket (bucket required)				260 cm (102.4 in)		/		552 kg (1217 lbs)		C890126
Options										
Bucket 25 cm (9.8 in)			/	25 cm (9.8 in)		15,5 l (0.55 ft ³)		25 kg (55 lbs)		C890123
Bucket 40 cm (15.7 in)			/	40 cm (15.7 in)		26 l (0.92 ft ³)		28 kg (62 lbs)		C890129
Bucket 70 cm (27.5 in)			/	70 cm (27.5 in)		47 l (1.66 ft ³)		47 kg (104 lbs)		C890124
Bolt-on tooth kit (each)			/	/		/		1,7 kg (3.7 lbs)		C890007

Compatibility	1.1	2.3	4.2	5.2	5.3	6.3	7.2	8.4	8.5	11.6	11.9	EZ5	EZ7 EZ8
Model													
215													
260													

Very compatible
 Compatible
 Not compatible



AUGER

<http://tiny.cc/auger>

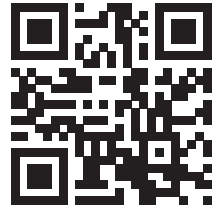

FEATURES & BENEFITS

- Wide range of auger drive units with different torques enables efficient use of 10 cm (4 in) to 100 cm (40 in) augers
- Augers with tungsten teeth available

The powerful hydraulic auger drive unit, combined with various auger diameters, provide excellent flexibility in all soil types.

The auger is the ideal accessory to perform holes for fences, poles for vineyards, for trees planting, for the installation of pillars or streetlights in all types of terrain. The auger drive is available in three versions:

- T1 for normal soil conditions
- T2 for hard, rocky ground, used with augers up to 50 cm (20 in)
- T3 for hard, rocky ground, used with augers up to 100 cm (40 in)

A large variety of augers are also available with replaceable tungsten teeth for the most difficult terrains, and it is also possible to install extensions, each 1 m long, to reach greater digging depths. The augers are equipped with a special joint that allows to make a perfect vertical hole no matter how the machine is positioned. The auger combined with the high hydraulic flow of MultiOne machines allows to drill holes quickly in any terrain.



Model	Torque	Drills	Weight	Code
T1 – standard drive unit	100 kgm	10 - 50 cm (4 - 19.7 in)	90 kg (198 lbs)	C890830
T2 – heavy duty drive unit	180 kgm	10 - 50 cm (4 - 19.7 in)	110 kg (242 lbs)	C890831
T3 – heavy duty drive unit	400 kgm	30 - 100 cm (11.8 - 39.4 in)	150 kg (331 lbs)	C890832

Compatibility	1.1	2.3	4.2	5.2	5.3	6.3	7.2	8.4	8.5	11.6	11.9	EZ5	EZ7 EZ8
Model													
T1	Very compatible	Compatible	Compatible	Compatible	Compatible	Compatible	Compatible	Compatible	Compatible	Compatible	Compatible	Not compatible	Not compatible
T2	Very compatible	Compatible	Compatible	Compatible	Compatible	Compatible	Compatible	Compatible	Compatible	Compatible	Compatible	Not compatible	Not compatible
T3	Very compatible	Compatible	Compatible	Compatible	Compatible	Compatible	Compatible	Compatible	Compatible	Compatible	Compatible	Not compatible	Not compatible

Very compatible Compatible Not compatible



OPTIONS FOR AUGER

Heavy Duty Auger Drill	Diameter	Length	Code
10	10 cm (4 in)	100 cm (39.4 in)	C890840
15	15 cm (6 in)	100 cm (39.4 in)	C890841
20	20 cm (7.9 in)	100 cm (39.4 in)	C890842
25	25 cm (9.8 in)	100 cm (39.4 in)	C890843
30	30 cm (11.8 in)	100 cm (39.4 in)	C890844
35	35 cm (13.8 in)	100 cm (39.4 in)	C890845
40	40 cm (15.7 in)	100 cm (39.4 in)	C890846
50	50 cm (19.7 in)	100 cm (39.4 in)	C890847
60 - T3 auger only	60 cm (23.6 in)	100 cm (39.4 in)	C890849
70 - T3 auger only	70 cm (27.6 in)	100 cm (39.4 in)	C890851
80 - T3 auger only	80 cm (31.5 in)	100 cm (39.4 in)	C890853
90 - T3 auger only	90 cm (35.4 in)	100 cm (39.4 in)	C890855
100 - T3 auger only	100 cm (39.4 in)	100 cm (39.4 in)	C890857
Auger Drill w/tungsten teeth Rock Drill	Diameter	Length	Code
15	15 cm (6 in)	100 cm (39.4 in)	C890880
20	20 cm (7.9 in)	100 cm (39.4 in)	C890881
25	25 cm (9.8 in)	100 cm (39.4 in)	C890882
30	30 cm (11.8 in)	100 cm (39.4 in)	C890883
35	35 cm (13.8 in)	100 cm (39.4 in)	C890884
40	40 cm (15.7 in)	100 cm (39.4 in)	C890885
50	50 cm (19.7 in)	100 cm (39.4 in)	C890886
60 - T3 auger only	60 cm (23.6 in)	100 cm (39.4 in)	C890888
70 - T3 auger only	70 cm (27.6 in)	100 cm (39.4 in)	C890890
80 - T3 auger only	80 cm (31.5 in)	100 cm (39.4 in)	C890892
90 - T3 auger only	90 cm (35.4 in)	100 cm (39.4 in)	C890894
100 - T3 auger only	100 cm (39.4 in)	100 cm (39.4 in)	C890896
Auger Drill Extension	Diameter	Length	Code
10	10 cm (4 in)	100 cm (39.4 in)	C890860
15	15 cm (6 in)	100 cm (39.4 in)	C890861
20	20 cm (7.9 in)	100 cm (39.4 in)	C890862
25	25 cm (9.8 in)	100 cm (39.4 in)	C890863
30	30 cm (11.8 in)	100 cm (39.4 in)	C890864
35	35 cm (13.8 in)	100 cm (39.4 in)	C890865
40	40 cm (15.7 in)	100 cm (39.4 in)	C890866
50	50 cm (19.7 in)	100 cm (39.4 in)	C890867
60 - T3 auger only	60 cm (23.6 in)	100 cm (39.4 in)	C890869
70 - T3 auger only	70 cm (27.6 in)	100 cm (39.4 in)	C890871
80 - T3 auger only	80 cm (31.5 in)	100 cm (39.4 in)	C890873
90 - T3 auger only	90 cm (35.4 in)	100 cm (39.4 in)	C890875
100 - T3 auger only	100 cm (39.4 in)	100 cm (39.4 in)	C890877

GRADER

<http://tiny.cc/grader>

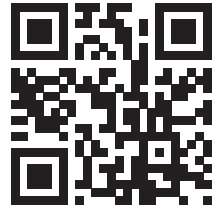

FEATURES & BENEFITS

- **Optional laser control package for precise grade control**

The grader attachment converts the MultiOne machine into a high performance grading system, well suited for confined areas not accessible to larger machines. It is possible to level roads, squares, playgrounds and carefully lay gravel and sand.

The hydraulically controlled moldboard is controlled using the cab mounted auxiliary controls. To increase the grader efficiency and precision, the MultiOne's grader can be equipped with an optional laser control system. The grader is equipped with two front wheels mounted on a floating frame that assures the stability even on uneven ground.

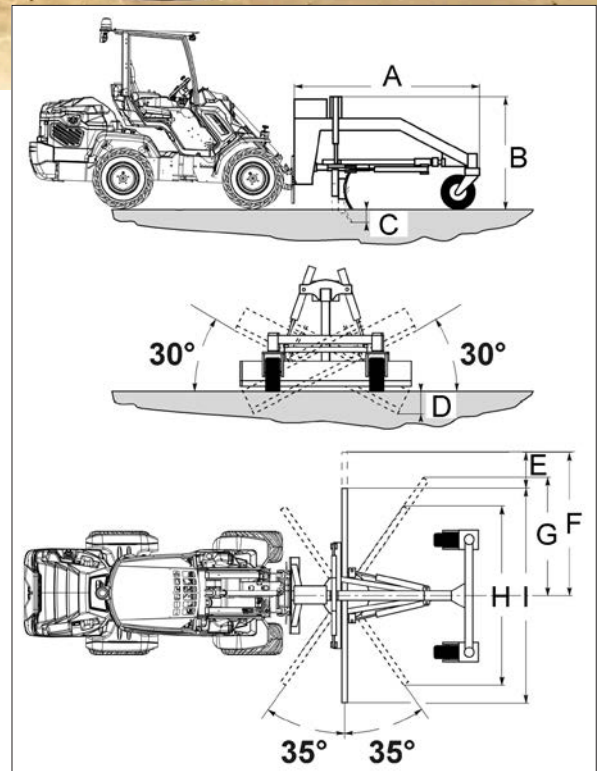

	A	B	C	D	E	F	G	H	I
cm	222	132	16,5	35,5	40	147	109	174	213
in	87.4	51.9	6.5	14	15.7	57.7	42.9	68.3	83.8

Model	Blade width	Weight	Code
Grader with hydraulic controls	210 cm (82.7 in)	550 kg (1212 lbs)	C890105
Laser (receiver only) twin angle	/	/	C890106

Compatibility	1.1	2.3	4.2	5.2	5.3	6.3	7.2	8.4	8.5	11.6	11.9	EZ5	EZ7 EZ8
	Very compatible							Compatible			Not compatible		



CEMENT MIXER

<http://tiny.cc/cementmixer>

FEATURES & BENEFITS

- Faster than a stand alone mixer
- Designed to work in hard-to-reach areas
- Easy way to make concrete in places where electricity is not available
- Bidirectional rotation

The hydraulically powered cement mixer is an inexpensive attachment that lets you mix, transport, and pours concrete faster than a stand-alone mixer. This unit's compact size makes it the ideal tool when working on sidewalks, driveways, footings, small building floors, and other hard-to-reach or limited access areas where electricity is not available.

The concrete can be mixed in the deposit material area and then quickly transported to the working area. Thanks to the lifting boom of MultiOne machines, even the concrete pouring is much easier. The solid structure and direct drive transmission ensure long life and low maintenance.



Model	Volume*	Weight	Code
Cement Mixer	350 l (12.4 ft ³)	95 kg (210 lbs)	C890131

(*) verify the lifting capacity of the machine

Compatibility	1.1	2.3	4.2	5.2	5.3	6.3	7.2	8.4	8.5	11.6	11.9	EZ5	EZ7 EZ8
	Very compatible						Compatible			Not compatible			

CONCRETE MIXING BUCKET

<http://tiny.cc/concretemixingbucket>

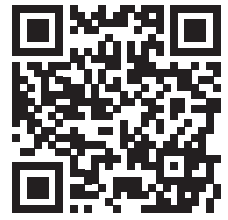

FEATURES & BENEFITS

- Hydraulically powered mixing and unloading system
- Easy and efficient way to make concrete in places where electricity is not available
- Self loading, sand can be taken to the bucket directly from the pile
- Concrete can be poured over 2 m height
- Removable safety grill promotes easy cleaning and maintenance

The concrete mixing bucket allows the operator to load, mix, transport, and discharge concrete much faster than the traditional stand-alone mixer and wheel barrow. This unit's compact size, when combined with the MultiOne machine, makes it ideal for pouring sidewalks, driveways, footings, small buildings floors, and many other limited access locations. The bucket is emptied from the bottom hatch. Hatch opening is powered by a hydraulic cylinder controlled from driver's seat. The bucket is also equipped with a flexible emptying tube which mounts on the bottom hatch. This enables pouring of the concrete further away from the bucket. Designed for high volume production, this unit minimizes downtime.



Combined with the MultiOne, it becomes an high-performance, reliable, and cost efficient system.

Model	Volume*	Outlet Ø	Hose Length	Weight	Code
200	200 l (7 ft ³)	13,5 cm (5.3 in)	160 cm (63 in)	220 kg (485 lbs)	C890140
250	250 l (8.8 ft ³)	18 cm (7.1 in)	150 cm (59 in)	320 kg (706 lbs)	C890141

(*) verify the lifting capacity of the machine

Compatibility	1.1	2.3	4.2	5.2	5.3	6.3	7.2	8.4	8.5	11.6	11.9	EZ5	EZ7 EZ8
Model													
200													
250													

Very compatible
 Compatible
 Not compatible



COLD PLANER

<http://tiny.cc/coldplaner>

FEATURES & BENEFITS

- Great cold planing ability
- Planer drum improves planer efficiency
- Available with drum or cutting disk
- Side shift as standard

Ideal design for milling damaged asphalt and concrete surfaces in preparation for resurfacing.

The cold planer can be converted from surface planing to slot cutting. Use a cutting disk for cutting expansion crack slots, or slots for embedding wires or tubing.

The standard planer drum, equipped with carbide cutting teeth and the self leveling suspension, efficiently planes the pavement surface.

The small size combined with the great efficiency make it suitable for working in confined spaces hard-to-reach. The drum is equipped with replaceable teeth when worn out.

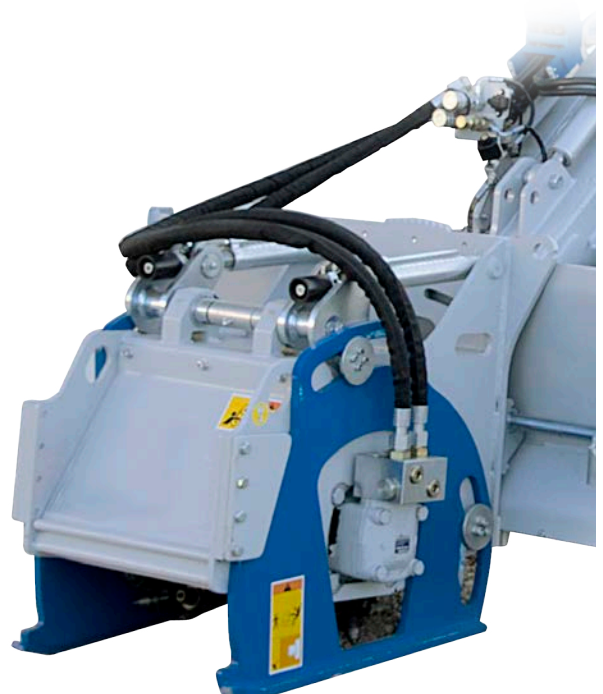

Model	Digging depth	Max planing width	Max side shift	Weight	Code
Cold Planer	11 cm (4 in)	35 cm (13.8 in)	65 cm (25.6 in)	620 kg (1367 lbs)	C890160
Cutting disk	15 cm (6 in)	7,5 cm (3 in)	65 cm (25.6 in)	/	C890162

Compatibility	1.1	2.3	4.2	5.2	5.3	6.3	7.2	8.4	8.5	11.6	11.9	EZ5	EZ7 EZ8
	Very compatible							Compatible			Not compatible		

PIPE LAYER RIPPER

<http://tiny.cc/pipelayerripper>



FEATURES & BENEFITS

- Designed for laying water pipe or armoured cable
- Up to 3 cm (1,2 in) diameter pipe
- Heavy duty and simple to operate
- Adjustable ripping depth

Ideal for laying water pipe or armoured cable or for installing irrigation systems in gardens, the attachment benefits from being quick and easy to use. Suitable for flexible pipe or cabling up to 3 cm (1,2 in) in size. The ripping depth is adjustable from 10 cm (4 in) to 20 cm (8 in), by setting the height of the two wheels. The ripping depth also depending on the power of the machine and soil type. The pipe layer ripper can be equipped with large pipe reel, up to 60 cm (24 in) in diameter and 30 cm (12 in) width.

The tine position and the pipe reel stand are adjustable.

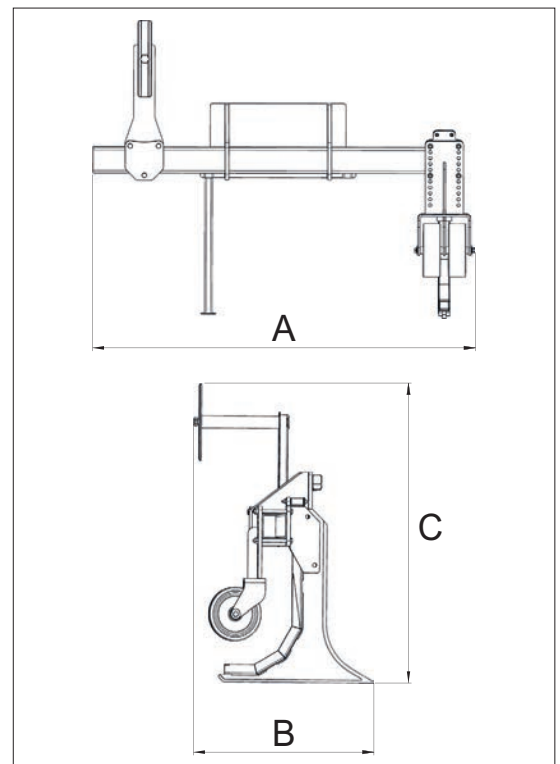

Dimensions (cm/in)		
A	B	C
150 / 59	67 / 26	106 / 42

Model	Max pipe diameter	Ripping Depth	Max pipe reel size (Ø x width)	Weight	Code
Pipe layer ripper	30 mm (1,2 in)	10÷20 cm (4÷8 in)	60x30 cm (24x12 in)	115 kg (254 lbs)	C891330

Compatibility	1.1	2.3	4.2	5.2	5.3	6.3	7.2	8.4	8.5	11.6	11.9	EZ5	EZ7 EZ8

Very compatible
 Compatible
 Not compatible

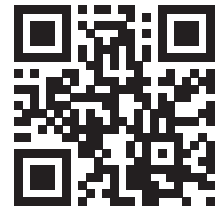

SWEEPER WITH COLLECTOR BOX

<http://tiny.cc/sweeper2>

FEATURES & BENEFITS

- Powerful sweeper for large areas
- Side brush available
- Humidification kit available

Whether traveling forward or backwards, this attachment quickly and quietly sweeps and collects dirt and debris, and easily dumps out the refuse. Perfect system for cleaning parking lots, sidewalks, loading docks, warehouses, and more. The MultiOne sweeper is equipped with a floating attachment bracket and 4 support wheels that guarantee smooth and easy sweeping operations. The sweeping angle is manually adjusted (30° to the left and + 30° to the right). Optional: 1) Collector box with electric opening (12V socket required). 2) Dust reduction water spray system is made up of a 12V electric pump, 4 spray nozzles, and one or two water tanks (ACI or 12V socket required). 3) A single 500 mm (20 in) hydraulically driven side brush can be mounted on the right side of the collector box.

Note: the floating boom valve on the machine is suggested.

Model	Working Width	Diameter	Volume	Weight	Code
Sweeper 110 with waste box	110 cm (43 in)	50 cm (19.6 in)	82 l (2.9 ft ³)	170 kg (375 lbs)	C890990
Sweeper 120	120 cm (47 in)	48 cm (19 in)	/	153 kg (337 lbs)	C890265
Sweeper 150	150 cm (59 in)	48 cm (19 in)	/	173 kg (381 lbs)	C890267
Waste box for Sweeper 120	120 cm (47 in)	/	90 l (3,2 ft ³)	50 kg (110 lbs)	C890266
Waste box for Sweeper 150	150 cm (59 in)	/	115 l (4 ft ³)	57 kg (125.6 lbs)	C890268
Humidification kit for Sweeper 110	/	/	100 l (27 gal)	40 kg (88 lbs)	C890991
Humidification kit for Sweeper 120	/	/	70 l (18,5 gal)	20 kg (44 lbs)	C890222
Humidification kit for Sweeper 150	/	/	140 l (37 gal)	40 kg (88 lbs)	C890225
Side brush for Sweeper 110		48 cm (19 in)	/	25 kg (55 lbs)	C890992
Side brush for Sweeper 120 and 150		48 cm (19 in)	/	23 kg (51 lbs)	C890226

Compatibility	1.1	2.3	4.2	5.2	5.3	6.3	7.2	8.4	8.5	11.6	11.9	EZ5	EZ7 EZ8
Model													
110													
120													
150													

Very compatible

Compatible

Not compatible

LEAF VACUUM

<http://tiny.cc/leafvacuum>



FEATURES & BENEFITS

- Powerful vacuum
- Rotary side brush
- 5 m (16 ft) hand hose available
- Easy emptying thanks to hydraulic door opening from driver seat



This attachment creates tremendous suction for collecting leaves, grass clippings, and other loose debris in parks, lawns, yards, etc. The right rotary side brush extends the cleaning area. The leaf vacuum is equipped with a floating system and four adjustable wheels that allow to work well on uneven surfaces too. The suction mouth is made of plastic material that can absorb even small impacts.

The option hand held hose allows you to clean tight work areas, flower beds, along fences, and many other hard-to-reach locations.

The leaf vacuum is equipped with a hydraulically opening door on the box floor for easy disposal of the collected debris into a container, trailer, etc.. It requires low maintenance and cleaning is quick and easy.

Note: the floating boom valve on the machine is suggested.

Model	Hose Ø	Hose Length	Width	Volume	Suction Capacity	Weight	Code
Leaf vacuum	/	/	100 cm (39.4 in)	300 l (10.6 ft ³)	50 m ³ /min (1800 ft ³ /min)	155 kg (342 lbs)	C890239
Hose	18 cm (7 in)	5 m (16 ft)	/	/	/	/	C890245
Right side brush 48 cm (18.9 in) nylon							included

Compatibility	1.1	2.3	4.2	5.2	5.3	6.3	7.2	8.4	8.5	11.6	11.9	EZ5	EZ7 EZ8
	Very compatible						Compatible			Not compatible			



WEED BRUSH

<http://tiny.cc/weedbrush>



FEATURES & BENEFITS

- Brush with steel bristles
- Powerful hydraulic motor
- Manual angle adjustment

A hydrostatic drive motor, adjustable tilt, and a specially designed brush are combined to create an effective system to remove weed and plant growth for pavement joints.

The brush angle adjustment allows easy cleaning along walkway edges or along and in wall areas.

The weed brush is an effective tool for cleaning walkways, bike paths, car parks, school yards, general sweeping and even frozen ice and snow, making this a very flexible addition to your maintenance fleet.

It is equipped with a safety guard to prevent the projection of objects. The brush sticks out of the right side of the machine.

Note: the floating boom valve on the machine is suggested.



Model	Brush diameter	Weight	Code
Weed brush 75	75 cm (29.5 in)	84 kg (185 lbs)	C890270

Compatibility	1.1	2.3	4.2	5.2	5.3	6.3	7.2	8.4	8.5	11.6	11.9	EZ5	EZ7 EZ8
	Very compatible						Compatible				Not compatible		



DEBRIS AND LEAF BLOWER

<http://tiny.cc/debrisblower>



FEATURES & BENEFITS

- 360 degree 12V nozzle rotation from operators position
- Nozzle options for specific applications
- Heavy-duty frame construction

The debris and leaf blower provides great air volume flow and the capability to rotate the nozzle 360 degrees from the operator's seat.

This blower provides superior productivity and greater efficiency in jobs ranging from cleaning sidewalks, streets, car parking and other maintained paved areas, to blowing grass clippings, leaves, snow, sand or other debris off fairways or greens. Short rectangular nozzle is standard and several nozzles are also available as option.

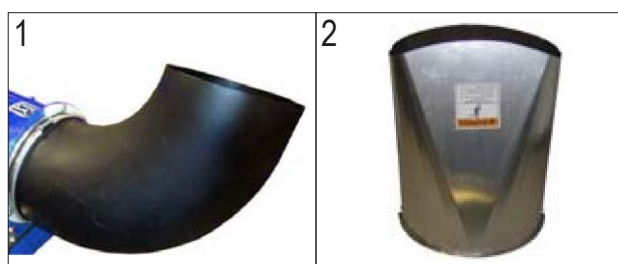

Model	Dimensions with Nozzle (LxWxH)	Weight	Code
Debris and leaf blower	163 x 117 x 82 cm (64 x 46 x 32 in)	136 kg (300 lbs)	C892000
Options			
1 90° polymer nozzle		3 kg (6.6 lbs)	C892001
2 Long rectangular nozzle end		3 kg (6.6 lbs)	C892002

Compatibility	1.1	2.3	4.2	5.2	5.3	6.3	7.2	8.4	8.5	11.6	11.9	EZ5	EZ7 EZ8
					Very compatible				Compatible			Not compatible	



SOLAR PANEL WASHER

<http://tiny.cc/solarpanelwasher>

FEATURES & BENEFITS

- Large autonomy
- New non scratch bristles
- Two spray bars (12+12 nozzles)
- New floating system

The MultiOne solar panel washer is designed to clean photovoltaic solar panels and help to maintain and optimize the performance. Utilizing the solar panel washer ensures that solar panels are not losing up to 17% – 25% of power generation due to the accumulation of dirt, dust, and other foreign matter

The big rotary broom with soft bristle let you clean about 4,3 meters quickly, effectively, and without damaging the solar panels. The solar panel washer can clean from 0,7 MW/h to 2 MW/h depending on surface type. The solar panel washer is supplied with two spray bars each with 12 nozzles. Two different types of nozzles with different flow rates are supplied (0,58 l/min-0,15 GPM and 0,65 l/min-0,17 GPM). Also supplied are 12 caps to close the nozzles. The more nozzles that close, the greater the tank autonomy (from 33 min to 1 hour and 12 min).

The rotary broom can be rotated to allow easy and quick cleaning of many rows of solar panel arrays. The new floating system avoids damage to the solar panels and grants an overall better cleaning.

Note: machine must be equipped with ACI.

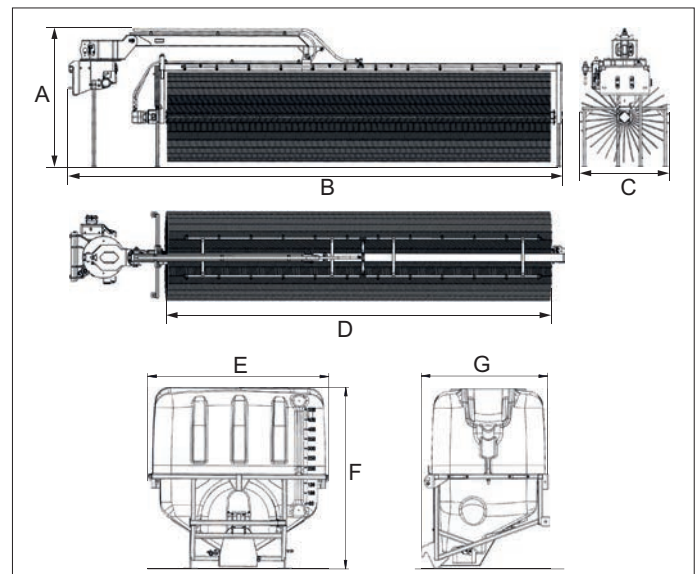

		Dimensions						
		A	B	C	D	E	F	G
cm		155	552	96	430	120	122	85
in		61	217	38	170	47	48	33

Model	Brush Length	Tank capacity	Rotation angle	Weight	Code
Solar panel washer	430 cm (170 in)	/	180°	440 kg (970 lbs)	C891293
Tank	/	500 l (132 gal)	/	100 kg (220 lbs)	C891289
Brush extension	+80 cm (32 in)	/	/	17 kg (38 lbs)	C891294
Brush counterweights (9.5 kg x 3 pieces)				29 kg (64 lbs)	C890995
Main soft brush				30 kg (66 lbs)	C890996
Extension soft brush (C891294 required)				3 kg (6.6 lbs)	C890997

Compatibility	1.1	2.3	4.2	5.2	5.3	6.3	7.2	8.4	8.5	11.6	11.9	EZ5	EZ7 EZ8
	Very compatible				Compatible				Not compatible				

MULTI ONE

ROTARY SWEEPER

<http://tiny.cc/rotarybroom>



FEATURES & BENEFITS

- Remotely controlled hydraulic angle adjustment
- Long lasting bristle material
- Equipped with extendable supports for storage: nylon brush doesn't get damaged during storing
- Direct drive transmission, low maintenance

Dirt, dried mud, light snow and other debris are quickly and efficiently swept away this hydraulically driven attachment. Whether you're sweeping driveways, farm yards or warehouses, you can rely on the rotary broom to get the job done right.

The brush can be hydraulically tilted 30° both on the right and on the left comfortably from the driver's seat. There are two adjustable wheels that keep the height of the brush constant from the ground and an elastic joint able to absorb small shocks avoiding possible damages.

The sweeper is equipped with supports which can be extended when the sweeper is not in use, so that the sweeper rests on the supports and the nylon brush doesn't get damaged during storage. Combined with a MultiOne machine with fully cab it is the right attachment for the autumn and winter maintenance. **Note: the floating boom valve on the machine is suggested.**



Model	Brush Diameter	Brush Material	Brush Width	Brush Width at Max Angle	Weight	Code
130	60 cm (23.6 in)	nylon	130 cm (51.2 in)	113 cm (44.5 in)	160 kg (353 lbs)	C890241
160	60 cm (23.6 in)	nylon	160 cm (63 in)	139 cm (54.7 in)	190 kg (419 lbs)	C890242

Compatibility	1.1	2.3	4.2	5.2	5.3	6.3	7.2	8.4	8.5	11.6	11.9	EZ5	EZ7 EZ8
Model													
130													
160													

Very compatible
 Compatible
 Not compatible



SNOW BLADE

<http://tiny.cc/snowblade>



FEATURES & BENEFITS

- Efficient on larger areas, but compact enough to clear smaller spaces
- Shock absorbing system
- 30° Slewing angle

An excellent tool to quickly clear light or moderate snow from sidewalks and driveways. Equipped with shock absorbing system that allows the blade to trip forward when an obstacle is encountered, saving wear and tear on the blade and MultiOne. It is equipped with a plastic edge that once worn out can be reversed or replaced. The blade can be hydraulically tilted 30° both to the right and to the left comfortably from the driver's seat. It is equipped with supports which can be extended when the attachment is not in use. It can be used also to move light materials such as grains or sawdust. In winter, installed on a MultiOne machine with a fully enclosed cab, it is a winning choice.

Note: the floating boom valve on the machine is suggested.



Model	Width	Blade height	Slewing angle	Blade Width at Max Angle	Weight	Code
140	140 cm (55 in)	53 cm (20.8 in)	±30°	121 cm (47.6 in)	121 kg (267 lbs)	C891303
180	180 cm (71 in)	58 cm (22.8 in)	±30°	156 cm (61.4 in)	170 kg (375 lbs)	C891304
210	210 cm (83 in)	70 cm (27.6 in)	±30°	182 cm (71.6 in)	191 kg (421 lbs)	C891305

Compatibility	1.1	2.3	4.2	5.2	5.3	6.3	7.2	8.4	8.5	11.6	11.9	EZ5	EZ7 EZ8
Model													
140													
180													
210													

Very compatible
 Compatible
 Not compatible



SNOW PLOW

<http://tiny.cc/snowplow1>

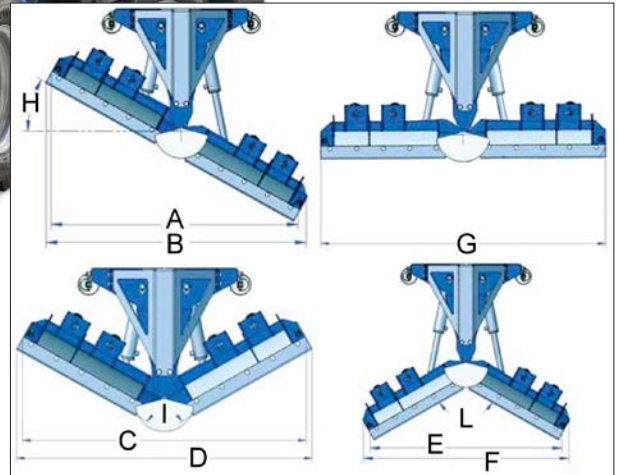

FEATURES & BENEFITS

- Rugged professional grade snow plow
- 5 configurations
- Two independent controllable blades: can be adjusted in straight, V or Y position
- Advanced optional floating system allows working on uneven surfaces as well

MultiOne snow plow is a versatile attachment for snow removal. It consists of two independent hydraulically adjustable blades. Angle of the blades can be adjusted from the driver's seat. 5 different blade operating positions:

1) 30° right - 2) 30° left - 3) Straight - 4) Scoop "Y" - 5) V-plow. It is equipped with shock absorbing springs that allow the blade to trip forward when an obstacle is encountered. The optional floating system on the mounting bracket guarantees that blade follows the ground as well as possible. Support legs are standard while the extension wings are optional; both increase the blade width.

Note: the floating boom valve on the machine is suggested.

Dimensions (cm/in)										
Model	A	B	C	D	E	F	G	H	I	L
120-126	111 43.5	120 47	121 47.6	126 49.6	100 39.4	113 44.5	127 50	29°	121°	121°
150-170	147 57.7	153 60.2	157 61.8	157 61.8	136 53.5	149 58.7	169 66.3	29°	121°	121°
200-230	198 78	207 81.3	207 81.3	213 83.7	190 74.8	200 78.7	229 90	29°	121°	121°



C891320

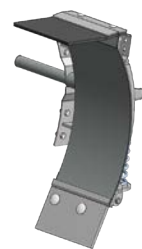

C891326

Model	Blades Width	Blades height	Slewing angle	Weight	Code
120-126	120-126 cm (47.2-49.6 in)	75 cm (29.5 in)	±30°	320 kg (705 lbs)	C891301
150-170	150-170 cm (59-67 in)	75 cm (29.5 in)	±30°	350 kg (772 lbs)	C891302
200-230	200-230 cm (78.7-90.5 in)	75 cm (29.5 in)	±30°	420 kg (926 lbs)	C891310
Options					Code
Floating Adapter for Snow Plow					C891320
Extension Wings 25 + 25 cm (9.8 + 9.8 in) only for C891301 and C891302					C891326

Compatibility	1.1	2.3	4.2	5.2	5.3	6.3	7.2	8.4	8.5	11.6	11.9	EZ5	EZ7 EZ8
Model													
120-126													
150-170													
200-230													

Very compatible
 Compatible
 Not compatible



SNOW BLOWER

<http://tiny.cc/snowblower>



FEATURES & BENEFITS

- Efficient two-stage snow blower
- Heavy duty frame and transmission with replaceable cutting edge

The snow blower is an efficient attachment to remove large volumes of snow from sidewalks, roads, or other large areas when snow needs to be spread out evenly. The two-stage blower is a powerful and efficient snow removal tool, even if the snow is wet and heavy. To achieve this efficiency, the auger breaks up the snow and the fan throws the snow out of the discharge chute. The chute can be rotated 200° (±100°) and also the discharge chute height angle can be adjusted from the operator's seat. It is equipped with adjustable skids, to set the working height, and a tool to remove snow blocks.

Note: the floating boom valve on the machine is suggested.

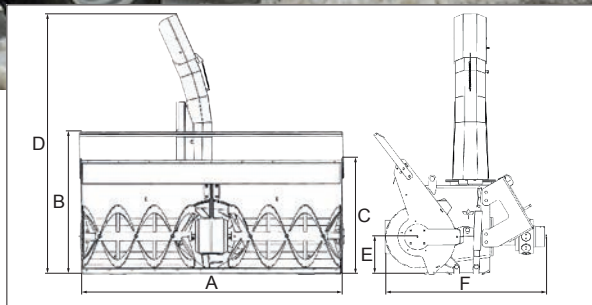

Dimensions (cm/in)						
Mod.	A	B	C	D	E	F
100	107/42	/	70/27.5	115/45.3	23/9	75/29.5
100HD	116/46	94/37	65/26	144/57	/	98/38.5
120	121/47.6	/	72/28.3	116/45.7	23/9	75/29.5
130	146/57.4	94/37	64/25.2	143/56.3	28/11	98/38.5
140	140/55	/	80/31.5	/	/	/
160	160/63	89/35	71/28	163/64.2	24/9.5	99/39
180	180/71	89/35	71/28	163/64.2	24/9.5	99/39

Model	Width	Chute rotation	Weight	Code
100	100 cm (39.4 in)	200° (±100°)	70 kg (154 lbs)	C890453
100 HD (Heavy Duty) - ACI required	100 cm (39.4 in)	200° (±100°)	290 kg (640 lbs)	C891343
120	120 cm (47.2 in)	200° (±100°)	145 kg (320 lbs)	C890454
130 HD (Heavy Duty) - ACI required	130 cm (51.2 in)	200° (±100°)	314 kg (692 lbs)	C891342
140	140 cm (55.1 in)	200° (±100°)	220 kg (485 lbs)	C890455
160 HD (Heavy Duty)	160 cm (63.0 in)	200° (±100°)	250 kg (551 lbs)	C890460
180 HD (Heavy Duty)	180 cm (70.9 in)	200° (±100°)	280 kg (618 lbs)	C890466

Compatibility	1.1	2.3	4.2	5.2	5.3	6.3	7.2	8.4	8.5	11.6	11.9	EZ5	EZ7 EZ8
Model													
100	Not compatible	Very compatible	Very compatible	Very compatible	Very compatible	Very compatible	Very compatible	Very compatible	Very compatible	Very compatible	Very compatible	Not compatible	Not compatible
120	Not compatible	Very compatible	Very compatible	Very compatible	Very compatible	Very compatible	Very compatible	Very compatible	Very compatible	Very compatible	Very compatible	Not compatible	Not compatible
100 HD	Not compatible	Very compatible	Very compatible	Very compatible	Very compatible	Very compatible	Very compatible	Very compatible	Very compatible	Very compatible	Very compatible	Not compatible	Not compatible
140	Not compatible	Very compatible	Very compatible	Very compatible	Very compatible	Very compatible	Very compatible	Very compatible	Very compatible	Very compatible	Very compatible	Not compatible	Not compatible
130 HD - 160 HD	Not compatible	Very compatible	Very compatible	Very compatible	Very compatible	Very compatible	Very compatible	Very compatible	Very compatible	Very compatible	Very compatible	Not compatible	Not compatible
180 HD	Not compatible	Very compatible	Very compatible	Very compatible	Very compatible	Very compatible	Very compatible	Very compatible	Very compatible	Very compatible	Very compatible	Not compatible	Not compatible

Very compatible Compatible Not compatible

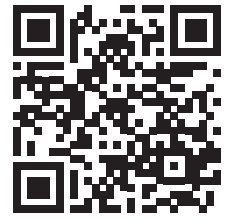

SALT AND SAND SPREADER

<http://tiny.cc/saltspreader>

FEATURES & BENEFITS

- Fast and reliable attachment
- Rubber cover included
- 180° spread angle
- Available as either an attachment plate mount or as a towed unit.
- Multi sector limiter available for more precise spreading
- The attachment plate mounted unit has a hydraulically powered spinner
- The tow behind units spinner plate is powered by an axle mounted planetary gear

This unit is an ideal winter time tool to spread ice control products on parking lots and pedestrian areas. The towed version, combined with a snow blade or a snow turbine, allows to clear snow and spread anti-ice products simultaneously. Can also be used in the warmer months to spread seed and fertilizer.

The discharge pattern is easily set with a lever adjusted professional spread limiter.



Model	Volume	Max load ⁽¹⁾	Max Spreading Width Granular	Max Spreading Width Crystalline	Weight	Code
Towed centrifugal ⁽²⁾	200 l (7 ft ³)	200 kg (441 lbs)	12 – 14 m (39 – 46 ft)	6 – 7 m (20 – 23 ft)	80 kg (176 lbs)	C890186
Centrifugal stainless steel	200 l (7 ft ³)	200 kg (441 lbs)	12 – 14 m (39 – 46 ft)	6 – 7 m (20 – 23 ft)	54 kg (119 lbs)	C890185

(1) verify the lifting capacity of the machine. (2) Trailer coupling is required.

Options

	Code
Professional stainless steel deflector	C890187

Compatibility	1.1	2.3	4.2	5.2	5.3	6.3	7.2	8.4	8.5	11.6	11.9	EZ5	EZ7 EZ8
Model													
Towed centrifugal													
Centrifugal stainless steel													

Very compatible

Compatible

Not compatible

DROP SPREADER

<http://tiny.cc/dropsreader>



FEATURES & BENEFITS

- Self-loading design.
- Adjustable stop springs for salt distribution, present throughout the entire length of the system.
- Distributor roller: the pegs are positioned in helical position to assure a continuous and proportioned distribution.
- Protective netting: a protective metallic mesh net is fixed on the top of the salt loading vat.
- Internal mixer axle which breaks frozen salt and prevents the salt from clogging up.



The drop spreader is designed for fast and efficient spreading. Front mounting allows loading from ground level in the same way as with normal bucket. Powered by hydraulic motor and equipped with a mixer axle which breaks frozen salt and prevents the salt from clogging up. It is ideal to spread salt or sand on parking lots, sidewalks, bicycle lanes and pedestrian areas.

Model	Volume*	Width	Spreading Width	Height	Weight	Code
110	470 l (16.6 ft ³)	125 cm (49.2 in)	110 cm (43.3 in)	100 cm (39.4 in)	270 kg (595 lbs)	C890189
130	580 l (20.5 ft ³)	145 cm (57 in)	130 cm (51 in)	100 cm (39.4 in)	330 kg (728 lbs)	C890188

(*) verify the lifting capacity of the machine

Compatibility	1.1	2.3	4.2	5.2	5.3	6.3	7.2	8.4	8.5	11.6	11.9	EZ5	EZ7 EZ8
Model													
110													
130													

Very compatible
 Compatible
 Not compatible



TRAILER

<http://tiny.cc/trailerrimorchio>



FEATURES & BENEFITS

- Robust and versatile dump trailer, ideal for earthmoving and other lighter duty jobs
- Manual or hydraulic tipping
- Removable sides

MultiOne trailer is useful for transporting garden waste, top soil, mulch, etc. Equipped with pintle a style hitch and parking brake. Available with either manual or hydraulic dump system.

- 600 model: manual rear tipping, foldable rear side, parking brake, support leg for parking.
 - 1200 and 1500 model: hydraulic rear tipping, foldable side and rear sides, parking brake, third wheel for parking, two manual winches. The 1200 model is equipped with road lights and seven pin standard plug.
- Attention: the loader must be equipped with the trailer coupling and with the rear single hydraulic outlet to drive the hydraulic tipping and.



Model	Max Load	Length	Width	Sides Height	Tipping	Wheels	Weight	Code
600	450 kg (992 lbs)	150 cm (59 in)	115 cm (45.3 in)	35 cm (13.8 in)	manual	16-6.50-8	150 kg (331 lbs)	C890770
1200	870 kg (1918 lbs)	200 cm (78.7 in)	140 cm (55.2 in)	35 cm (13.8 in)	hydraulic	185/70 R13	330 kg (728 lbs)	C890775
1500	980 kg (2160 lbs)	220 cm (86.6 in)	150 cm (59 in)	35 cm (13.8 in)	hydraulic	205/70 R15	520 kg (1146 lbs)	C890776

Compatibility	1.1	2.3	4.2	5.2	5.3	6.3	7.2	8.4	8.5	11.6	11.9	EZ5	EZ7 EZ8
Model													
600													
1200													
1500													

Very compatible
 Compatible
 Not compatible



HIGH PRESSURE WASHER

<http://tiny.cc/highpressurewasher>



FEATURES & BENEFITS

- Efficient high pressure and self contained washer system
- Equipped with a hand held spray wand with a 10 m (33 ft) hose

High pressure washer is perfect for cleaning construction sites and general maintenance. The powerful 170 bar (2,465 psi) pressure jet cleans dirt, built up and dry mud, waxes, oils, grease, strips old paint, and more from any surface.

This pressure washer system, combined with the on-board 200 l (53 gal) water tank, makes cleaning buildings and graffiti removal an efficient process. It is possible to regulate the water pressure, the tank is equipped with a filter and a level indicator. The hand held spray has an adjustable nozzle to set the water jet width.

Using MultiOne's hydraulic power and portability, this self contained pressure washer system effectively works in remote locations where electricity or water are not available.



Model	Pressure	Volume*	Hydraulic power	Pipe length	Weight	Code
High pressure washer	170 bar	200 l (52.8 gal)	35 l/min (9.2 GPM)	/	75 kg (166 lbs)	C891200
Hand spray wand (included)		/	/	10 m (32.8 ft)	/	/

(* verify the lifting capacity of the machine)

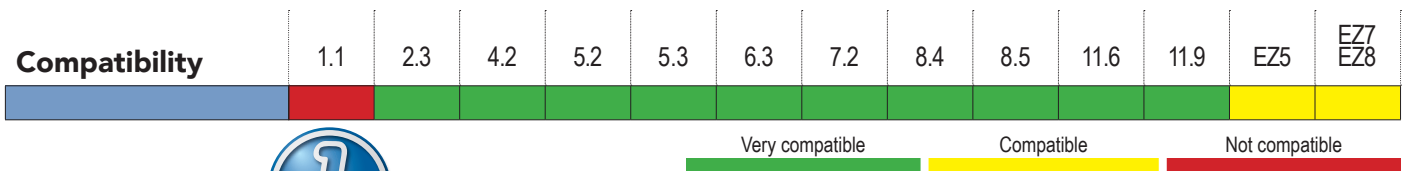

STAKE INSTALLER

<http://tiny.cc/stakeinstaller>



FEATURES & BENEFITS

- Efficient and time saving
- Powerful attachment

The stake installer attachment lets you use your MultiOne mini loader to rapidly drive stakes into the ground with minimal ground preparation. The specially designed tool holds a fence stake while a hydraulically powered vibratory hammer pounds the stake into the ground. The MultiOne boom enables the efficient handling of long stakes.

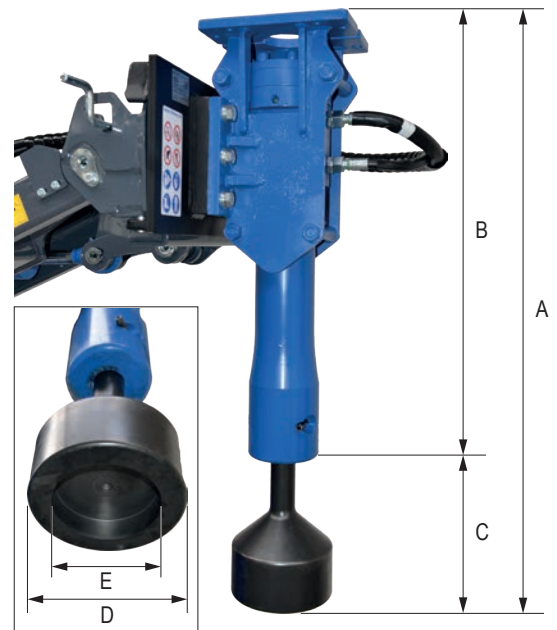

		Dimensions				
		A	B	C	D	E
cm		98	74	24	18	12
in		38.6	29.1	9.5	7	4.7

Model	Impact energy	Impact rate	Ø Tool	Weight	Code
Stake installer	190 J	1000/1300 bpm	45 mm (1,8 in)	120 kg (265 lbs)	C890780

Compatibility	1.1	2.3	4.2	5.2	5.3	6.3	7.2	8.4	8.5	11.6	11.9	EZ5	EZ7 EZ8
	Very compatible				Compatible				Not compatible				



AERIAL WORK PLATFORM

<http://tiny.cc/aerialworkplatform>



FEATURES & BENEFITS

- Safe and legal way to do building repairs, painting, light bulb changes etc.
- MultiOne carries the platform anywhere
- Independent from external power source
- The maximum allowed load on the basket is 120 kg and it is possible to use the lift alone.



The MultiOne aerial work platform is attached to the MultiOne by the coupling plate. This makes it fast and easy to mount it on and take it off. Thanks to the small size and the maneuverability of MultiOne machines it is possible to reach even the most inaccessible work sites. This portable platform is suitable for building repairs, painting, light bulb replacement, general maintenance and more. The safe working load for the aerial work platform is 120 kg (265 lbs), which makes it ideal for one man and plenty of tools. This platform is a cost effective system that enables reaching working heights up to 9,8 m (32 ft). The platform is equipped with four adjustable support legs for stabilization even on very rough and not perfectly flat surfaces. It can be operated either directly from the basket or from the ground (in case of emergency). There is a safety valve that can be operated to bring the basket back to the ground in the event of a power failure.

Model	Platform height	Lift Capacity	Basket size	Working height	Total dimensions	Weight	Code
PID 10	7,8 m (25,6 ft)	120 kg (265 lbs)	65x65 cm (25.6x25.6 in)	9,8 m (32 ft)	130x70 cm (51.2x27.5 in)	350 kg (772 lbs)	C895151

Compatibility	1.1	2.3	4.2	5.2	5.3	6.3	7.2	8.4	8.5	11.6	11.9	EZ5	EZ7 EZ8
	Very compatible	Not compatible	Compatible	Compatible	Very compatible	Very compatible	Very compatible	Very compatible	Very compatible	Very compatible	Very compatible	Compatible	Compatible



STREET WASHER

<http://tiny.cc/streetwasher>



FEATURES & BENEFITS

- High water pressure
- The spray bars can be tilted up at 90°
- Includes a hand spray wand with 10 m (32 ft) hose on a storage reel
- High capacity tank

MultiOne Street Washer is the best solution for quickly cleaning public roads, town centers, car parks, market squares, large industrial areas, resort walkways, and wherever hygiene is required. The Street Washer combines low water consumption and high water flow and pressure. High pressure water takes dust, sand and debris out of asphalt, concrete and similar surfaces and doesn't therefore emit dust after drying. Low water consumption and high capacity tank make possible to clean larger areas with a single pass. The Street Washer is equipped with two foldable nozzle bars for street cleaning and a hand held washing gun with 10 m (32 ft) hose. The tank is equipped with a level indicator, a filter and a small separate water tank with a tap useful to wash the hands.



Model	Spray Bar Width	Tank Capacity*	Water pressure	Nozzles	Hose Length	Weight	Code
300	150 cm (59 in)	300 l (79.2 gal)	150 bar	3	/	60 kg (132 lbs)	C890750
600	250 cm (98.4 in)	600 l (158.5 gal)	150 bar	5	/	75 kg (165 lbs)	C890751
Hand spray wand					10 m (32.8 ft)	/	included

(* verify the lifting capacity of the machine)

Compatibility	1.1	2.3	4.2	5.2	5.3	6.3	7.2	8.4	8.5	11.6	11.9	EZ5	EZ7 EZ8
Model													
300	Very compatible	Compatible	Compatible	Compatible	Compatible	Compatible	Compatible	Compatible	Compatible	Compatible	Compatible	Compatible	Compatible
600	Very compatible	Compatible	Compatible	Compatible	Compatible	Compatible	Compatible	Compatible	Compatible	Compatible	Compatible	Compatible	Compatible

Very compatible Compatible Not compatible



FLAIL MOWER WITH SIDE SHIFT

<http://tiny.cc/flailmowerside>



ACI ATTACHMENT CONTROL INTERFACE

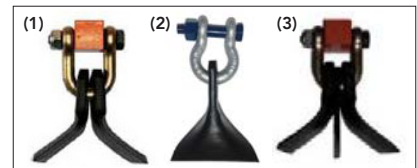

FEATURES & BENEFITS

- Hydraulic side shift and angle control flail mower
- Powerful attachment
- Equipped with direct drive hydraulic motor
- ACI: control all movements on a fingertip

Use this hydraulically powered flail mower with side shift for heavy shrubs and weeds, and see what it can do! Not only is its heavy duty construction, combined with the power and stability of the MultiOne, perfect for use on slopes, but it's also perfect for mulching in parks and other hard to reach places. Features:

- 1) Standard in-line front flail mower.
- 2) Offset length (174 cm / 68.5 in).
- 3) To -45° angle ditch mower.
- 4) To +90° angle bank and hedge mower.

Y blades ⁽¹⁾ comes standard, it can be equipped with Paddle Blades ⁽²⁾ (C035307) or Verticut ⁽³⁾ (C035312 + Y blade).

Notes: machine must be equipped with ACI.

The floating boom valve on the machine is suggested.

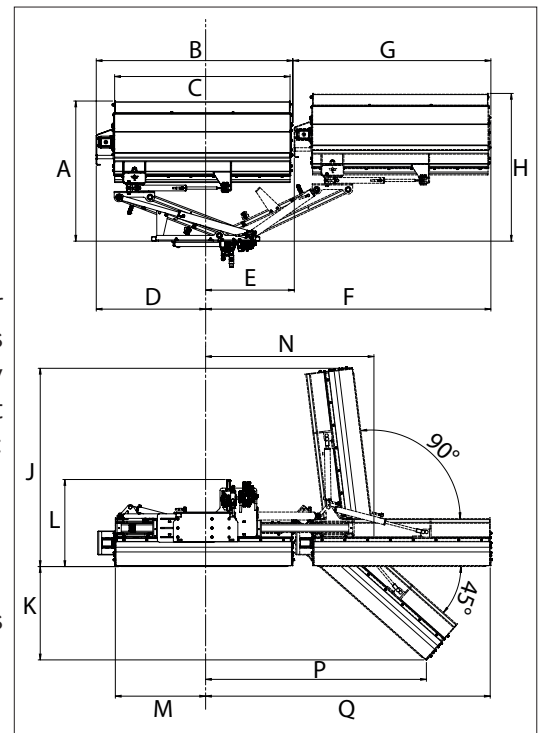

Dimensions (cm / in)

Mod.	A	B	C	D	E	F	G	H	J	K	L	M	N	P	Q
110	123	128	109	96	78	205	174	130	129	53	76	79	148	159	215
	48.4	50.2	42.9	37.8	30.6	80.9	68.4	51	51	20.7	30	31.2	58.1	62.7	84.6
125	123	143	124	96	78	220	174	130	144	63	76	79	148	170	230
	48.4	56.1	48.8	37.8	30.6	86.8	68.4	51	56.8	24.6	30	31.2	58.1	67.1	90.5

Model	Cutting Width	Tools	Rotation Angle	Max Side Shift	Weight	Code
110	100 cm (39.4 in)	20	+90° / - 45°	174 cm (68.5 in)	277 kg (610 lbs)	C890785
125	115 cm (45.3 in)	24	+90° / - 45°	174 cm (68.5 in)	300 kg (662 lbs)	C890786

Compatibility	1.1	2.3	4.2	5.2	5.3	6.3	7.2	8.4	8.5	11.6	11.9	EZ5	EZ7 EZ8
Model													
110													
125													

Very compatible
 Compatible
 Not compatible



FLAIL MOWER

<http://tiny.cc/flailmower1>



FEATURES & BENEFITS

- Hydraulic motor mounted directly on the shaft
- Multifloat® system: allows free vertical and orizzontal movement
- Bigger roller in the rear: better stability and less resistance when mowing
- Longer and wider skid shoes on the sides.

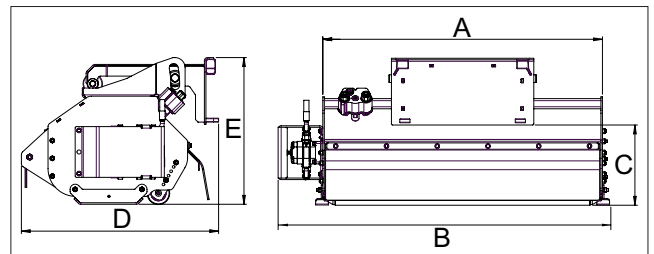

Mod.	Dimensions (cm/in)				
	A	B	C	D	E
96	96 / 37.8	107 / 42	40 / 15.7	87 / 34	65 / 25.6
115	115 / 45.3	120 / 47	40 / 15.7	87 / 34	65 / 25.6
125	125 / 49.2	133 / 52	40 / 15.7	87 / 34	65 / 25.6
155	155 / 61	173 / 68	32 / 12.5	78 / 30.6	58 / 22.8

Flail mower is a drum-type cutter, intended for cutting of long grass, scrub, bush and similar vegetation. It will cut up to 20 mm thick tree branches with ease.

Flail mower is the optimal cutting device for places where you need a lot of cutting power and a rougher cut will do. The most common applications for flail mower are places with taller vegetation like meadows, road banks, yard areas etc. This mower capitalizes on MultiOne's best in class hydraulic power to deliver top performance. Y blades ⁽¹⁾ comes standard, it can be equipped with Hammer Blades ⁽²⁾ or Verticut ⁽³⁾ only for 155 model (C890619). **Note: the floating boom valve on the machine is suggested.**

The most common applications for flail mower are places with taller vegetation like meadows, road banks, yard areas etc. This mower capitalizes on MultiOne's best in class hydraulic power to deliver top performance. Y blades ⁽¹⁾ comes standard, it can be equipped with Hammer Blades ⁽²⁾ or Verticut ⁽³⁾ only for 155 model (C890619). **Note: the floating boom valve on the machine is suggested.**

Model	Cutting Width	Cutting Height	Tools	Weight	Code
96	93 cm (36.6 in)	3-12 cm (0.8-4.7 in)	32	150 kg (330 lbs)	C891355
115	106 cm (41.7 in)	3-12 cm (0.8-4.7 in)	32	160 kg (353 lbs)	C891356
125	119 cm (46.8 in)	3-12 cm (0.8-4.7 in)	40	175 kg (386 lbs)	C891357
155	145 cm (57 in)	2-10 cm (0.8-4 in)	32	162 kg (357 lbs)	C890619
Hammer blades kit for flail mower 96			16	/	C890655
Hammer blades kit for flail mower 115			16	/	C890656
Hammer blades kit for flail mower 125			24	/	C890657
Hammer blade for flail mower 155 (1 pcs)					C035307
Verticut blade for flail mower 155 (1 pcs)					C035312

Compatibility	1.1	2.3	4.2	5.2	5.3	6.3	7.2	8.4	8.5	11.6	11.9	EZ5	EZ7 EZ8
Model													
96	Not compatible	Very compatible	Compatible	Compatible	Compatible	Compatible	Compatible	Compatible	Compatible	Compatible	Compatible	Not compatible	Not compatible
115	Not compatible	Very compatible	Compatible	Compatible	Compatible	Compatible	Compatible	Compatible	Compatible	Compatible	Compatible	Not compatible	Not compatible
125	Not compatible	Very compatible	Compatible	Compatible	Compatible	Compatible	Compatible	Compatible	Compatible	Compatible	Compatible	Not compatible	Not compatible
155	Not compatible	Very compatible	Compatible	Compatible	Compatible	Compatible	Compatible	Compatible	Compatible	Compatible	Compatible	Not compatible	Not compatible

Very compatible Compatible Not compatible



HEAVY DUTY FLAIL MOWER

<http://tiny.cc/HDflailmower>



FEATURES & BENEFITS

- Heavy duty tools
- Perfect for thick grass, sticks, undergrowth and pruning residues, roadside maintenance
- New floating system

The Heavy Duty flail mower is now stronger and more powerful for maintaining rugged landscape areas such as heavy grasses, storm debris, sticks, pruning residues and more around farms, properties, parklands, and roadsides.

The hammer ⁽¹⁾ shaft set-up is especially designed to withstand to heavy works, such as cutting shrubs up to a diameter of 5 cm.

The rear support roller, adjustable in height, make this tool extremely effective and allow the operator to choose the desired cutting height.

The new floating system permits to follow the ground contours in an effective way also on uneven lawns.

Note: the floating boom valve on the machine is suggested.

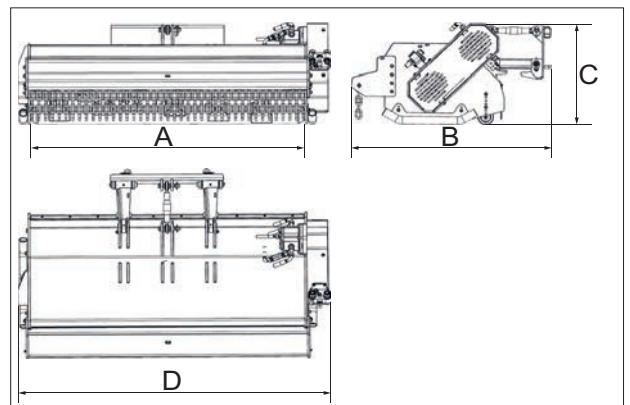
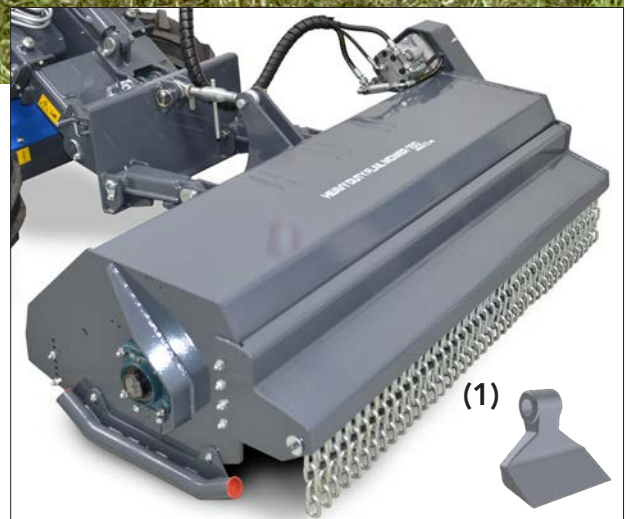

Dimensions (cm/in)			
A	B	C	D
150 / 59	115 / 45	61 / 24	179 / 70

Model	Cutting Width	Cutting Height	Hammers 120 mm	Weight	Code
150	150 cm (59 in)	1-10 cm (0.4-4 in)	18	470 kg (1036 lbs)	C890540

Compatibility	1.1	2.3	4.2	5.2	5.3	6.3	7.2	8.4	8.5	11.6	11.9	EZ5	EZ7 EZ8
	Very compatible	Compatible	Compatible	Compatible	Compatible	Compatible	Compatible	Compatible	Compatible	Compatible	Compatible	Not compatible	Not compatible



SIDE BOOM WITH FLAIL MOWER DZ2

<http://tiny.cc/sideflailmower>



FEATURES & BENEFITS

- Excellent visibility of the whole working area
- Compact with long reach capabilities
- ACI: control all movements on a fingertip

MultiOne's side flail mower lets reach the cutting head into waterfronts, ditches, steep slopes, and other hard to reach areas safely. This mower uses lets you choose between two flail mowers for tough brush.

The DZ2 model is suitable for mounting on MultiOne machines, from series 8 to 11.

Y blades ⁽¹⁾ comes standard, it can be equipped with Paddle Blades ⁽²⁾ (C035307 for flail mower 80 - C890655 for flail mower 96) or Verticut ⁽³⁾ (C035312 + Y blade - only for flail mower 80).

Notes: machine must be equipped with ACI.
the floating boom valve on the machine is suggested.

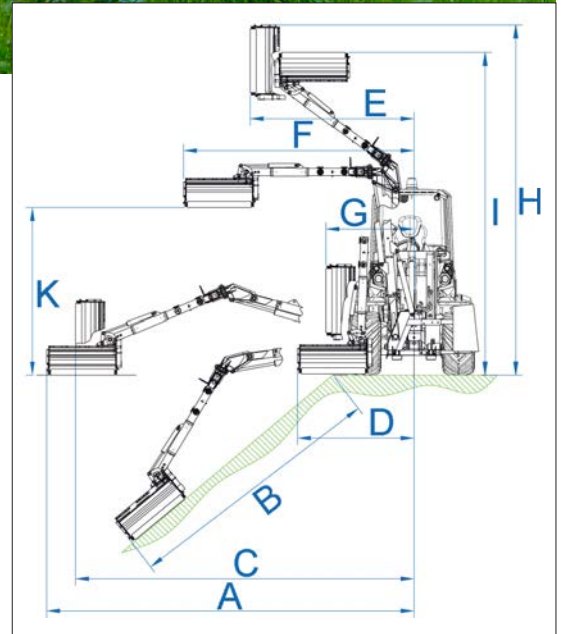

Dimensions (cm / in)										
Model	A	B	C	D	E	F	G	H	I	K
Flail mower 80	315 124	190 74.8	265 104.3	185 72.8	155 61	215 84.6	135 53.1	375 147.6	325 128	135 53.1
Flail mower 96	335 132	210 82.7	265 104.3	205 80.7	155 61	235 92.5	135 53.1	395 155.5	325 128	135 53.1

Boom Mower	Max. Extension	Cutting Width	Tools	Weight	Code
Boom mower DZ2(*)	3,35 m (11 ft)	/	/	486 kg (1072 lbs)	C890609
Flail mower 80 for boom	/	80 cm (31.5 in)	16	105 kg (232 lbs)	C890611
Flail mower 96 for boom	/	93 cm (36 in)	32	150 kg (330 lbs)	C890784

(*) C890611 or C890784 required

Compatibility	1.1	2.3	4.2	5.2	5.3	6.3	7.2	8.4	8.5	11.6	11.9	EZ5	EZ7 EZ8
Model													
Boom + 80 Flail mower													
Boom + 96 Flail mower													

Very compatible Compatible Not compatible



TORNADO LAWN MOWER

<http://tiny.cc/tornadolawnmower2>



FEATURES & BENEFITS

- Powerful lawn mower with internal clipping catcher
- Can also be used to collect tree leaves on lawns
- New floating system guarantees easy operation and good mowing result also on uneven lawns
- Low noise emissions and not dust
- Rounded edges - less damage to trees, buildings etc. in case of contact
- Automatic stop valve - stops the blades when the Tornado is lifted off the ground



Designed for professional level green space maintenance, the MultiOne Tornado mower with the internal clipping catcher effectively cuts dry and wet grass. Using the patented MultiOne Tornado, in a single pass you can cut, pick-up, and collect the clippings in the internal catcher with no noise or dust. The blades of the mower crush the grass clippings, leaves etc. into a very fine material which then moves to the collector. The cutting waste is ideal material for composting. Collector capacity is as big as 250 litres, which enables cutting of small to medium sized areas. Emptying of the collector is very easy: lift the mower up from the ground with MultiOne's boom and then tilt the mower downward so much that the grass waste pushes the lid open and the waste comes out. The collector can be easily unloaded directly into a trailer. Thanks to its excellent suction power collecting of leaves from the lawns is also possible.

Note: the floating boom valve on the machine is suggested.

Model	Cutting Width	Volume*	Cutting height	Blades	Weight	Code
Tornado 130	130 cm (51 in)	250 l (8.8 ft ³)	2,5-12 cm (1 – 5 in)	4 (2+2)	290 kg (640 lbs)	C891350
Tornado 160	160 cm (63 in)	250 l (8.8 ft ³)	2,5-12 cm (1 – 5 in)	4 (2+2)	320 kg (705 lbs)	C891351

(* verify the lifting capacity of the machine)

Compatibility	1.1	2.3	4.2	5.2	5.3	6.3	7.2	8.4	8.5	11.6	11.9	EZ5	EZ7 EZ8
Model													
130													
160													

Very compatible
 Compatible
 Not compatible



LAWN MOWER

<http://tiny.cc/lawnmower2>



FEATURES & BENEFITS

- Equipped with automatic stop valve
- Floating system guarantees easy operation and good mowing result also on uneven lawns
- Rear or side discharge as standard, mulching kit available as an option
- Four puncture free tires

Ideal for fine cut applications, such as golf courses and large acreage mowing. The mower has been designed with three blades (two blades on mod. 100) that cut with an overlap which prevents uncut strips.

MultiOne's extensive design experience makes the mower very reliable and assures a high quality cut. The independent four wheels support of the mower frame allows the mower deck to follow ground contours. It is equipped with floating system, which guarantees optimal touch with the ground also on uneven lawns. The mower is also equipped with an automatic stop valve which blocks the blades when the mower is lifted off the ground. Moreover, thanks to the MultiOne telescopic boom, it is possible to cut the grass even under trees and bushes where the conventional mowers could not reach. The mower mod. 100 is mulching type as standard. Mulching kit is available as an option on models 120, 150 and 180.

Note: the floating boom valve on the machine is suggested.

Model	Width	Cutting Height	Weight	Code
Lawn mower 100 with mulching system	100 cm (39.4 in)	1-12 cm (0.4 – 5 in)	116 kg (256 lbs)	C895081
Lawn mower 120 with right side discharge	120 cm (47.2 in)	2-9 cm (0.8 – 3.6 in)	190 kg (419 lbs)	C891360
Lawn mower 150 with right side discharge	150 cm (59 in)	1-12 cm (0.4 – 5 in)	207 kg (457 lbs)	C890980
Lawn mower 180 with right side discharge	180 cm (70.8 in)	2-9 cm (0.8 – 3.6 in)	246 kg (542 lbs)	C891362
Options				
Mulching kit for lawn mower 120			20 kg (44 lbs)	C891363
Mulching kit for lawn mower 150			21 kg (47 lbs)	C890633
Mulching kit for lawn mower 180			25 kg (55 lbs)	C891365

Compatibility	1.1	2.3	4.2	5.2	5.3	6.3	7.2	8.4	8.5	11.6	11.9	EZ5	EZ7 EZ8
Model													
100	Very compatible	Very compatible	Very compatible	Very compatible	Very compatible	Very compatible	Very compatible	Not compatible	Not compatible	Not compatible	Not compatible	Not compatible	Not compatible
120	Not compatible	Compatible	Compatible	Compatible	Compatible	Compatible	Compatible	Compatible	Compatible	Compatible	Compatible	Not compatible	Not compatible
150	Not compatible	Not compatible	Not compatible	Not compatible	Compatible	Compatible	Compatible	Compatible	Compatible	Compatible	Compatible	Not compatible	Not compatible
180	Not compatible	Not compatible	Not compatible	Not compatible	Not compatible	Not compatible	Not compatible	Compatible	Compatible	Compatible	Compatible	Not compatible	Not compatible

Very compatible Compatible Not compatible



SPIKE AERATOR

<http://tiny.cc/spikeaerator>

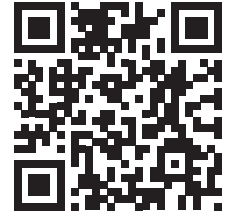

FEATURES & BENEFITS

- Quick and efficient operation
- Suitable for sandy or loamy soils
- Equipped with knife type blades

The spike aerator is completely mechanical and it cuts and penetrates the ground surface using the wedge shaped spikes. The cut slots enable air, fertilizer and water to effectively reach the lawn roots in sandy or loamy soils. The open slots quickly close after water causes the compacted soil to expand.

Spike penetration depth is easily controlled using the two guide wheels, providing consistent results.

The spike aerator is also equipped with mechanical support legs which lift the blades off the ground for storage.

It is the ideal attachment for gardens and sports fields maintenance where MultiOne machines, thanks to their traction system, don't damage the turf.

Note: the floating boom valve on the machine is suggested.



Model	Working Width	Max Working Depth	Weight	Code
Spike Aerator	130 cm (51.2 in)	10 cm (4 in)	300 kg (662 lbs)	C890446

Compatibility	1.1	2.3	4.2	5.2	5.3	6.3	7.2	8.4	8.5	11.6	11.9	EZ5	EZ7 EZ8



Very compatible
 Compatible
 Not compatible

CORE AERATOR

<http://tiny.cc/coreaerator>

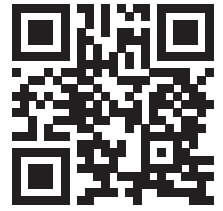

FEATURES & BENEFITS

- Holes stay open for a long time
- Suitable for heavy clay soils

The core aerator penetrates the ground pulling plugs of grass and soil from the ground, leaving the plugs behind. The holes created enable air, fertilizer, and water to effectively reach the lawn roots in heavy clay soils.

Core aerator penetration depth is easily controlled using the two guide wheels, providing consistent results. The core aerator is also equipped with mechanical support legs which lift the blades off the ground for storage. It is the ideal attachment for gardens and sports fields maintenance where MultiOne machines, thanks to their traction system, don't damage the turf.

Note: the floating boom valve on the machine is suggested.



Model	Working Width	Max Working Depth	Weight	Code
Core Aerator	130 cm (51.2 in)	10 cm (4 in)	300 kg (662 lbs)	C890445

Compatibility	1.1	2.3	4.2	5.2	5.3	6.3	7.2	8.4	8.5	11.6	11.9	EZ5	EZ7 EZ8



HEDGE CUTTER

<http://tiny.cc/hedgecutter>

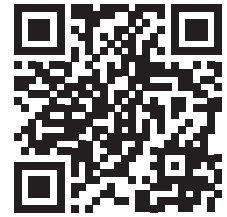

FEATURES & BENEFITS

- Cut angle electrically adjustable
- Time saving attachment
- Very high cutting quality
- Cutting bar is suitable for cutting fine leaves, as well as heavy growth

The hedge cutter is the perfect attachment for hedge cutting. The combination of the cutter arm angle adjustment and the MultiOne's boom provides excellent reach. Through using the speed and flexibility of MultiOne machines, cutting straight hedge profiles is quick and easy. Cutting bars available with 1 cm (0.4 in) or 3 cm (1.2 in) max. Cutting branches diameter Max. side shift 45 cm (17.7 in).

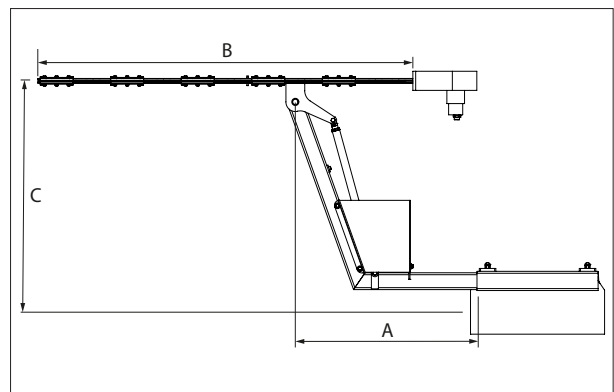

Mod.	Dimensions (cm/in)			
	A (min)	A (max)	B	C
10 - 160	35/13.8	80/31.5	160/63	100/39
30 - 160	35/13.8	80/31.5	160/63	100/39
10 - 210	35/13.8	80/31.5	210/83	100/39

Model	Hedge cutter length	Max. cutting diameter	Slewing angle	Weight	Code
Frame only (C890666, C890667 or C890668 required)	/	/	/	47 kg (104 lbs)	C890665
Hedge cutter 10 - 160 (C890665 required)	160 cm (63 in)	1 cm (0.4 in)	120°	34 kg (75 lbs)	C890666
Hedge cutter 30 - 160 (C890665 required)	160 cm (63 in)	3 cm (1.2 in)	120°	40 kg (88 lbs)	C890667
Hedge cutter 10 - 210 (C890665 required)	210 cm (83 in)	1 cm (0.4 in)	120°	44 kg (97 lbs)	C890668

Compatibility	1.1	2.3	4.2	5.2	5.3	6.3	7.2	8.4	8.5	11.6	11.9	EZ5	EZ7 EZ8
Model													
Hedge cutter 10 - 160													
Hedge cutter 30 - 160													
Hedge cutter 10 - 210													

Very compatible
 Compatible
 Not compatible



SICKLE BAR MOWER

<http://tiny.cc/sicklebarmower1>



FEATURES & BENEFITS

- Robust and economical long hay cutter
- Compact dimensions
- Cost effective
- Fast

The MultiOne hydraulically powered sickle bar mower has been designed to quickly and effectively cut long grasses and hay on fields, meadows, and road banks.

Thanks to its small size it is easily transportable and can be used in hard-to-reach areas.

It is equipped with two blades, one fixed and one mobile.

The sickle bar mower is ideal for cutting these grasses which can be harvested in a secondary process.

It is equipped with two adjustable skids to set the cutting height.

Note: the floating boom valve on the machine is suggested.



Model	Width	Weight	Code
145	145 cm (57 in)	83 kg (183 lbs)	C890653
165	165 cm (65 in)	93 kg (205 lbs)	C890654

Compatibility	1.1	2.3	4.2	5.2	5.3	6.3	7.2	8.4	8.5	11.6	11.9	EZ5	EZ7 EZ8
Model													
145	Very compatible	Compatible	Very compatible	Very compatible	Very compatible	Very compatible	Very compatible	Very compatible	Very compatible	Very compatible	Very compatible	Very compatible	Very compatible
165	Very compatible	Very compatible	Very compatible	Very compatible	Very compatible	Very compatible	Very compatible	Very compatible	Very compatible	Very compatible	Very compatible	Very compatible	Very compatible

Very compatible Compatible Not compatible



LANDSCAPE POT CLAMP

<http://tiny.cc/vaseclamp>



FEATURES & BENEFITS

- The easiest way to lift and transport potted or balled plants, trees, barrels, and more without causing damage.
- Excellent tool for nurseries and landscapers

The MultiOne pot clamp is designed to lift and transport round objects, such as potted or balled plants and trees, barrels, and more without causing damage. Grabbing force can be adjusted by a valve, which means all kinds of objects can be handled without damaging them. It is the ideal attachment for the nurseryman who, thanks to the small size of the Multione machine, can transport both the plant pots and the machine on the truck or trailer to make the unloading at the delivery place simply and quickly.

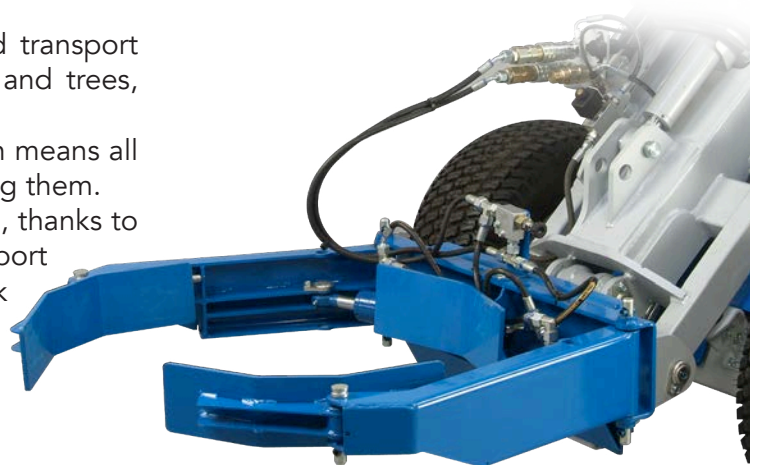

Model	Max load	Min Opening	Max Opening	Weight	Code
Landscape pot clamp	650 kg (1433 lbs)	25 cm (9.8 in)	120 cm (47.2 in)	80 kg (176 lbs)	C890721

Compatibility	1.1	2.3	4.2	5.2	5.3	6.3	7.2	8.4	8.5	11.6	11.9	EZ5	EZ7 EZ8



TELESCOPIC SIDE ARM M1-15

<http://tiny.cc/sidearmm1-15>

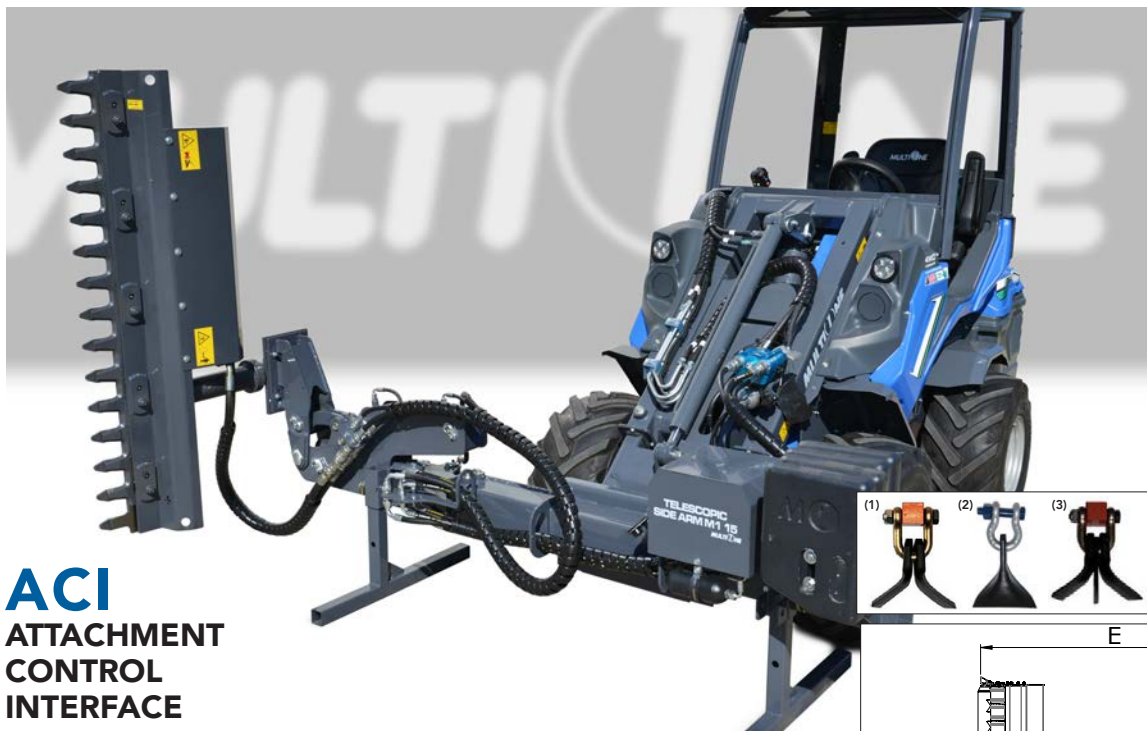

ACI ATTACHMENT CONTROL INTERFACE

FEATURES & BENEFITS

- Outreach to side up to 3,72 m
- Easy mowing or trim on the right side
- ACI: control all movements on a fingertip

The telescopic side arm is equipped with a straight telescopic arm and a tilting jib arm. The telescopic arm extends 1,05 m hydraulically to the side, and the jib arm movement is 45° down and 90° up from the horizontal position.

The attachment, mounted on the side arm, will give in backward when it hits an obstacle. The side arm will come back to normal position as soon as the obstacle is out of the way.

The flail mower comes standard with Y blades ⁽¹⁾, it can be equipped with Paddle Blades ⁽²⁾ (C035307 for flail mower 80 - C890655 for flail mower 96) or Verticut ⁽³⁾ (C035312 + Y blade - only for flail mower 80).

MultiOne rear side weight C883077 it is mandatory.

Note: machine must be equipped with ACI.

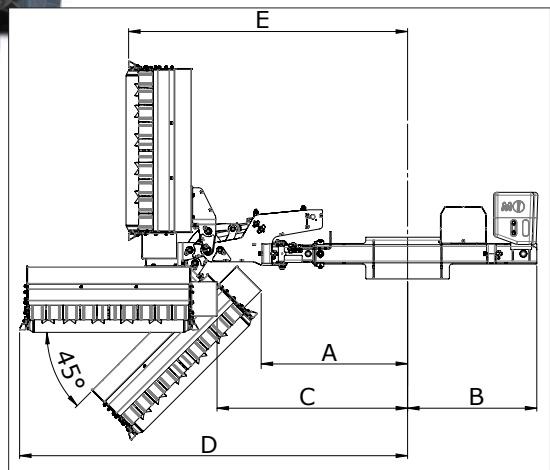

Dimensions (cm / in)			
	C890611	C890784	C890950
A	98-203 / 38.5-80	102-207 / 40-81.5	
B	87 / 34.5		
C	128-233 / 50.5-91.5	117-222 / 46-87.5	
D	240-345 / 94.5-135.8	260-365 / 102.5-143.5	267-372 / 105-146.5
E	187-292 / 73.5-115		162-267 / 64-105

Model	Max. Offset	Cutting Width	Max. cutting diameter	Tools	Weight	Code
Telescopic Side Arm M1-15 (*)	105 cm (41.5 in)	/	/	/	250 kg (551 lbs)	C890551
1 Branch cutting bar 150 (**)	/	150 cm (59 in)	5 cm (2 in)	/	155 kg (342 lbs)	C890950
2 Flail mower 80 (**)	/	80 cm (31.5 in)	2 cm (0.8 in)	16	105 kg (232 lbs)	C890611
3 Flail mower 96 (**)	/	93 cm (36 in)	2 cm (0.8 in)	32	150 kg (330 lbs)	C890784
Options						
Rear side weights 160 kg	/	/	/	/	160 kg (352 lbs)	C883077

(*) C890950 or C890611 or C890784 required

(**) C890551 and C883077 required

Compatibility	1.1	2.3	4.2	5.2	5.3	6.3	7.2	8.4	8.5	11.6	11.9	EZ5	EZ7 EZ8
M1-15 with:													
Branch cutting bar 150													
Flail mower 80/96													

Very compatible Compatible Not compatible



ARTICULATED SIDE ARM M1-30

<http://tiny.cc/sidearmm1-30>

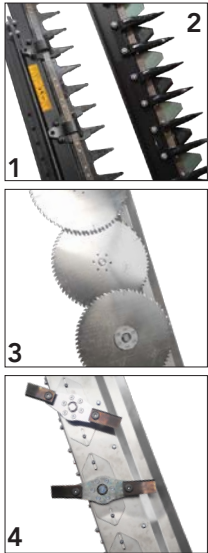

ACI
ATTACHMENT
CONTROL
INTERFACE

FEATURES & BENEFITS

- Cut on both sides
- Four cutting options
- **ACI control: all movements on a fingertip**

Compact, light and maneuverable, the articulated side arm M1-30 has been designed for contractors, municipalities and estate managers working in landscape and ground-care sectors. From grass cutting to tree trimming, the articulated side arm M1-30 can do this thanks to the different end tools like Hedge cutter, Hedge trimmer, and Flail mower.

It's the ideal reach mower to operate in very narrow spaces for hedge trimming or mowing with the freedom to cut on both sides of the MultiOne compact loader.

Note: machine must be equipped with ACI

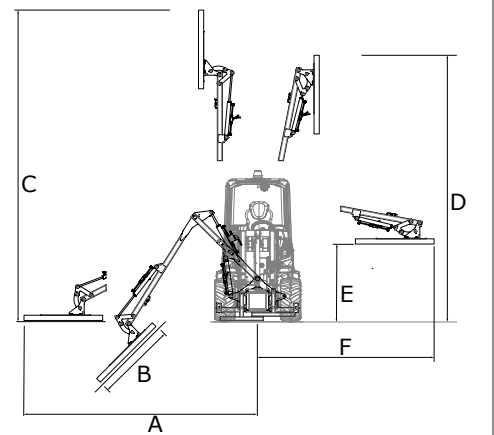

Dimensions (cm / in)			
	C890666	C890667	C890671
A	273/107	322/127	301/119
B	247/97	270/106	237/93
C	437/172	414/163	419/165
D	440/173	380/150	367/145
E	115/45	115/45	76/30
F	311/122	290/114	236/93

Model	Max. Extension	Cutting Width	Max. cutting diameter	Tools	Weight	Code
Articulated Side Arm M1-30 ⁽¹⁾	3 m (9.8 ft)	/	/	/	192 kg (423 lbs)	C890940
1 Hedge cutter 10 - 160 ⁽²⁾	/	160 cm (63 in)	1 cm (0.4 in)	/	34 kg (75 lbs)	C890666
	Hydraulic hoses kit for hedge cutter 10-160 (required)					C890695
2 Hedge cutter 30 - 160 ⁽²⁾	/	160 cm (63 in)	3 cm (1.2 in)	/	40 kg (88 lbs)	C890667
	Hydraulic hoses kit for hedge cutter 30-160 (required)					C890695
3 Cutting discs bar 140 ⁽³⁾	/	140 cm (55 in)	/	4	100 kg (220 lbs)	C890671
4 Blade kit ⁽⁴⁾ (option for cutting discs bar 140)			/	8	/	C890673

(1) C890666 or C890667 or C890671 required - (2) C890940 and C890695 required - (3) C890940 required - (4) C890671 required

Compatibility	1.1	2.3	4.2	5.2	5.3	6.3	7.2	8.4	8.5	11.6	11.9	EZ5	EZ7 EZ8
M1-30 with:													
Hedge cutter 10 - 160	Not compatible	Not compatible	Compatible	Compatible	Compatible	Compatible	Compatible	Compatible	Compatible	Compatible	Compatible	Compatible	Compatible
Hedge cutter 30 - 160	Not compatible	Not compatible	Compatible	Compatible	Compatible	Compatible	Compatible	Compatible	Compatible	Compatible	Compatible	Compatible	Compatible
Cutting discs bar 140	Not compatible	Not compatible	Compatible	Compatible	Compatible	Compatible	Compatible	Compatible	Compatible	Compatible	Compatible	Compatible	Compatible

Very compatible Compatible Not compatible



SPRAYER

<http://tiny.cc/sprayer>



FEATURES & BENEFITS

- Fast application for large areas
- Adjustable flow and pressure
- Foldable spray bar
- Equipped with a hand held spray wand with a 50 m (165 ft) hose

The hydraulically powered MultiOne sprayer is the proper attachment for the fast and efficient application of landscaping chemicals. **NOTE: MultiOne recommends that the operator wears the appropriate personal protection equipment while handling and applying landscaping chemicals.**

The foldable 4,5 m (14.75 ft) wide spray bar, combined with the 120 l (31.7 US gal) tank allow for fast coverage of large areas. Spray nozzles are replaceable and adjustable to assure the proper material application, making this system ideal for landscapes and grass areas maintenance.

This unit comes standard with a 50 m (165 ft) hose reel with an application wand and nozzle. It is also possible to reach the most inaccessible places, such as the tree tops. System pressure and flow are adjustable to meet application requirements. There are an filter and a small separate water tank with a tap useful to wash the hands.



Model	Capacity*	Max Pressure	Spraying Bar Width - Opened	Spraying Bar Width - Closed	Hose reel	Weight	Code
Sprayer	120 l (31.7 gal)	40 bar	450 cm (177.2 in)	150 cm (59 in)	50 m (164 ft)	65 kg (144 lbs)	C890740

(* verify the lifting capacity of the machine)

Compatibility	1.1	2.3	4.2	5.2	5.3	6.3	7.2	8.4	8.5	11.6	11.9	EZ5	EZ7 EZ8
	Very compatible							Compatible			Not compatible		



STRING SHOOT REMOVER

<http://tiny.cc/shootremover>



FEATURES & BENEFITS

- Low wear cutter string
- Variable offset (+-25 cm)
- Efficient and reliable

The MultiOne shoot remover is an ideal tool for the removal of weeds and plant shoots from around trees. Hydraulically powered, it gently removes the shoots without causing tree trunk damage.

The shoot remover frame can be offset to the right to allow for variable working conditions. Replacement of the long lasting rubber strings is quick and easy.

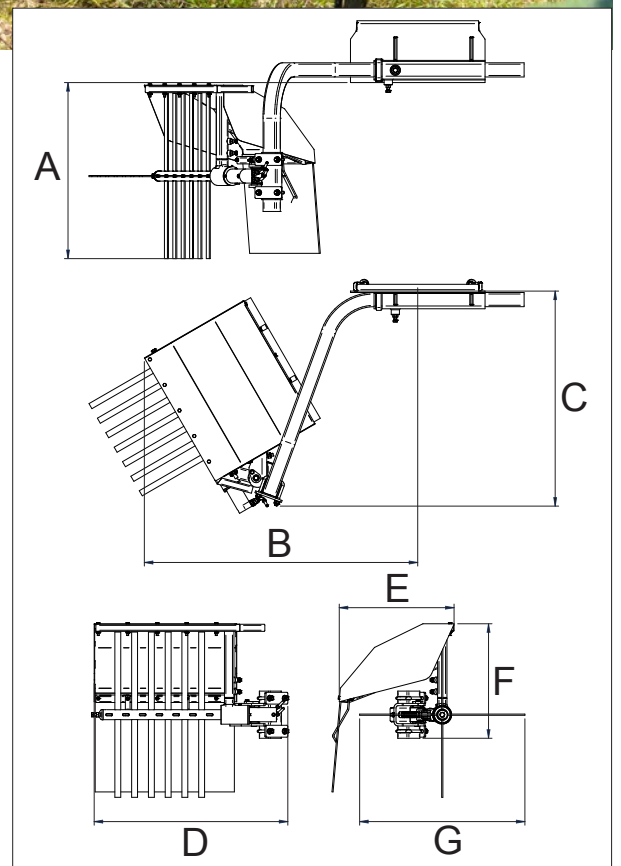

Dimensions (cm/in)						
A	B	C	D	E	F	G
75	116	91	82	49	49	70
29.4	45.7	35.8	32.3	19.3	19.3	27.6

Model	Rotor Length	Offset Max	Weight	Code
String shoot Remover	52 cm (20 in)	141 cm (55.5 in)	50 kg (110 lbs)	C890436

Compatibility	1.1	2.3	4.2	5.2	5.3	6.3	7.2	8.4	8.5	11.6	11.9	EZ5	EZ7 EZ8
	Very compatible						Compatible			Not compatible			



DUAL BLADE HEDGE TRIMMER

<http://tiny.cc/Vineyardtrimmer>



FEATURES & BENEFITS

- Dual cutting action saves time
- Completely adjustable
- Easy to control

The hydraulically powered dual blade hedge trimmer allows the top and sides of vine rows and large plants to be cut simultaneously. Each frame and cutter assembly is independently adjustable, and MultiOne's boom provides additional flexibility and control. The inclination of the horizontal cutting bar can be adjusted manually and there is an electric actuator which allows the simultaneous adjustment of the inclination of both cutting bars directly from the driver's seat. It is equipped with support legs to position it during periods of non-use.

The frame can be offset to the right (max. 40 cm - 15.7 in) to allow for variable working conditions.

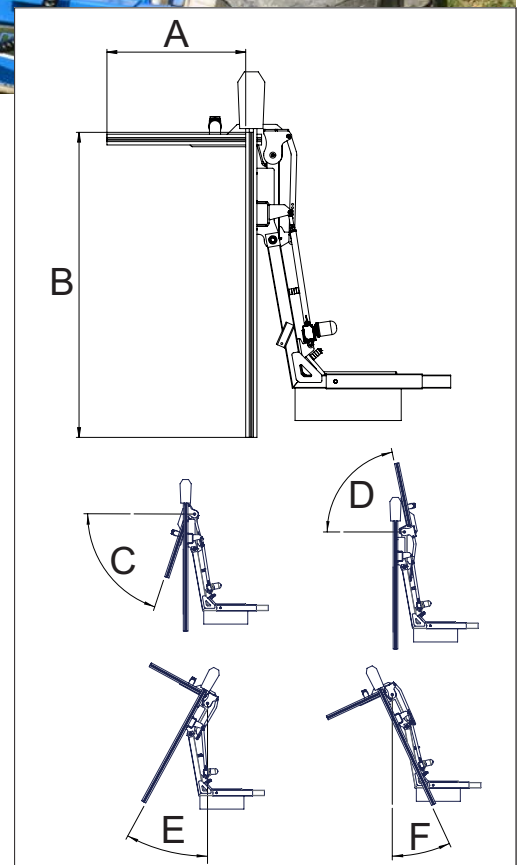

Dimensions (cm/in)					
A	B	C	D	E	F
74	160	71°	78°	28°	25°
29	63				

Model	Vertical Bar Length	Horizontal Bar Length	Max Right Side Shift	Max. cutting diameter	Weight	Code
Double Blade Hedge Trimmer	160 cm (63 in)	74 cm (29,1 in)	40 cm (15.7 in)	1 cm (0.4 in)	160 kg (353 lbs)	C890441

Compatibility	1.1	2.3	4.2	5.2	5.3	6.3	7.2	8.4	8.5	11.6	11.9	EZ5	EZ7 EZ8
	Very compatible							Compatible			Not compatible		



INTER-ROW MOWER

<http://tiny.cc/interrow>



FEATURES & BENEFITS

- Spring shock absorber system
- Abrasion resistant guard
- Floating system

The inter-row mower is designed to cut grass and shrubs around trees, guard rails, traffic signs, and other obstacles. The floating mower system allows the mower to automatically follow ground contours. This system provides excellent productivity and an even cut. The inter-row mower disk can be offset to the right to allow for variable working conditions. It is equipped with a hydraulic valve that prevents blades rotation inversion.

Note: the floating boom valve on the machine is suggested.

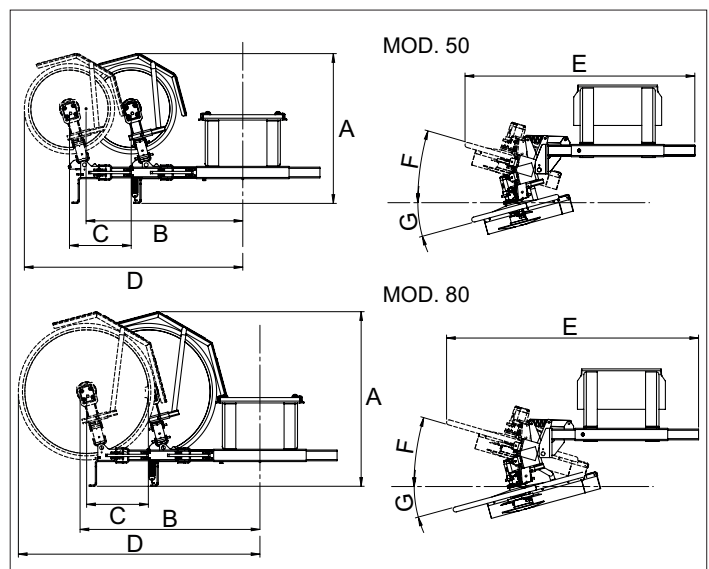

	Dimensions (cm/in)						
	A	B	C	D	E	F	G
Mod. 50	97 38.2	102 40	40 15.7	142 55.7	149 58.6	16°	15°
Mod. 80	113 44.6	117 45.9	40 15.7	157 61.6	163 64.3	16°	15°

Model	Mowing disk diameter	Max Side Shift	Nr. Blades	Weight	Code
50	48 cm (18.9 in)	40 cm (15.7 in)	2	108 kg (238 lbs)	C890705
80	80 cm (31.5 in)	40 cm (15.7 in)	2	115 kg (254 lbs)	C890706

Compatibility	1.1	2.3	4.2	5.2	5.3	6.3	7.2	8.4	8.5	11.6	11.9	EZ5	EZ7 EZ8
Model													
50													
80													

Very compatible
 Compatible
 Not compatible



TREE SHAKER WITH COLLECTOR

<http://tiny.cc/treeshaker>



FEATURES & BENEFITS

- Total control of vibration frequency (up to 40 Hz)
- Operates on trees with wide trunk
- Harvest collector 5 m (16.4 ft)
- Shaker vibrating head tiltable ($\pm 40^\circ$)

The tree shaker attachment incorporates the most advanced harvest technology for olives, almonds, nuts, pistachio, etc. The shaker requires a minimum distance of 70 cm (27 in) from the soil to the foliage. The adjustable vibration frequency maximizes the effect on the fruit, avoiding low frequency vibrations on the trunk. Depending on ground conditions, as many as 40 to 60 trees can be processed per hour. The hydraulically controlled collector has a diameter of 5 m (16.4 ft), capturing fruit from large trees and it is equipped with a hydraulically opening hatch through which is possible to unload the product collected directly on trucks or trailers.

The shaker vibrating head is powered by a compact hydraulic motor and it is tiltable to the right and to the left ($\pm 40^\circ$).

Note: machine must be equipped with ACI.

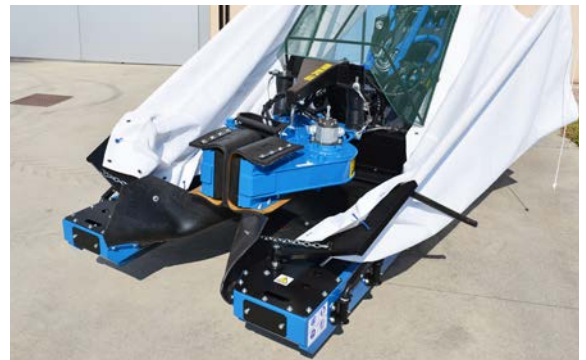

Model	Trunk diameter	Capacity*	Diameter	Weight	Code
Shaker vibrating head	0-35 cm (0-13.8 in)	/	/	330 kg (727 lbs)	C891000
Collector	/	300 kg (660 lbs)	5 m (16.4 ft)	180 kg (397 lbs)	included

(*) verify the lifting capacity of the machine

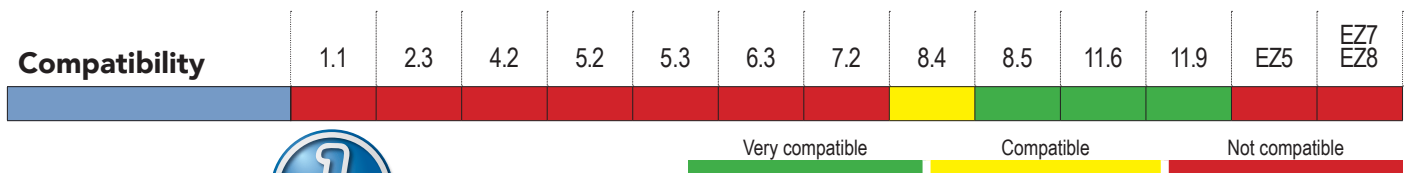

VINEYARD SPRAYER

<http://tiny.cc/vineyardsprayer>

FEATURES & BENEFITS

- High pressure, hydraulically powered pump
- Polyethylene tank
- Clean water tank for hand washing
- Equipped with a hand held spray wand with a 50 m (165 ft) hose

The Vineyard Sprayer is a versatile attachment suitable for vineyard spraying, weed-killing in open-field growing, inter-row weed-killing.

The spray bars can be rotated and adjusted in height. The nozzles are specifically designed to spray efficiently and without product waste. The high capacity tank is equipped with a level indicator and allows long work sessions without the need to stop for refueling. The pressure is adjustable; there is an anti-clogging filter and a small separate water tank, equipped with a tap, useful for washing hands.

Note: MultiOne recommends that the operator wears the appropriate personal protection equipment while handling and applying landscaping chemicals.

Model	Tank Capacity*	Nozzles	Max Pressure	Weight	Code
Vineyard Sprayer	200 l (52.8 gal)	4+4	40 bar	90 kg (198 lbs)	C890741

(* verify the lifting capacity of the machine)

Compatibility	1.1	2.3	4.2	5.2	5.3	6.3	7.2	8.4	8.5	11.6	11.9	EZ5	EZ7 EZ8
					Very compatible				Compatible			Not compatible	

VINEYARD TOOL CARRIER

<http://tiny.cc/toolcarrier>



FEATURES & BENEFITS

- Multifunction tool
- 6 professional accessories for vineyards
- Suitable for rows from 200 cm (6.5 ft) wide

MultiOne's vineyard tool carrier is a multifunctional tool carrier for a wide range of vineyard accessories.

This tool carrier for vineyard is equipped with an electro-hydraulic distributor with 4 functions (roll back / tilt head / side extension / height) operated through a joystick positioned in the operator's cab. An hydraulic system roll the tool back to avoid damages to plants. **Note: the floating boom valve on the machine is suggested.**



Model	Diameter /Blade Length	Min. Row Width	Weight	Code
Vineyard tool carrier (base machine)	/	200 cm (78.74 in)	220 kg (485 lbs)	C890760
1 Blade Weeder (*)	50 cm (19.68 in)	/	25 kg (55 lbs)	C890763
2 Plough roots bare blade (*)	26 cm (10.23 in)	/	25 kg (55 lbs)	C890766
3 Power Harrow unit 4 blades (*)	40 cm (15.74 in)	/	35 kg (77 lbs)	C890761
4 Disk roots bare (*)	36 cm (14.17 in)	/	30 kg (66 lbs)	C890764
5 Disk roots prop (*)	46 cm (18.11 in)	/	30 kg (66 lbs)	C890765
6 Disk Mower (*)	40 cm (15.74 in)	/	35 kg (77 lbs)	C890762

(*) C890760 required

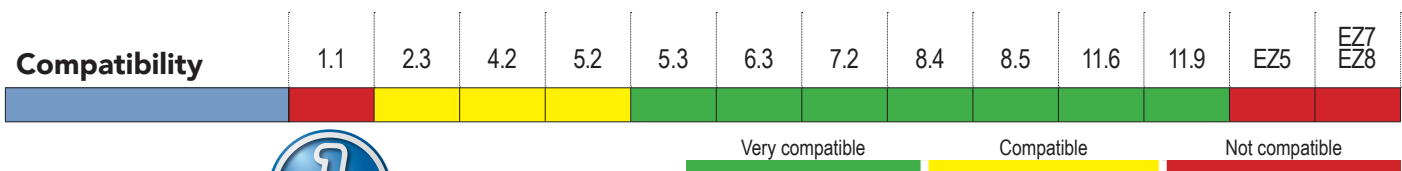

LEVELLER

<http://tiny.cc/leveller>



FEATURES & BENEFITS

- Economical attachment to level gravel and other soils
- Eliminates almost all manual shoveling and grading at job sites

A simple and inexpensive but incredibly useful and efficient attachment for levelling and planing of larger areas. With MultiOne leveller you can easily and quickly level sand, mulch etc. The leveller is most commonly used in:

- Preliminary lawn bed levelling
- Yard sand levelling
- Driveway levelling

The leveller can also be used for lifting job site light materials like sod rolls, tools etc.



Model	Width	Length	Weight	Code
Leveler	150 cm (59 in)	105 cm (41.3 in)	130 kg (287 lbs)	C890100

Compatibility	1.1	2.3	4.2	5.2	5.3	6.3	7.2	8.4	8.5	11.6	11.9	EZ5	EZ7 EZ8
	Very compatible						Compatible			Not compatible			



ROLLER

<http://tiny.cc/m1roller>

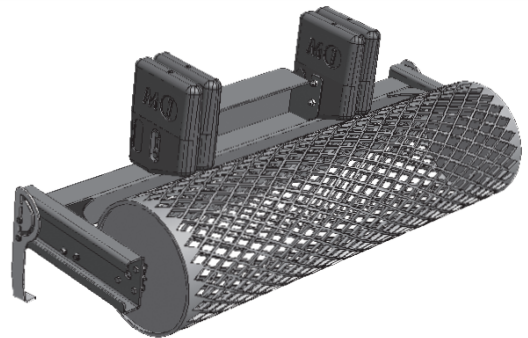
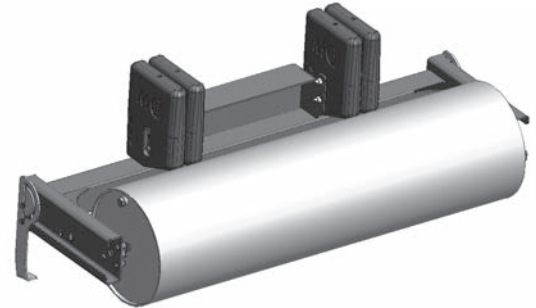

FEATURES & BENEFITS

- Perfect attachment to compact soils
- Weights can be added to increase compaction
- Two models: mesh and fillable

A simple and inexpensive but incredibly useful and efficient attachment for levelling and compacting of large areas.

Thanks to MultiOne roller it is easily and quickly to level sand, mulch etc.

The roller is most commonly used in:

- Preliminary lawn bed levelling and compaction;
- Yard sand compaction;
- Driveway levelling and compaction.

Model	Volume	Working Width	Weight	Code
Plain roller fillable	178 l (47 gal)	150 cm (59 in)	165 kg (364 lbs)	C890930
Mesh roller	/	152 cm (59.8 in)	170 kg (375 lbs)	C890931
Options				
Rear side weights 160 kg	/	/	160 kg (352 lbs)	C883077

Compatibility	1.1	2.3	4.2	5.2	5.3	6.3	7.2	8.4	8.5	11.6	11.9	EZ5	EZ7 EZ8
Model													
Plain roller fillable													
Mesh roller													

Very compatible
 Compatible
 Not compatible



RIPPER

<http://tiny.cc/ripper>



FEATURES & BENEFITS

- An inexpensive tool for removing rocks, tree stumps, roots, etc. from the ground
- Eliminates a huge amount of manual work

The ripper is an inexpensive and practically irreplaceable tool in ground works. Thanks to the ripper it is easier and effortless to remove roots as well as rocks even from hard packed ground. The ripper teeth are 30 cm (12 in) long for deep surface penetration and guarantee a long lifespan to the attachment.

The ripper is operated by pressing the three teeth into the ground next to the object you wish to remove. When the teeth have sunk into the ground, tilt the ripper inwards and then lift the boom upwards which will bring the object on top of the ground.

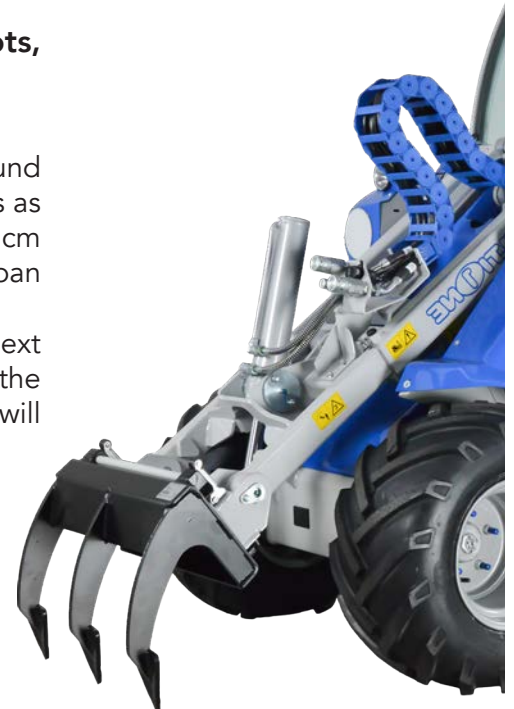

Model	Working depth	Width	Weight	Code
Ripper	30 cm (11.8 in)	50 cm (19.7 in)	23 kg (51 lbs)	C891220

Compatibility	1.1	2.3	4.2	5.2	5.3	6.3	7.2	8.4	8.5	11.6	11.9	EZ5	EZ7 EZ8
	Very compatible				Compatible				Not compatible				



ROTARY TILLER

<http://tiny.cc/rotarytiller>



FEATURES & BENEFITS

- Reliable, heavy duty
- Adjustable soil scraper blade
- Adjustable working depth

The heavy duty MultiOne rotary tiller is the ideal tool for preparing the soil for seeding or planting, even in tough conditions and hard soils. In one pass, the hydraulically powered tiller breaks up the soil, weeds and scrub growth are uprooted, and the soil is leveled.

The solid frame and the chain transmission ensure durability and reliability. The small dimensions combined with the agility of the MultiOne machines make it an ideal attachment for narrow spaces.

Note: the floating boom valve on the machine is suggested.

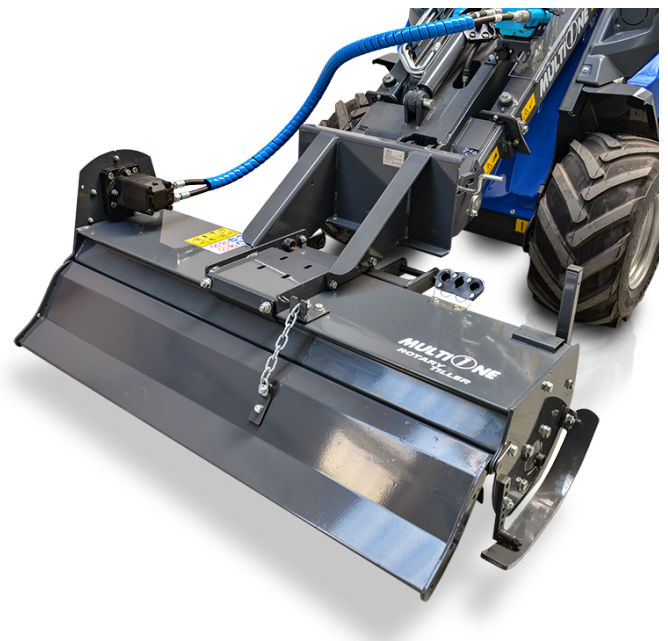

Model	Working Width	Working depth	Blades	Weight	Code
105	105 cm (41.3 in)	0 - 15 cm (0- 6 in)	20	140 kg (309 lbs)	C890490
125	125 cm (49.2 in)	0 - 15 cm (0- 6 in)	24	150 kg (331 lbs)	C890491
145	145 cm (57 in)	0 - 15 cm (0- 6 in)	28	160 kg (353 lbs)	C890492

Compatibility	1.1	2.3	4.2	5.2	5.3	6.3	7.2	8.4	8.5	11.6	11.9	EZ5	EZ7 EZ8
Model													
105	Very compatible	Very compatible	Very compatible	Very compatible	Very compatible	Very compatible	Very compatible	Very compatible	Very compatible	Very compatible	Very compatible	Not compatible	Not compatible
125	Very compatible	Compatible	Compatible	Compatible	Very compatible	Very compatible	Very compatible	Very compatible	Very compatible	Very compatible	Very compatible	Not compatible	Not compatible
145	Very compatible	Very compatible	Very compatible	Very compatible	Very compatible	Very compatible	Very compatible	Very compatible	Very compatible	Very compatible	Very compatible	Not compatible	Not compatible

Very compatible Compatible Not compatible



POWER HARROW

<http://tiny.cc/powerharrow>



FEATURES & BENEFITS

- Professional, efficient rotary harrow for topsoil levelling
- Top grade finish with just one pass
- Can be equipped with seeding unit - ready lawn surface in a single pass

MultiOne power harrow is an excellent leveler for lawn beds, yards, gardens etc. – for places where the ground needs to be perfectly levelled. It harrows only the topsoil and gives a very nice finish for sowing. Working depth is adjusted by the rear field roller that levels the seeding bed during operation.

The optional seeding unit allows to make a ready lawn surface on one pass.

Power harrow is most commonly used for lighter topsoil levelling.

Note: the floating boom valve on the machine is suggested.

Model	Working Width	Working Depth	Blades	Weight	Code
110 w/roller	110 cm (43.3 in)	0 - 18 cm (0- 7 in)	10	211 kg (465 lbs)	C890520
130 w/roller	130 cm (51.2 in)	0 - 18 cm (0- 7 in)	12	226 kg (498 lbs)	C890521
150 w/roller	150 cm (59 in)	0 - 18 cm (0- 7 in)	14	248 kg (547 lbs)	C890522
Options					
Seeding unit for power harrow 110				70 kg (154 lbs)	C890526
Seeding unit for power harrow 130				76 kg (167 lbs)	C890527
Seeding unit for power harrow 150				90 kg (198 lbs)	C890528

Compatibility	1.1	2.3	4.2	5.2	5.3	6.3	7.2	8.4	8.5	11.6	11.9	EZ5	EZ7 EZ8
Model													
110 w/roller	Very compatible	Compatible	Compatible	Compatible	Compatible	Compatible	Compatible	Compatible	Compatible	Compatible	Compatible	Not compatible	Not compatible
130 w/roller	Very compatible	Compatible	Compatible	Compatible	Compatible	Compatible	Compatible	Compatible	Compatible	Compatible	Compatible	Not compatible	Not compatible
150 w/roller	Very compatible	Compatible	Compatible	Compatible	Compatible	Compatible	Compatible	Compatible	Compatible	Compatible	Compatible	Not compatible	Not compatible

Very compatible Compatible Not compatible



POWER RAKE

<http://tiny.cc/powerrake>



FEATURES & BENEFITS

- **Powerful and fast**
- **Adjustable working depth**
- **Tiltable**

The MultiOne power rake is the ideal tool to prepare the soil for planting.

Operating the power rake with the gauge wheels down puts the machine in the landscaping mode, conditioning and preparing the soil, creating an ideal bed for seeding. Operating the power rake with the gauge wheels up puts the machine in the tilling mode for more aggressive soil preparation. It is manually tiltable to the right (17°) and to the left (21°)

Since the power rake does not require a lot of power, even the smaller machines work well with this unit.

Note: the floating boom valve on the machine is suggested.



Model	Width	Wheels Height	Weight	Code
135	135 cm (53.1 in)	0 - 8 cm (0 - 3.1 in)	250 kg (551 lbs)	C890685
155	155 cm (61 in)	0 - 8 cm (0 - 3.1 in)	290 kg (640 lbs)	C890686

Compatibility	1.1	2.3	4.2	5.2	5.3	6.3	7.2	8.4	8.5	11.6	11.9	EZ5	EZ7 EZ8
Model													
135													
155													

Very compatible
 Compatible
 Not compatible



STONE BURIER

<http://tiny.cc/stoneburrier>

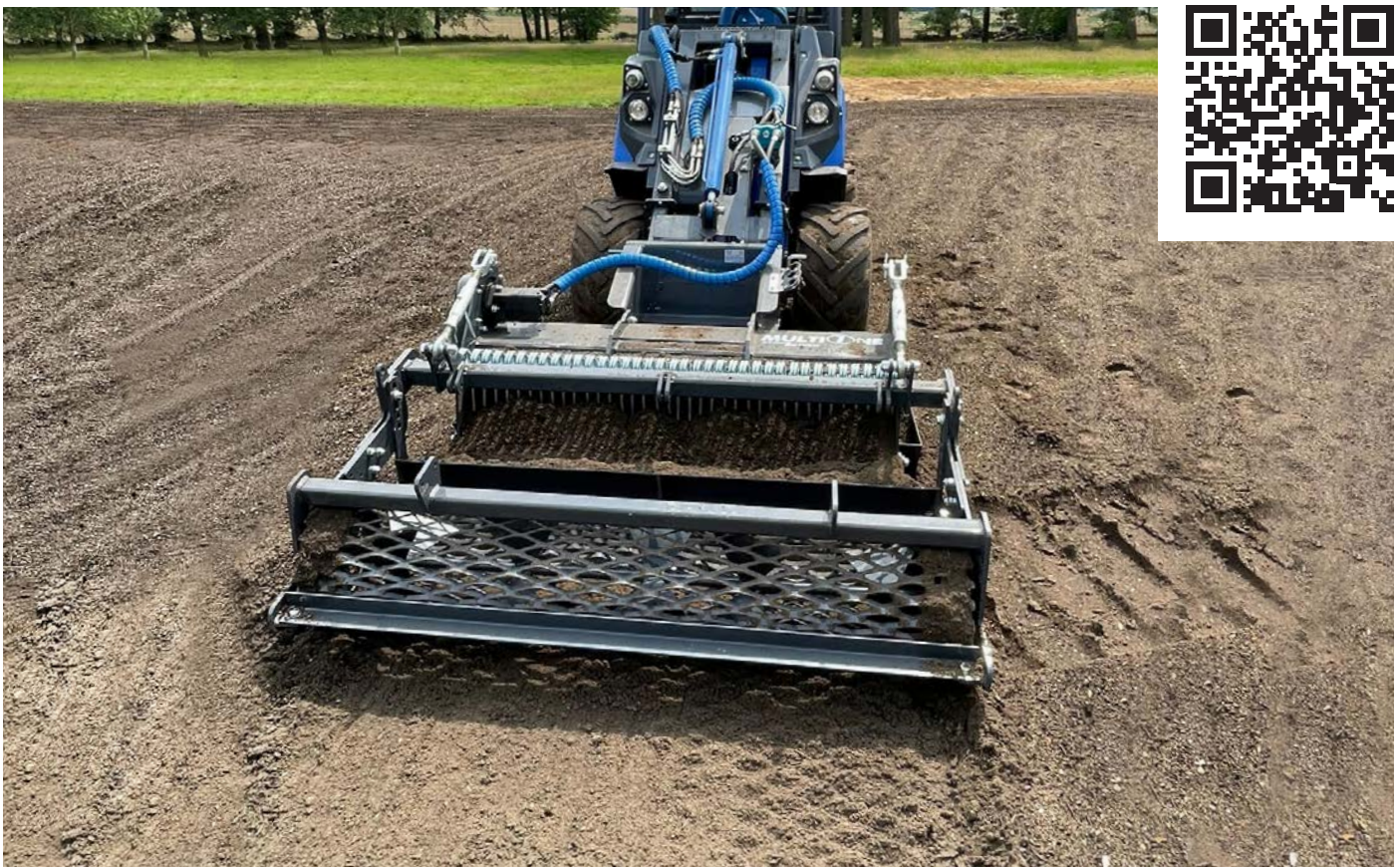
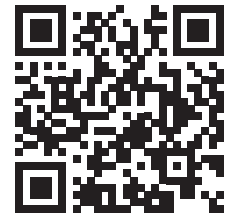

FEATURES & BENEFITS

- Professional, efficient stone burier
- Top grade finish in just one pass
- Can be equipped with seeding unit - ready lawn surface in a single pass

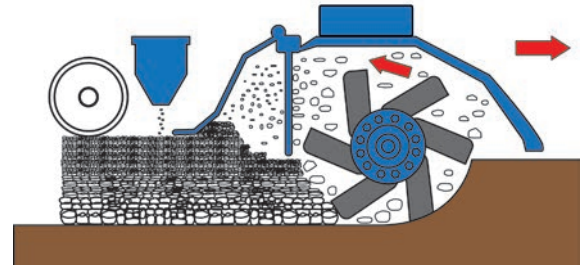

A professional hydraulic stone burier for preparation of lawn beds. The stone burier mills the soil, buries eventual stones and other objects up to 150 mm depth in a single pass, making a milled and tamped topsoil. Working depth is adjustable with the rear field roller. With the optional seeding unit you are able to make a ready lawn surface on one pass. Stone burier is most commonly used when the topsoil needs to be milled thoroughly.

Note: the floating boom valve on the machine is suggested.

Model	Working width	Working depth	Blades	Weight	Code
114 w/roller	114 cm (44.9 in)	0 - 15 cm (0- 6 in)	36	298 kg (657 lbs)	C890523
132 w/roller	132 cm (52 in)	0 - 15 cm (0- 6 in)	42	335 kg (739 lbs)	C890524
150 w/roller	150 cm (59 in)	0 - 15 cm (0- 6 in)	48	380 kg (838 lbs)	C890525
Options					
Seeding unit for stoneburier 114				70 kg (154 lbs)	C890529
Seeding unit for stoneburier 132				76 kg (167 lbs)	C890530
Seeding unit for stoneburier 150				90 kg (198 lbs)	C890531

Compatibility	1.1	2.3	4.2	5.2	5.3	6.3	7.2	8.4	8.5	11.6	11.9	EZ5	EZ7 EZ8
Model													
114 w/roller	Very compatible	Compatible	Compatible	Compatible	Compatible	Compatible	Compatible	Compatible	Compatible	Compatible	Compatible	Not compatible	Not compatible
132 w/roller	Very compatible	Compatible	Compatible	Compatible	Compatible	Compatible	Compatible	Compatible	Compatible	Compatible	Compatible	Not compatible	Not compatible
150 w/roller	Very compatible	Compatible	Compatible	Compatible	Compatible	Compatible	Compatible	Compatible	Compatible	Compatible	Compatible	Not compatible	Not compatible

Very compatible Compatible Not compatible



POWER PLOW

<http://tiny.cc/powerplow>



FEATURES & BENEFITS

- The corkscrew action of the blades pulls the plow through the ground
- The soil is discharged on the right hand side
- The horizontal digging action causes little or no hardpan

The MultiOne power plow can effortlessly dig into all types of soil, even hardened, rock-filled dirt that has never been broken. The rotary plow works well in areas with existing sod. It chops and buries the grass and roots and does not tangle easily.

This rotary plow is a powerful and effective method of preparing your soil for planting, and can work effectively in tight working areas, such as next to sidewalks, curbs, and other buildings. The power plow sticks out of the right side of the machine.

The blades once worn out are replaceable.



Model	Max Working Depth	Max Working Width	Weight	Code
Power Plow	25 cm (9.8 in)	35 cm (13.8 in)	93 kg (205 lbs)	C891241

Compatibility	1.1	2.3	4.2	5.2	5.3	6.3	7.2	8.4	8.5	11.6	11.9	EZ5	EZ7 EZ8
	Very compatible							Compatible			Not compatible		



POWER AUGER FOR TREE PLANTING

<http://tiny.cc/augertree>



FEATURES & BENEFITS

- Specifically designed for tree planting
- Two cutting head available

The powerful hydraulic auger is available with two cutting head diameters, specifically designed for tree planting. The special cutting head creates the hole without compacting the internal hole surface, allowing the tree to easily take root. It's the ideal attachment for work in nurseries, for the landscaping and for reforestation works. The cutting heads are equipped with replaceable teeth.



Model	Max Torque	Diameter	Weight	Code
Power auger for tree plating, drive unit, auger T3 (C890811 or C890812 required)	400 kgm	/	150 kg (331 lbs)	C890832
Cutting head 80		80 cm (31.5 in)	/	C890811
Cutting head 100		100 cm (39.4 in)	/	C890812

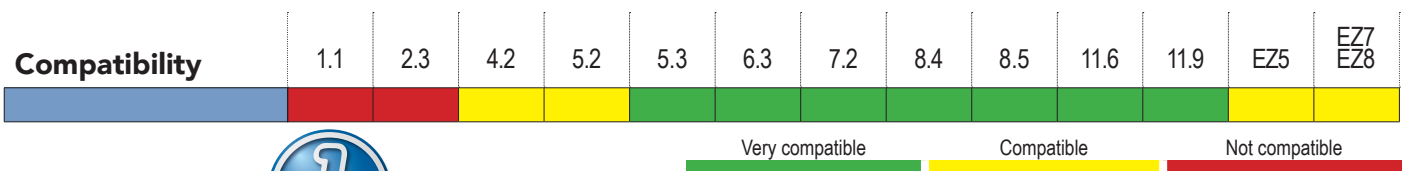

SWING STUMP GRINDER

<http://tiny.cc/swingstumpgrinder>

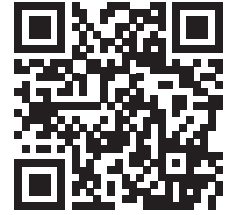

FEATURES & BENEFITS

- Excellent visibility of the cutting area
- Cuts large stumps without repositioning
- Replaceable teeth
- Equipped with a rubber cover – prevents wood waste from flying on the around.

The hydraulically powered stump grinder is a necessary tool for landscaping and forestry works. This unit hydraulically sweeps side to side effectively grinding the stump as deeply under ground as needed. It is equipped with a hydraulic oscillation system that moves the disc to the right and left to mill large logs.

The stump grinder is safely controlled from MultiOne's operator's seat. The solid steel cutter wheel and heavy duty replaceable teeth assure long lasting cutting performance. The stump grinder is also equipped with mechanical support legs which lift it off the ground for storage.

ACI ATTACHMENT CONTROL INTERFACE



Model	Swing angle	Teeth	Weight	Code
Swing Stump Grinder	±40°	18	107 kg (236 lbs)	C890517

Compatibility	1.1	2.3	4.2	5.2	5.3	6.3	7.2	8.4	8.5	11.6	11.9	EZ5	EZ7 EZ8
					Very compatible				Compatible			Not compatible	



STUMP GRINDER

<http://tiny.cc/stumpgrinder>



FEATURES & BENEFITS

- Cuts large stumps quickly
- Carbide-Tipped Teeth
- Excellent visibility of the cutting area
- Replaceable teeth
- Equipped with a rubber cover – prevents wood waste from flying on the around.

Designed for maximum operating capability, the stump grinder mounts directly to the front of a MultiOne machine for easy maneuvering in tight areas and positioning exactly where grinding action is needed. Mounted at a 90-degree angle to the operator, the stump grinder offers increased visibility to the cutting area, giving the operator the same wide view as with any pull-behind grinder.

The stump grinder is the ideal attachment for landscaping contractors, homeowners with acreage, campus facilities, municipalities, and rental contractors.

Stumps are eliminated even more quickly when used with machines equipped with high hydraulic flow rate.

The solid steel cutter wheel and replaceable carbide-tipped teeth efficiently rip through hard wood, providing long life and uptime protection for the attachment.

Model	Teeth	Weight	Code
Stump Grinder	24	165 kg (364 lbs)	C890516

Compatibility	1.1	2.3	4.2	5.2	5.3	6.3	7.2	8.4	8.5	11.6	11.9	EZ5	EZ7 EZ8
	Very compatible	Compatible	Compatible	Compatible	Compatible	Compatible	Compatible	Compatible	Compatible	Compatible	Compatible	Not compatible	Not compatible



FORESTRY MULCHER

<http://tiny.cc/forestrymulcher>



FEATURES & BENEFITS

- Heavy-duty soil conditioner - crush smaller roots, tree stumps and branches as well as ice and hard compact ground
- Carbide cutting teeth

The MultiOne forestry mulcher shows its versatility crushing forest residue, clearing land for site development, maintaining gravel roads, crushing ice, removing small roots and tree stumps as well.

Hydraulic motor is directly connected to eliminate transmission maintenance.

The rotor is equipped with replaceable and cost effective carbide cutting teeth

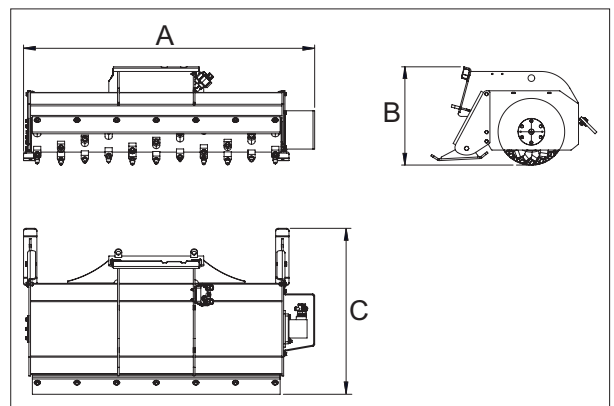

Dimensions (cm/in)		
A	B	C
175 / 69	59 / 23	100 / 39

Model	Width	Cutting Teeth	Rotor Width	Rotor Diameter	Weight	Code
Forestry Mulcher 150	175 cm (68.9 in)	66	150 cm (59 in)	40 cm (15.7 in)	390 kg (860 lbs)	C890970

Compatibility	1.1	2.3	4.2	5.2	5.3	6.3	7.2	8.4	8.5	11.6	11.9	EZ5	EZ7 EZ8
	Very compatible							Compatible			Not compatible		



BRANCH CUTTER

<http://tiny.cc/branchcutter>

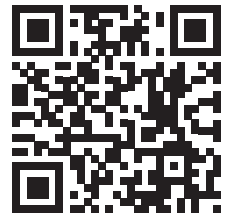
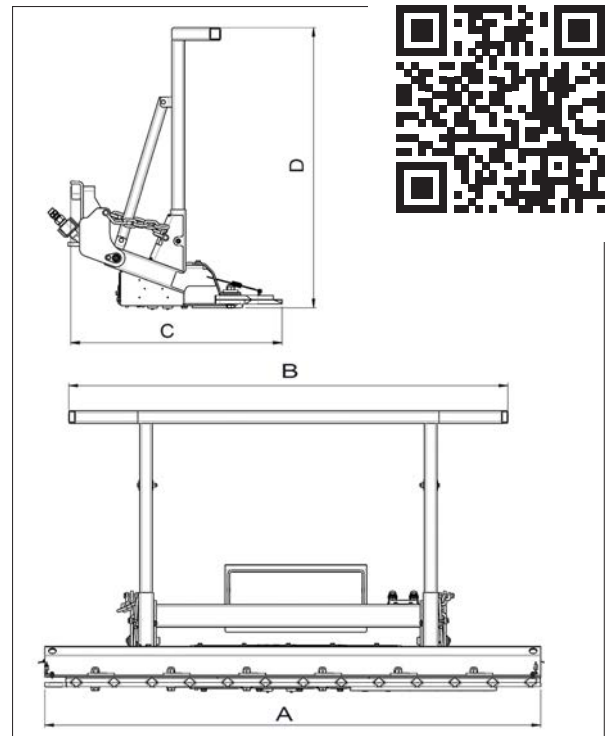

Dimensions (cm/in)				
Model	A	B	C	D
50-150	150 / 59	175 / 69	78 / 31	110 / 43
100-150	166 / 65	175 / 69	84 / 33	110 / 43
100-180	196 / 77	175 / 69	84 / 33	110 / 43

FEATURES & BENEFITS

- Pruning branches and shrubs from 50 mm to 100 mm diameter
- Compact design
- Heavy Duty Frame
- Upper bar

The new branch cutter it's the ideal choice to improve both green and forest maintenance.

It is a robust equipment, suitable for pruning branches and shrubs from 50 mm up to 100 mm diameter with a clean and precise cut without tearing plants. Its compact design guarantees easy handling and usability even in areas with dense vegetation. Best suited for uncultivated rough terrain and heavy overgrown weed fields. The branch cutter is designed with double blade system, the lower blade is fixed while the upper one is hydraulically operated. MultiOne branch cutter is top range in terms of design, reliability, speed and cut quality. The bar is made with Hardox blades, which are very strong and resistant to stress.

Tipping frame prevents damages to branch cutter and machine, from oversized shrubberies and bushes. It is also equipped with an upper bar that protects the machine from falling small trees and shrubs.

Model	Cutting Width	Max. cutting diameter	Weight	Code
Branch cutter BT50-150	150 cm (59 in)	5 cm (2 in)	200 kg (441 lbs)	C890953
Branch cutter BT100-150	160 cm (63 in)	10 cm (4 in)	254 kg (560 lbs)	C890954
Branch cutter BT100-180	190 cm (75 in)	10 cm (4 in)	272 kg (600 lbs)	C890952

Compatibility	1.1	2.3	4.2	5.2	5.3	6.3	7.2	8.4	8.5	11.6	11.9	EZ5	EZ7 EZ8
Model													
BT50-150	Not compatible	Not compatible	Not compatible	Very compatible	Compatible	Compatible	Compatible	Compatible	Compatible	Compatible	Compatible	Not compatible	Not compatible
BT100-150	Not compatible	Not compatible	Not compatible	Very compatible	Compatible	Compatible	Compatible	Compatible	Compatible	Compatible	Compatible	Not compatible	Not compatible
BT100-180	Not compatible	Not compatible	Not compatible	Very compatible	Compatible	Compatible	Compatible	Compatible	Compatible	Compatible	Compatible	Not compatible	Not compatible

Very compatible Compatible Not compatible



TIMBER GRAB

<http://tiny.cc/timbergrab>

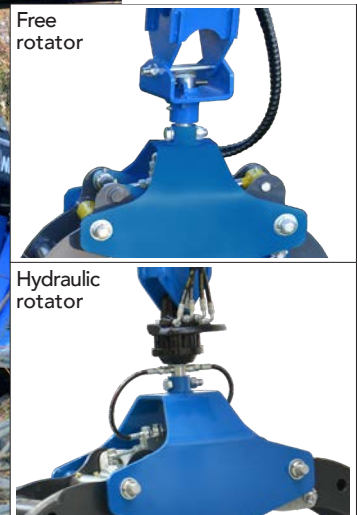

FEATURES & BENEFITS

- Available with hydraulic rotator or as freely rotating version
- Versatile attachment for transporting and loading of timber, branches, etc.
- Load holding valve
- Rotating grab allows transporting also lengthwise - makes it possible to pass through narrow places with long logs and facilitates work in dense forest

Timber grab is an attachment that allows you to grab tree trunks, branches, wood waste, kerb stones etc. and transport them both lengthwise and crosswise. In this way it is possible to pass through narrow places also with long logs and enables loading on trailer or on a pile in any direction. It is equipped with an upper tooth bar to move the branches and a lower one that avoids the trunk swinging during transport. Timber grab is available either with a hydraulic rotator or as freely rotating version.

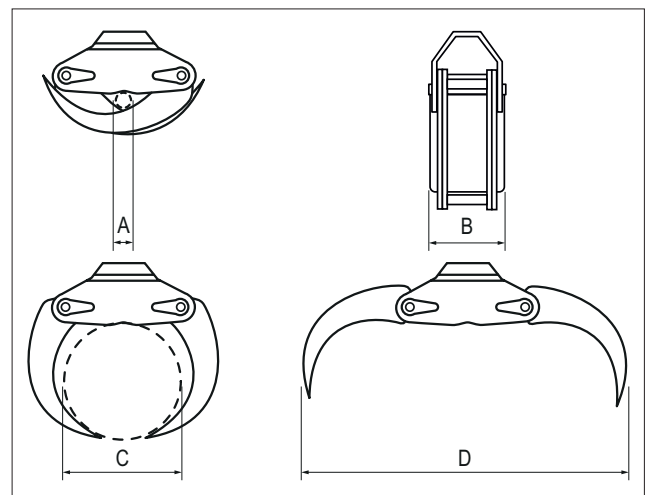

Dimensions (cm/in)				
Model	A	B	C	D
120	8 / 3.1	36 / 14	45 / 17.7	120 / 47

Model	Lifting Capacity*	Max Opening Length	Weight	Code
Timber grab 120	1500 kg (3037 lbs)	120 cm (47 in)	207 kg (456 lbs)	C890584
Timber grab 120 w/rotator	1500 kg (3037 lbs)	120 cm (47 in)	192 kg (423 lbs)	C890586
Pull bars (set of 2)	/	/	4 kg (9 lbs)	C890587

(*) verify the lifting capacity of the machine

Compatibility	1.1	2.3	4.2	5.2	5.3	6.3	7.2	8.4	8.5	11.6	11.9	EZ5	EZ7 EZ8
Model													
Timber grab 120													
Timber grab 120 w/rotator													

Very compatible Compatible Not compatible



WINCH

<http://tiny.cc/m1winch>

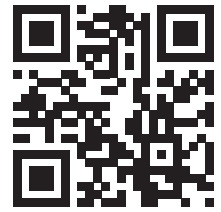

FEATURES & BENEFITS

- Powerful and compact hydraulic winch
- Equipped 25 m (82 ft) of wire rope
- The operator can safely and easily control it from the operator's seat

The MultiOne hydraulic winch enables towing of all kinds of objects (e.g. logs, poles, boats) from places where you cannot drive with the machine.

The winch is equipped with a safety net, 25 m (82 ft) of wire rope and a towing hitch. It is powered by a powerful hydraulic motor and mounts on MultiOne's quick attach plate. Use of the winch is simple, one person can easily handle it. Auxiliary hydraulics control lever (or switch) is switched to continuous flow (locking position) from the operator's seat, which releases the wire drum so that the wire can be pulled out by hand. When the wire is attached to the desired object, operator returns to machine's seat and turns the auxiliary hydraulics lever (or switch) to opposite direction and the winch begins to reel in the rope.

The winch stops as soon as the auxiliary hydraulics control lever (or switch) is released.



Model	Cable Length	Pulling Force	Max reeling speed	Weight	Code
Winch	25 m (82 ft)	1000 kg (2204 lbs)	2,5 m/s (8.2 ft/s)	95 kg (210 lbs)	C891210

Compatibility	1.1	2.3	4.2	5.2	5.3	6.3	7.2	8.4	8.5	11.6	11.9	EZ5	EZ7 EZ8
	Very compatible				Compatible				Not compatible				



TREE SHEAR

<http://tiny.cc/treeshear>



FEATURES & BENEFITS

- Powerful and safe tree shear
- Clean and precise cuts
- Excellent tool for forest thinning, tree clearance etc.
- Thanks to the strong grapple the tree is easy to take away
- Available with hydraulic or fixed blade



The MultiOne tree shear is an efficient and useful tree cutter, intended for forest thinning, tree clearance and similar jobs where smaller trees need to be cut. The strong grapple grants a firm grip of the tree trunk and the cutting blade cuts the trunk. The tree is then easy and fast to move away with MultiOne machine.

Two models are available: with fixed blade for trunks up to 10 cm diameter and with hydraulic blade for trunks up to 15 cm diameter. Through the reach of the MultiOne's boom, this unit can also be used to prune branches, and clear scrub growth in places difficult to reach.

Model	Ø Max Limb	Max Opening	Weight	Code
Hydraulic Blade	15 cm (5.9 in)	50 cm (19.7 in)	380 kg (838 lbs)	C891071
Fixed Blade	10 cm (3.9 in)	60 cm (23.6 in)	200 kg (441 lbs)	C891070

Compatibility	1.1	2.3	4.2	5.2	5.3	6.3	7.2	8.4	8.5	11.6	11.9	EZ5	EZ7 EZ8
Model													
Hydraulic Blade													
Fixed Blade													

Very compatible
 Compatible
 Not compatible



LOG GRAPPLE

<http://tiny.cc/loggrab>



FEATURES & BENEFITS

- Useful attachment for fencing and forest work
- Independent arms operated by two cylinders
- Strong log grab, also for more professional and frequent log handling
- Heavy duty design allows grabbing of bigger tree trunks as well

The heavy duty MultiOne log grapple is a very powerful and flexible tool used to securely grab, lift, and transport harvested logs. The hydraulically powered grapple arms firmly grip the logs, securing them to the lower forks. The design of the grapple accommodates small logs to large tree trunks. Thanks to the high lifting capacity of MultiOne machines, it is possible to perform forest works and to load trucks or trailers, even in inaccessible or hard-to-reach areas.



Model	Width	Teeth length	Opening Angle	Weight	Code
Log grapple	100 cm (39.4 in)	101 cm (39.8 in)	68°	120 kg (265 lbs)	C890580

Compatibility	1.1	2.3	4.2	5.2	5.3	6.3	7.2	8.4	8.5	11.6	11.9	EZ5	EZ7 EZ8



INDUSTRIAL LOG GRAPPLE

<http://tiny.cc/industrialloggrapple>

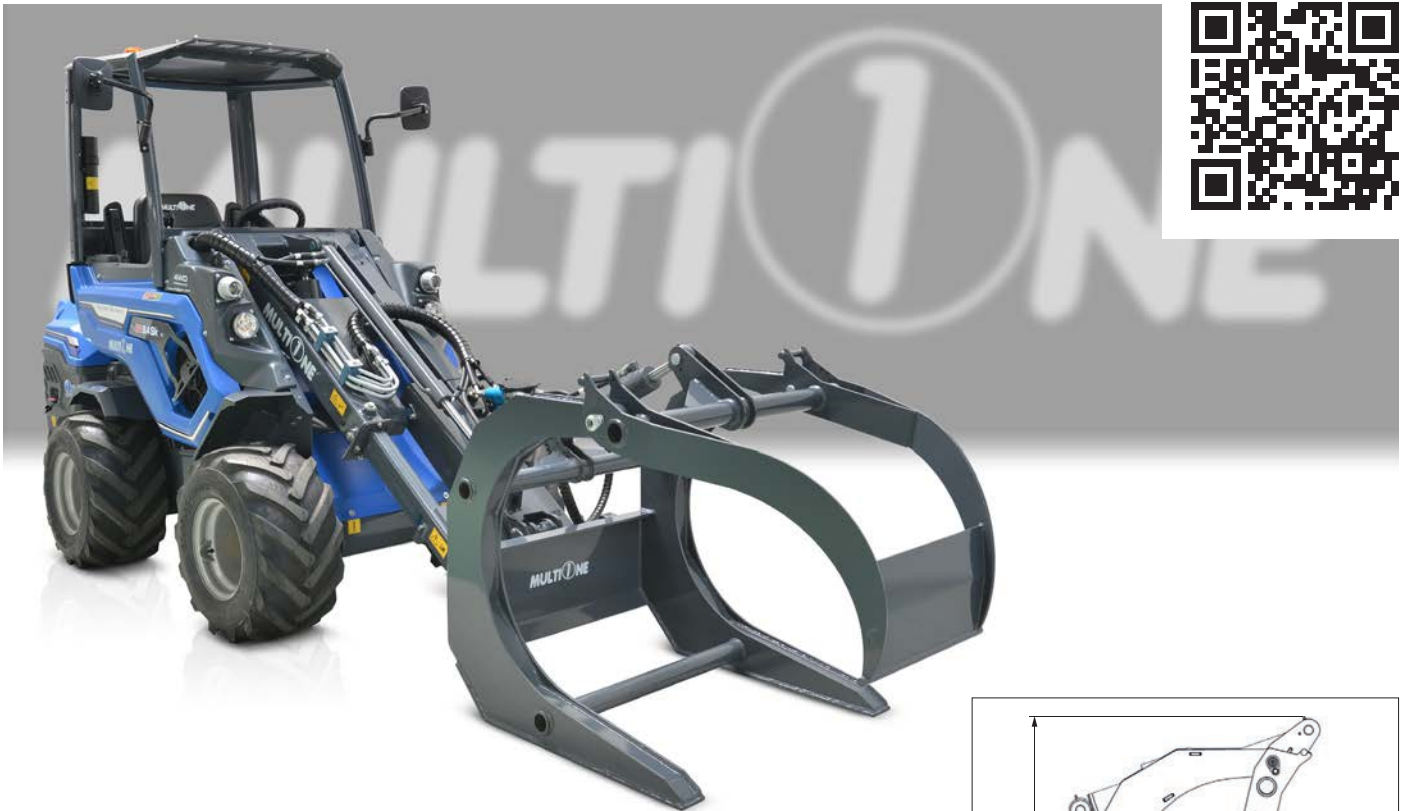
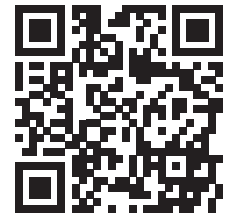

FEATURES & BENEFITS

- Strong hydraulic curved jaw
- Wide jaw opening
- Heavy duty design allows grabbing of bigger tree trunks
- Ideal for grabbing and transporting logs but also big stones

Multione industrial log grapple is intended for lifting and transporting logs, firewood branches or also big stones...anything that fits! The grapple is designed to ensure steady grabbing of logs of different diameters. It has a powerful hydraulic upper jaw, which also ensures secure holding of long logs. In addition, this attachment can hold single or multiple logs with ease. This is due to the unique optimally curved jaw which allows the logs to roll right up the inner surface of the beak. It is ideal for land clearing and logging operations where time and money are crucial, and space is limited. Strong and durable design guarantees long service life of the attachment.

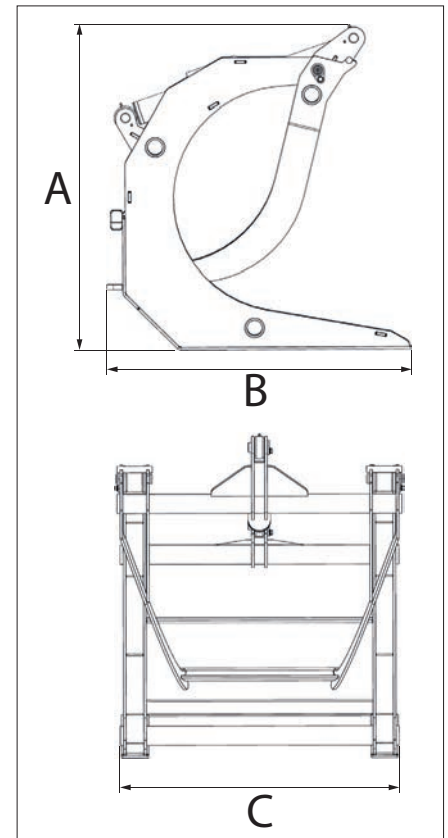

Dimensions (cm/in)		
A	B	C
100 / 39	95 / 37	90 / 35

Model	Max Load*	Log diameter (min÷max)	Weight	Code
Industrial log grapple	2000 kg (4400 lbs)	30÷70 cm (12÷27 in)	180 kg (397 lbs)	C891090

(* verify the lifting capacity of the machine)

Compatibility	1.1	2.3	4.2	5.2	5.3	6.3	7.2	8.4	8.5	11.6	11.9	EZ5	EZ7 EZ8
	Very compatible				Compatible				Not compatible				



LOG SPLITTER

<http://tiny.cc/logsplitter>



FEATURES & BENEFITS

- **Powerful (7 ton) and safe logs splitter**
- **Max. log diameter 400 mm**

The hydraulically powered MultiOne log splitter allows to safely and quickly split cut logs into firewood. The wedge, driven by a powerful hydraulic cylinder, allows to split the log in two or in four pieces with the optional tool. The wedge travel is adjustable to avoid downtime. It is equipped with a large adjustable support table with three positions: high 83 cm (32.7 in), medium 59 cm (23.2 in) and low 35 cm (13.8 in). With a power of 7 ton it is able to split logs up to 40 cm diameter. There are two control levers which have to be activated with both hands for increased safety. It is equipped with wheels for transport and it can also be moved manually using the handle.



Model	Power	Wedge Stroke	Max log diameter	Max log height	Weight	Code
Log splitter	7 ton	55 cm (21.6 in)	40 cm (15.7 in)	100 cm (39.4 in)	110 kg (242 lbs)	C890570

Compatibility	1.1	2.3	4.2	5.2	5.3	6.3	7.2	8.4	8.5	11.6	11.9	EZ5	EZ7 EZ8

Very compatible
 Compatible
 Not compatible



DUMPER

<http://tiny.cc/dumper2>



FEATURES & BENEFITS

- Cost effective
- High capacity

The MultiOne dumper is a very useful tool used to collect, transport, store, and empty waste. There are two sizes, a 200 l (7 cu ft) unit, and the larger 400 l (14 cu ft). Each of these units can stand on its own when detached from the MultiOne, and easily dumped by the machine when full. The smaller model can be easily unloaded by lifting the machine boom, while the larger model is equipped with a front side that can be open with a lever.



Model	Capacity*	Width	Length	Height	Weight	Code
200	200 l (7 ft ³)	95 cm (37.4 in)	90 cm (35.4 in)	51 cm (20 in)	60 kg (132 lbs)	C890280
400	400 l (14 ft ³)	97,5 cm (38.4 in)	132 cm (52 in)	83 cm (32.7 in)	97 kg (214 lbs)	C890285

(* verify the lifting capacity of the machine)

Compatibility	1.1	2.3	4.2	5.2	5.3	6.3	7.2	8.4	8.5	11.6	11.9	EZ5	EZ7 EZ8
Model													
200													
400													

Very compatible
 Compatible
 Not compatible



HYDRAULIC BIO SHREDDER

<http://tiny.cc/bio-shredder>



FEATURES & BENEFITS

- Compact dimensions
- Excellent tool for chipping branches and small tree trunks
- Manual feeding and discharge chute rotation
- Equipped with safety stop system
- Foldable for easy transport



The hydraulically powered chipper/shredder is a powerful tool for quickly reducing a pile of brushes, garden wastes, and tree limbs to reusable shredded mulch. Combined with the MultiOne, this chipper/shredder can work in areas not reachable with a traditional towed chipper.

The machine incorporates a feed roller that pulls the branches up to 90 mm (3.5 in) diameter into the chipper section in a controlled, safe speed. The chips are then processed by the shredder section, reducing the wood chips to mulch. The operator remains safely out of the way during the chipping/shredding process.

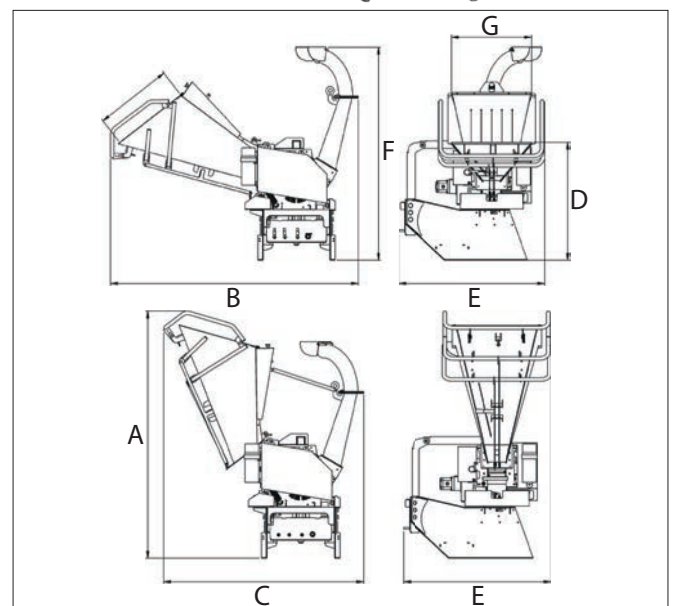

		Dimensions						
		A	B	C	D	E	F	G
cm		210	222	170	101	126	182	70
in		83	88	67	40	50	72	28

Model	Max timber diameter	Weight	Code
Hydraulic bio shredder	9 cm (3.5 in)	335 kg (740 lbs)	C890731

Compatibility	1.1	2.3	4.2	5.2	5.3	6.3	7.2	8.4	8.5	11.6	11.9	EZ5	EZ7 EZ8
	Very compatible	Compatible	Compatible	Compatible	Compatible	Compatible	Compatible	Compatible	Compatible	Compatible	Compatible	Not compatible	Not compatible



ALUMINIUM RAMPS



FEATURES & BENEFITS

- **Light and Durable**

The sturdy aluminium ramps are durable and lightweight for easy handling. These ramps are designed with deep ridge treads for better traction that enables safe and efficient loading and unloading of the MultiOne from trucks and trailers.

NOTE: When ordering, please specify the machine model, weight, and wheelbase.

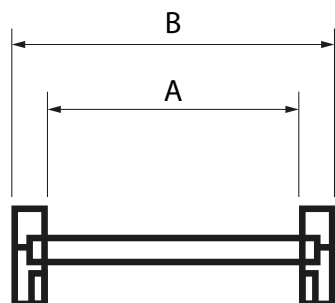

Model	Loading capacity per pair	
	Machine wheelbase 100 cm (39 in)	Machine wheelbase 150 cm (59 in)
250	2500 kg (5511 lbs)	3800 kg (8377 lbs)
300	1900 kg (4189 lbs)	2500 kg (5511 lbs)
350	2000 kg (4409 lbs)	2500 kg (5511 lbs)
400	2290 kg (5048 lbs)	2750 kg (6062 lbs)
450	1070 kg (2359 lbs)	1250 kg (2756 lbs)
500	2575 kg (5677 lbs)	2945 kg (6493 lbs)

Model	Length	Internal Width (A)	External Width (B)	Weight	Code
250	250 cm (98.4 in)	34 cm (13.4 in)	40 cm (15.7 in)	43 kg (95 lbs)	C890790
300	300 cm (118 in)	34 cm (13.4 in)	40 cm (15.7 in)	52 kg (115 lbs)	C890791
350	350 cm (138 in)	34 cm (13.4 in)	40 cm (15.7 in)	62 kg (137 lbs)	C890792
400	400 cm (157.5 in)	34 cm (13.4 in)	40 cm (15.7 in)	56 kg (123 lbs)	C890793
450	450 cm (177.2 in)	34 cm (13.4 in)	40 cm (15.7 in)	78 kg (172 lbs)	C890794
500	500 cm (197 in)	34 cm (13.4 in)	40 cm (15.7 in)	86 kg (190 lbs)	C890795

SIDE SHIFT ADAPTER

<http://tiny.cc/sideshiftadapter>

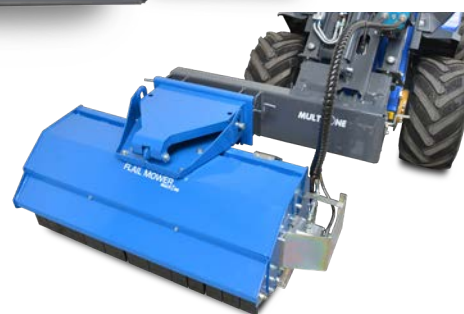

FEATURES & BENEFITS

- Makes it possible to mount the attachment 60 cm (24 in) shifted to the right from the centerline
- Mounts between the attachment and the quick attach plate of the loader

The MultiOne side shift adapter is a simple and strong accessory that is mounted between the attachment and the machine quick attach plate. In this way it is possible to mount the attachment shifted to the right by 60 cm (24 in). It is very useful when, for example, you have to cut grass with a flail mower along the edge of a road.

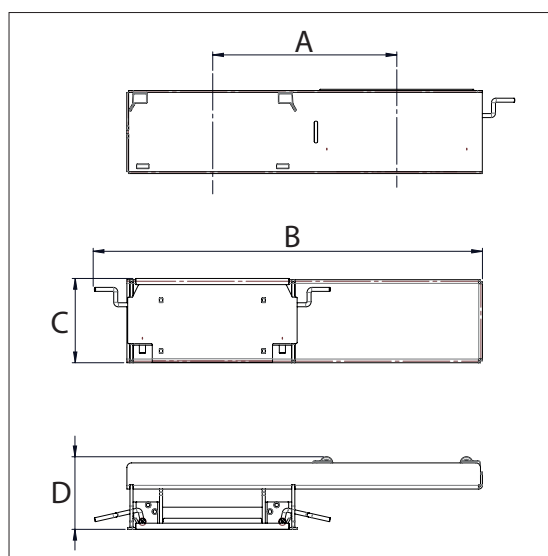

		Dimensions			
		A	B	C	D
cm		60	127	27	24
in		23.6	49.8	10.8	9.3

Model	Side Shift	Max Load*	Weight	Code
Side Shift Adapter	60 cm (23.6 in)	1000 kg (2204 lbs)	60 kg (133 lbs)	C890910

(* verify the lifting capacity of the machine)

Compatibility	1.1	2.3	4.2	5.2	5.3	6.3	7.2	8.4	8.5	11.6	11.9	EZ5	EZ7 EZ8

Very compatible
 Compatible
 Not compatible



TILT ADAPTER

<http://tiny.cc/tiltadapter>



FEATURES & BENEFITS

- Makes it possible to tilt the attachment sideways and e.g. grade the ground with a bucket or leveller, or load pallets on uneven ground with pallet fork
- Mounts between the attachment and the quick attach plate of the loader

MultiOne tilt adapter is mounted between the attachment and the loader's attachment coupling plate. Thanks to this the attachment can be tilted sideways, and makes it possible to:

- Make different forms to the ground with a bucket or leveller
- Keep pallet fork level when you are driving on surfaces with gradient
- Load pallets that are on uneven ground
- Level ground on uneven surfaces

Tilt adapter with max. 14,5 degrees tilting in both directions. It is ideal for buckets, leveller and pallet forks – for jobs where tilting is a must but the tilting angle doesn't have to be big.

The tilt adapter is intended mainly for non hydraulically operated attachments, but with the optional second auxiliary hydraulics outlet in the front it is possible to mount also hydraulically driven attachments like a 4 in 1 bucket, pallet fork with hydraulic fork adjustment, grabbing tool, artificial turf attachment and rock drill at the same time.

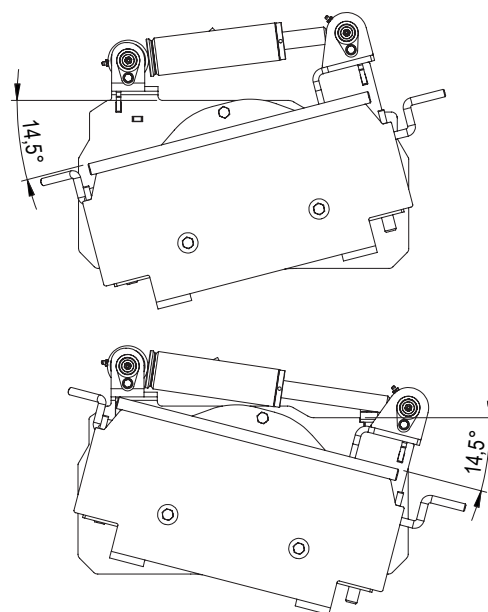

Model	Max tilt	Max Load*	Length	Weight	Code
Tilt adapter	+/- 14.5°	500 kg (1102 lbs)	14 cm (5.5 in)	52 kg (115 lbs)	C890190

(* verify the lifting capacity of the machine)

Compatibility	1.1	2.3	4.2	5.2	5.3	6.3	7.2	8.4	8.5	11.6	11.9	EZ5	EZ7 EZ8

Very compatible
 Compatible
 Not compatible



ATTACHMENT ROTATOR

<http://tiny.cc/attachmentrotator>



FEATURES & BENEFITS

- **360° rotation**
- **Mounts between the attachment and the quick attach plate of the loader**

The attachment rotator is designed for a 360°, smooth, continuous motion in both directions. The attachment rotator is commonly used in many jobs for inverting and dumping loads.

Like the tilt adapters, the attachment rotator mounts between the attachment and the loader's attachment coupling plate. It is equipped with a hydraulic motor and a slewing ring that allows the 360° rotation. Maximum load capacity is 1.200 kg. The rotator attachment coupling plate is 255 mm further away from the machine's attachment coupling plate.

The attachment rotator is intended mainly for non-hydraulically operated attachments, but with the optional second auxiliary hydraulics outlet on the loader it is possible to use with hydraulically driven attachments also like a 4 in 1 bucket, pallet fork with hydraulic fork adjustment, grabbing tool, etc.. at the same time.

Model	Max tilt	Max Load*	Weight	Code
Attachment rotator	360 °	1200 kg (2645 lbs)	73 kg (161 lbs)	C890960

(* verify the lifting capacity of the machine)

Compatibility	1.1	2.3	4.2	5.2	5.3	6.3	7.2	8.4	8.5	11.6	11.9	EZ5	EZ7 EZ8

Very compatible

Compatible

Not compatible



MULTI CONNECTOR ADAPTOR FOR MACHINES



Adaptor for machines, in order to connect standard flat face single lines connections. Suggested for attachments equipped with hydraulic cylinders, not with hydraulic motors. The adaptor has 3 lines to fulfill the connections with any kind of attachments.

Model												Code	
Multiconnector to single line quick coupling, 3 lines for machines												C880221	
Compatibility	1.1	2.3	4.2	5.2	5.3	6.3	7.2	8.4	8.5	11.6	11.9	EZ5	EZ7 EZ8
<div style="display: flex; justify-content: space-between; width: 100%;"> Very compatible Compatible Not compatible </div>													

ATTACHMENT COUPLING PLATE



This plate can be welded to attachments that do not have the MultiOne style of mounting plate, making all attachments usable on the MultiOne. NOTE: The following need to be checked before using this coupling plate (at customer charge):

- Applicable laws and safety requirements.
- Machine and hydraulic circuit interface.

Model												Code	
Attachment coupling plate (to be welded) for MultiOne - 6 mm thickness												C880233	
Attachment coupling plate (to be welded) for MultiOne - 12 mm thickness												C880236	
Compatibility	1.1	2.3	4.2	5.2	5.3	6.3	7.2	8.4	8.5	11.6	11.9	EZ5	EZ7 EZ8
<div style="display: flex; justify-content: space-between; width: 100%;"> Very compatible Compatible Not compatible </div>													

SKID-STEER ATTACHMENT ADAPTER PLATE

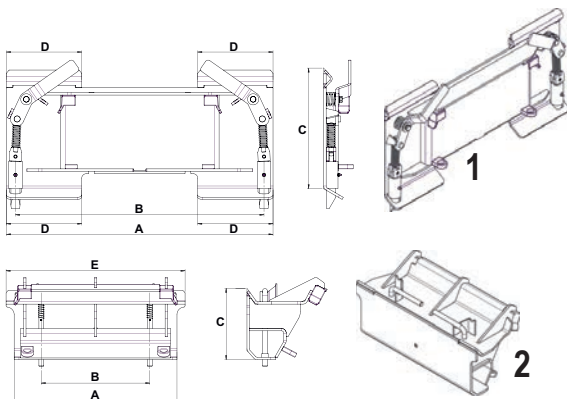

Coupling adapter suitable to mount skid steer attachments on MultiOne mini loader.

	Dimensions (mm/in)				
	A	B	C	D	E
Mod. 1	885 35	825 32.5	401 16	250 9.8	/
Mod. 2	543 21.4	362 14	238 9.4	/	597 23.5

Model		Weight										Code	
1 - MT skid steer attachment adapter plate		/										C890023	
2 - Mini skid steer attachment adapter plate		36 kg (79 lbs)										C880230	
Compatibility	1.1	2.3	4.2	5.2	5.3	6.3	7.2	8.4	8.5	11.6	11.9	EZ5	EZ7 EZ8
<div style="display: flex; justify-content: space-between; width: 100%;"> Very compatible Compatible Not compatible </div>													



ATTACHMENTS IN ALPHABETICAL ORDER

AERIAL WORK PLATFORM	115	MULTI CONNECTOR ADAPTOR FOR MACHINES	162
ALUMINIUM RAMPS	158	NEW GENERAL BUCKET	61
ARTICULATED SIDE ARM M1-30	129	NEW LIGHT MATERIAL BUCKET	66
ATTACHMENT COUPLING PLATE	162	OPTIONS FOR AUGER	95
ATTACHMENT ROTATOR	161	PALLET FORK	68
AUGER	94	PALLET FORK HYDRAULIC CLAMP	69
BALE FORK	80	PALLET FORK WITH SIDE SHIFT	73
BALE HANDLER	78	PIPE LAYER RIPPER	100
BIG BAG LIFTER	70	POWER AUGER FOR TREE PLANTING	145
BRANCH CUTTER	149	POWER HARROW	141
CEMENT MIXER	97	POWER PLOW	144
COLD PLANER	99	POWER RAKE	142
COMBO BUCKET	63	PUSH BROOM	87
CONCRETE MIXING BUCKET	98	RADIO CONTROLLED BACKHOE	93
CORE AERATOR	124	RIPPER	139
DEBRIS AND LEAF BLOWER	104	ROLLER	138
DEMOLITION GRAPPLE BUCKET	65	ROTARY SWEEPER	106
DOZER BLADE	89	ROTARY TILLER	140
DROP SPREADER	111	RUBBER SCRAPER	86
DUAL BLADE HEDGE TRIMMER	132	SALT AND SAND SPREADER	110
DUMPER	156	SCREENING BUCKET	92
FEED DISPENSER	84	SCREW FEED PUSHER	85
FLAIL MOWER	118	SICKLE BAR MOWER	126
FLAIL MOWER WITH SIDE SHIFT	117	SIDE BOOM WITH FLAIL MOWER DZ2	120
FORESTRY MULCHER	148	SIDE SHIFT ADAPTER	159
GENERAL BUCKET	60	SKID-STEER ATTACHMENT ADAPTER PLATE	162
GRADER	96	SNOW BLADE	107
GRAPPLE BUCKET	64	SNOW BLOWER	109
HAY BALE GRAPPLE	77	SNOW PLOW	108
HEAVY DUTY FLAIL MOWER	119	SOLAR PANEL WASHER	105
HEAVY DUTY SILAGE FORK	75	SPIKE AERATOR	123
HEDGE CUTTER	125	SPRAYER	130
HIGH PRESSURE WASHER	113	SQUARE BALE CLAMP	79
HIGH TIP BUCKET	67	STAKE INSTALLER	114
HIVE HANDLER	81	STONE BURIER	143
HORSE ARENA HARROW	82	STREET WASHER	116
HORSE STABLE PACKER	83	STRING SHOOT REMOVER	131
HYDRAULIC BIO SHREDDER	157	STUMP GRINDER	147
HYDRAULIC BREAKER	88	SWEEPER WITH COLLECTOR BOX	101
INDUSTRIAL LOG GRAPPLE	154	SWING STUMP GRINDER	146
INTER-ROW MOWER	133	TELESCOPIC SIDE ARM M1-15	128
JIB CRANE, ONE-PIECE OR TELESCOPIC	71	TILT ADAPTER	160
JOB SITE TOOLBOX	74	TIMBER GRAB	150
LANDSCAPE POT CLAMP	127	TORNADO LAWN MOWER	121
LAWN MOWER	122	TRAILER	112
LEAF VACUUM	102	TREE SHAKER WITH COLLECTOR	134
LEVELLER	137	TREE SHEAR	152
LEVELLING BUCKET	62	TRENCHER	90
LIFTING TROLLEY	72	VINEYARD SPRAYER	135
LOG GRAPPLE	153	VINEYARD TOOL CARRIER	136
LOG SPLITTER	155	WEED BRUSH	103
MANURE FORK	76	WINCH	151
MINI DIGGER	91		

MULTI ONE

WHATEVER YOU NEED
MULTIONE CAN DO IT



DEPL/PRODUCTS-HANDBOOK R.250-EN

WWW.MULTIONE.COM

MultiOne srl
via Palù, 6/8
36040 Grumolo delle Abbadesse
Vicenza - Italy
info@multione-csf.com

The information and images herein contained are provided for illustrative purposes only and are not binding on MultiOne, who reserves the right to change them at any time without notice. 2025 MultiOne srl. All rights reserved.